

DeskArtes

3Data Expert 16.0

Tutorial 3 - Separating Shells
for different material and color definitions

First Edition

“3Data Expert 16.0: Tutorial 3 - Separating Shells”.

February 2026

Copyright

© 2026 DESKARTES. All rights reserved.

DESKARTES reserves the right to revise this publication and to make changes from time to time without the obligation to notify any person of such revisions and changes.

Trade Marks

The DESKARTES name and the logo are trademarks of DESKARTES Oy. Other brand and product names are trademarks and registered trademarks of their respective owners.

Contact Address

DESKARTES OY
Takomotie 8
FIN-00380 Helsinki
Finland

<https://www.deskartes.com>

Table of Contents

FOREWORD.....	4
CHAPTER 1 – PREPARING FOR SHELL SEPARATION	6
<i>Input cellphone.3de</i>	6
CHAPTER 2 – SIMPLIFYING WITH THE CLEANING SURFACES COMMAND.....	9
CHAPTER 3 – USING OFFSET TO SHELL COMMAND.....	10
CHAPTER 4 – USING EXTRUDE TO SHELL COMMAND	13
CHAPTER 5 – USING THE FILL TO SHELL COMMAND.....	15
<i>Outputting separate STL files</i>	16
CHAPTER 6 – USING CUT TOOL TO SEPARATE SHELLS.....	19
<i>Separating the largest fixture</i>	19
<i>Renaming shells and outputting STL files</i>	25
<i>Emulating material properties with colors</i>	26
<i>More cutting planes</i>	26
<i>Using Hole Tool to separate small flat surface areas</i>	27
CHAPTER 7 – USING EXTRUDE TO SEPARATE SHELLS.....	29
<i>Creating surfaces with Edit Triangles command</i>	29
<i>Using Extrude from Surfaces command</i>	30
<i>Copying Extruded surfaces to original shell</i>	32
CHAPTER 8 – USING OFFSET TO SEPARATE SHELLS	33
<i>Separating the sketched surface</i>	35
<i>Using Offset command</i>	35
<i>Selecting multiple surfaces for Offset or Extrude</i>	40
CONCLUSIONS	43

Foreword

The *3Data Expert 16.0: Tutorial 3 - Separating Shells* document provides a few simple examples on how to separate areas in a shell into separate shells for different material or color definitions. The separated shells can be used to produce 3D printed parts with multiple materials (= different shore values) or with different material colors in different areas.

First, this document describes the use of special and easy-to-use *Modify Faceted > Separate to Shell* commands for separating model surface areas into new shells. There are three different separation commands available: *Offset to Shell*, *Extrude to Shell*, and *Fill to Shell* commands. Accompanied with the *Fix Model > Clean Surfaces* command, shell separation is possible with just a few mouse clicks. The time requirement for these examples (Chapters 1 to 5) is about 10 minutes.

The document also describes the use of normal *Cut Tool* and *Hole Tool* commands for separating shells by cutting the model. *Extrude from surfaces* and *Offset* commands are used to generate solid shells from selected surface areas. The use of *Triangle Edit* and *Sketch Edge Line* commands to define new surfaces areas for shell separation are also described. The time requirement for these examples is about 20 minutes.

If you are not yet familiar with 3Data Expert, we recommend that you go through the *3Data Expert Quick Start Guide* (available through *Help > Tutorial Documents* menu) to learn basic visualization and selection commands before going through this document. Also, the *Split* command can be used for separating shells, as explained in the Quick Start Guide.

The full tutorial set for 3Data Expert 16.0 contains several documents which cover different aspects of model repair, coloring and print preparation. The tutorials are available in the software distribution package through the *Help > Tutorial Documents* menu:

- *3Data Expert 16.0: Quick Start Guide* gives a short introduction to model repair and splitting for 3D Printing with 3Data Expert. Estimated completion time 15 minutes.
- *3Data Expert 16.0: Tutorial 1 – Working with 3D Models* introduces basic viewing, measuring, automatic repair, split, connect, hollow, offset, 3D Text, Boolean, cut, reduce, 3D nesting, surface triangulation and other model manipulation functions available for STL files. Estimated completion time is 3 hours.
- *3Data Expert 16.0: Tutorial 2 – Working with Colors* introduces basic automatic repair and coloring for 3D Color Printer users. For 3Data Expert Base, Lite and Color modules. Estimated completion time is 1 hour.
- *3Data Expert 16.0: Tutorial 3 - Separating Shells* describes the use of Shell Separation commands in 3Data Expert. These commands enable

3Data Expert 16.0: Tutorial 3 - Separating Shells

separating a part into several shells for different material (shore value) or color definitions in a single part. For 3Data Expert Base only. Estimated completion time is 30 minutes.

- *3Data Expert 16.0: Tutorial 4 – Generating Supports for AM* explains the use of new Generic Supports command and Sand Supports command. The support generator can be used to generate supports for DLP, metal, stereolithography and sand-based processes. Adding extra connectors to prevent parts from warping and bending during the build is explained. Also, new slicing, slice preview and slice filling is demonstrated. Estimated completion time 1 hour.
- *3Data Expert 16.0: STL and VRML repair examples* document includes more advanced model repair operations with 3Data Expert. Applies to the 3Data Expert Base module and mostly to the Lite and Dimensions modules. Estimated completion time with 3Data Expert Base is 2 hours.

The tutorial documents and the geometry files for the tutorial examples are found in the *Tutorials* folder and its sub-folders (*GeomFiles*, *Tutorial 1*, *Tutorial 2*, etc.) in the 3Data Expert installation folder.

This document uses *cellphone-repaired.3de* model as an example. The file comes with the 3Data Expert installation in the *tutorials / GeomFiles* folder.

Chapter 1 – Preparing for shell separation

Shell Separation commands allow you to separate surface areas and other components from a repaired shell into separate shells. The separated shells will lay exactly on top of the part they are separated from, and they can be used for defining different material properties (shore value) or different colors in a single part.

In the sequel we will first prepare a file with low quality surfaces for shell separation operation. Of course, most of the time this is not needed, but our intention is to show how to work also on low quality data.

Input cellphone.3de

First open the tutorials > Geom Files > cellphone-repaired.3de file with the *File > Open* command. Accept the proposed units (inch)

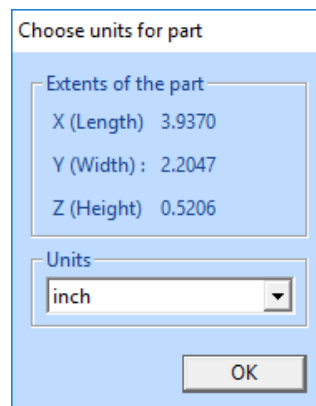

and close the Operation Mode dialog by pressing the *close box* in the upper right corner of the dialog or press *Print Preparation* icon. The model is already fixed so we need not perform any fixing.

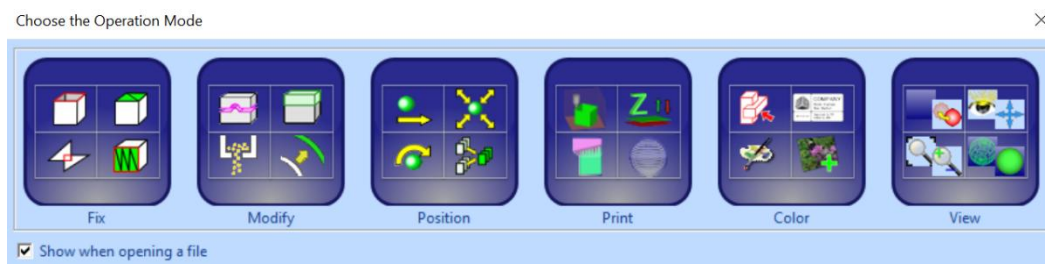

After the input, the cellphone model is visible in the graphics area:

3Data Expert 16.0: Tutorial 3 - Separating Shells

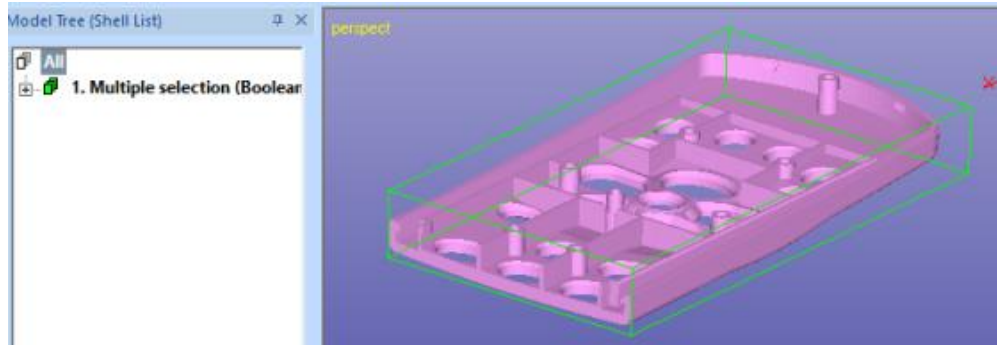

The new shell generation commands are based on surface subdivision of the triangle model. A set of surfaces is first selected, then a solid shell is created from them.

Before we go on with the shell separation, let's check the surfaces on the cellphone model first. Now **turn on the surface edge display** by clicking the Edges button in the Fix tab (to the right of the graphics area). You can also select it from the View > Show Edge Lines menu.



You will immediately see the surface edges displayed with *orange* edge lines:

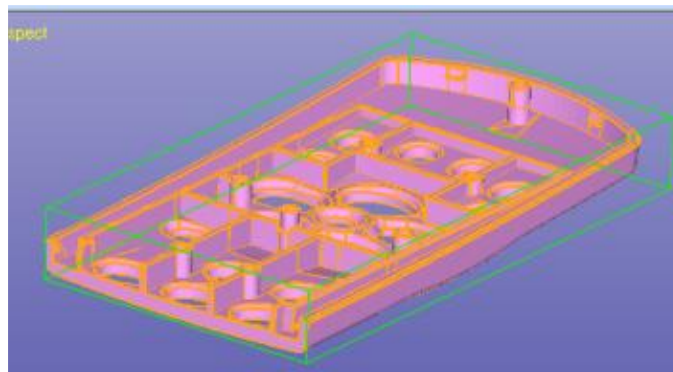

Closer investigation shows that there is an excess amount of surfaces and surface edges. The surface edges have originated from the original input model; it contains several separate shells which were then stitched into one shell.

For example, the largest cylinder fixture on the round end of the part is made of several surfaces, as seen here:

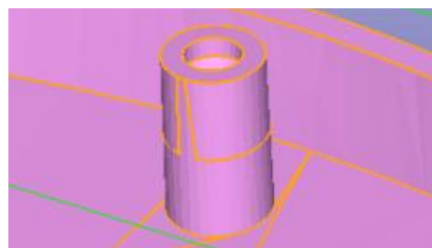

3Data Expert 16.0: Tutorial 3 - Separating Shells

Because we want to separate surfaces on the cylinder into separate shells, let's simplify the surface subdivision first.

The number of shells, surface, triangles etc. on the selected Model Tree object is always displayed below the Model Tree:

Name	All
Shells:	1
Surfaces:	639
Triangles:	24558
⊕ Bounding...	(4.9514, 8.8884), (5....
⊕ Extents:	3.9370, 2.2047, 0.5...
Volume:	0.7618
Area:	24.4138
Project name:	cellphone

Note: When you need more info on how to create new surfaces manually by adding edge lines on the model, please see 3Data Expert 16.0: Tutorial 2 – Working with Colors.

Chapter 2 – Simplifying with the Cleaning Surfaces command

The *Clean Surfaces* command is used to simplify surface subdivision on the part.

- **select first shell** in the Model Tree
- **give command *Fix Model > Clean Surfaces...***

A parameter dialog appears filled with default parameters:

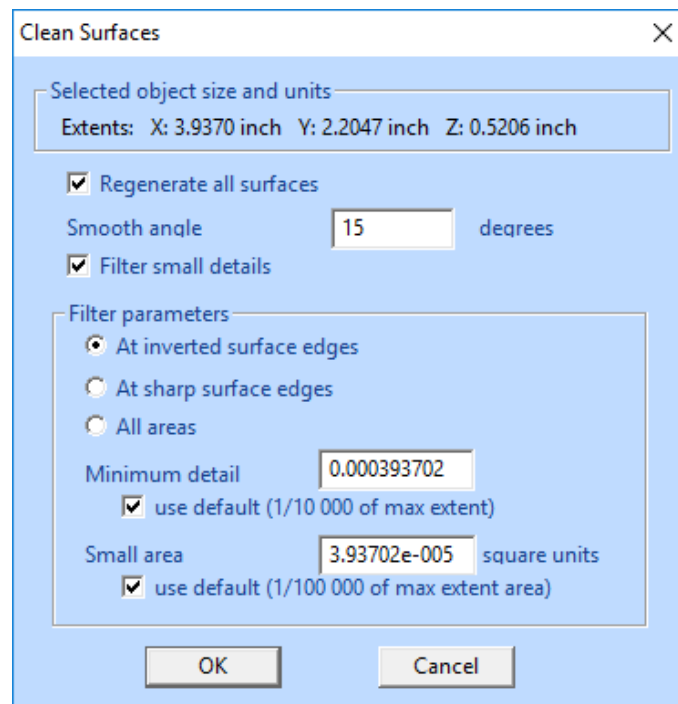

The parameters are automatically calculated based on the part size. This time we will just accept them and reduce the number of surfaces with default settings. The explanation to the parameters can be found in the Help pages.

- **Press *OK*** to start the command

After a while the surfaces are reduced into more meaningful set:

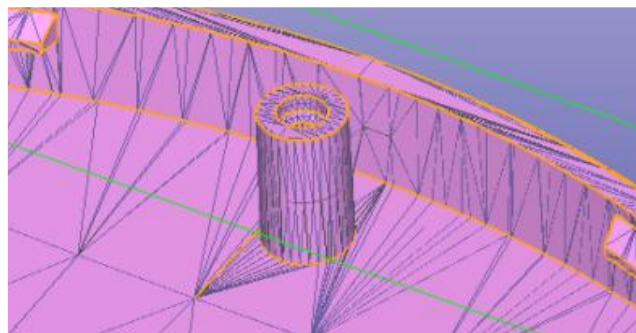

Now we can easily select the surfaces in the cylinder fixture for shell separation. Also, the total number of surfaces is reduced from > 600 to < 300, as see in the below the Model Tree:

Name	1. Multiple selec (Cle...
Surfaces:	273
Triangles:	24188
[-] Bounding	(/ 9514 9 999A) /5

Chapter 3 – Using Offset to Shell command

First we will use offset function to separate shells from the cellphone model. *Offset to Shell* command will offset all multi-selected surfaces and create new shells from them.

First **set on the Surface selection mode** through the *Selection mode* buttons:



Let's now select the surfaces for shell separation:

- **rotate and zoom** the view to see the surfaces to select
- **use graphical multi-selection** (CTRL + left mouse button) to select the four (4) adjacent surfaces as seen in the image below

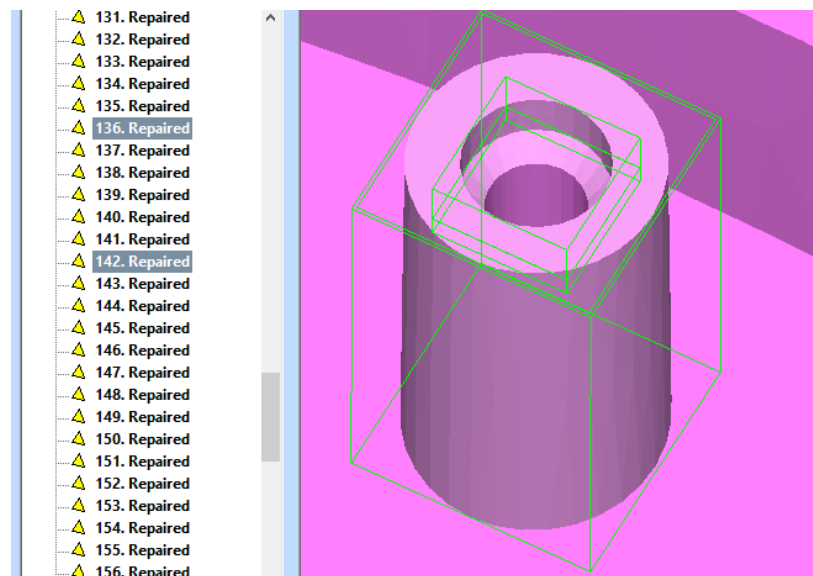

- give command *Modify Faceted > Separate to Shell > Offset to Shell*

After the command, a parameter dialog is displayed with default parameter values. **Fill in the values given below (0.01 inch) and uncheck the use default check box:**

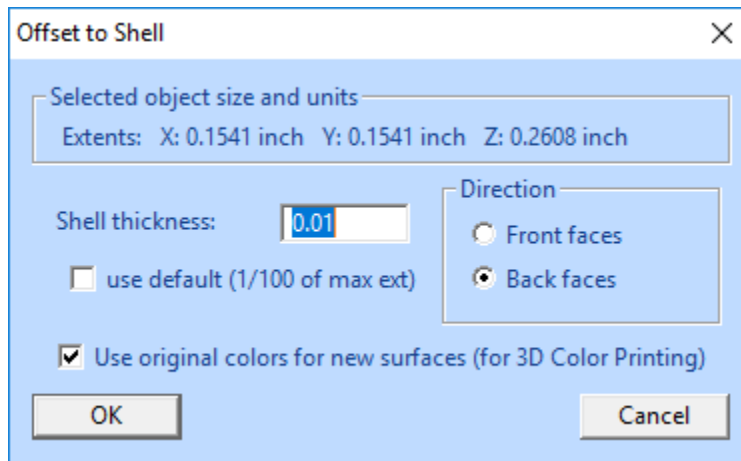

The given settings will produce a solid offset of the selected surfaces. The offset will be inside the mode (*Back faces*) and the thickness will be 0.01 inches. Normally, you should use as small a thickness as possible to avoid potential errors with the offsetting.

- **Now press OK to generate the separate shell** from the selected surfaces.

After a while you will see the result in the Model Tree. The original shell is now selected and stored as the last shell in the Model Tree and the separated smaller shell(s) is just in front of the original shell. The suffix *Separated* is added to the name of both shells.

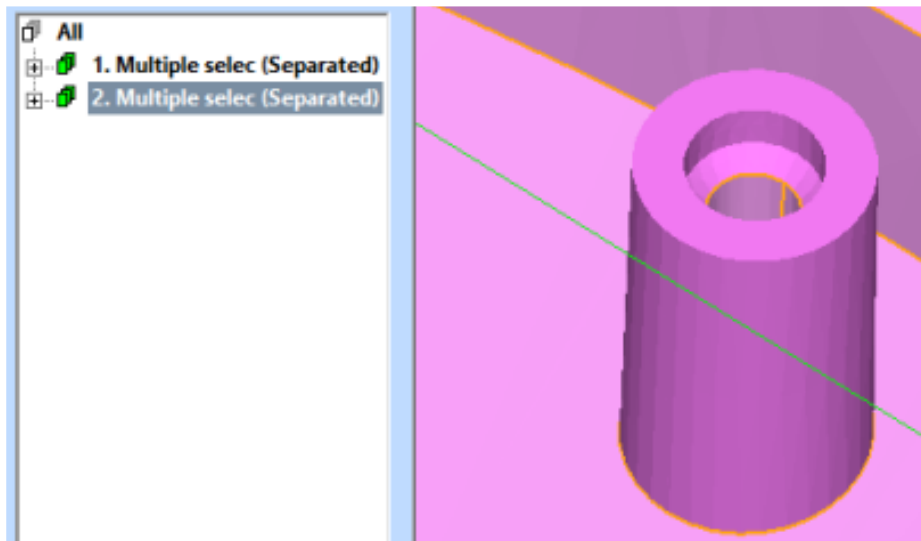

For clarity, lets now rename the shells with names describing their material composition and to later correctly output them to disk files. We will rename the first shell (from the cylinder) as *cyl-shore-50-1* and the original part with *cell-shore-20-1*, as seen in the image below (the shore value is used to describe the “rubberness” of a material):

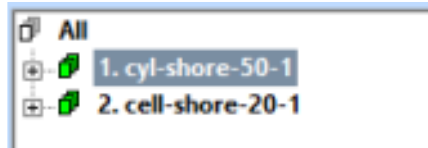

Shell 1. *cyl-shore-50-1* is a fully separate solid shell, lying on top of the original model (with the corresponding cylinder now shrunk). The thickness of the shell is approximately 0.01 inch, and it follows accurately the cylinder left in the original model (the display mode of *cyl-shore-50-1* has been changed to wireframe):

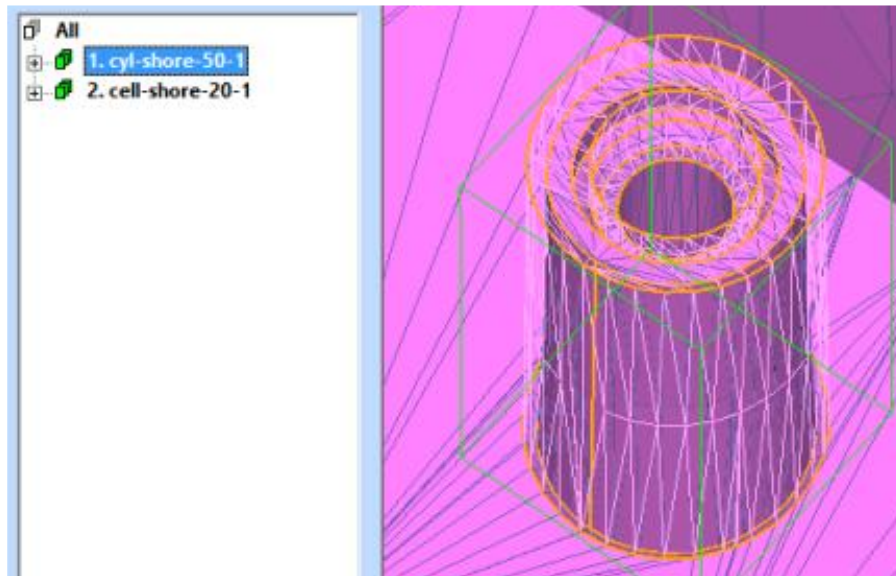

Chapter 4 – Using Extrude to Shell command

We will next use the extrude function to separate shells from the cellphone model. *Extrude to Shell* command will extrude all multi-selected surfaces in a model and create new separated shells.

First, we will select suitable surfaces for shell separation in the model:

- set **Surface selection** mode on
- rotate and zoom to a suitable viewpoint
- use **graphical multi-selection** (CTRL + left mouse button) to select the two long and thin surfaces going around the model as seen below

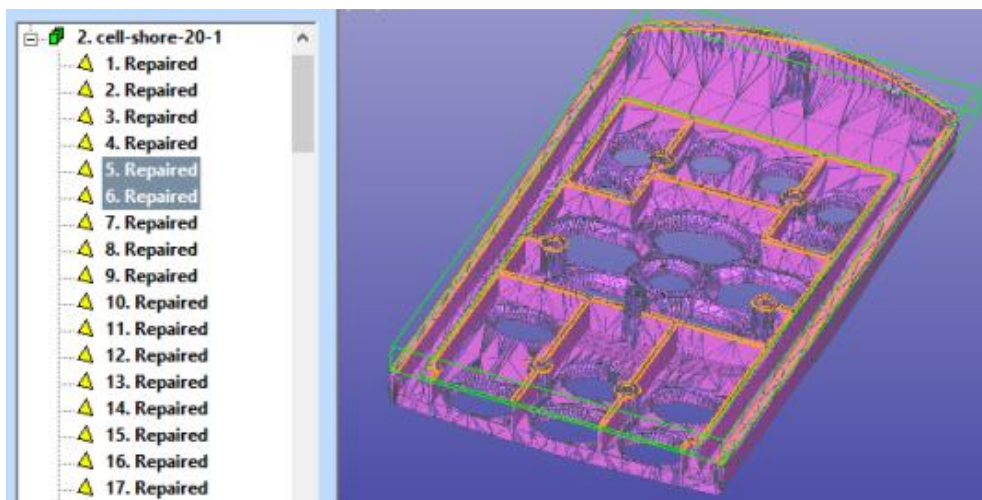

- give command **Modify Faceted > Separate to Shell > Extrude to Shell**

After the command is given, a parameter dialog is displayed with default parameter values. **Fill in the values given below** (*thickness 0.01 inch*), direction *Avg. normal* (average surface normal) and *uncheck* the *use default* check box:

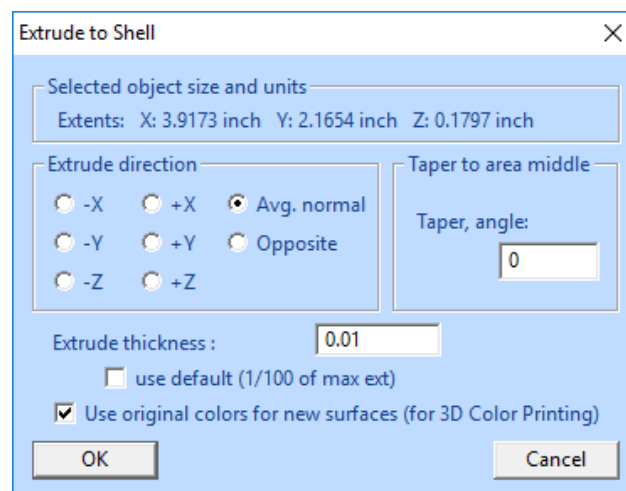

Our goal is to create a thin separate shell on top of the original model walls. *Extrude to Shell* can be used especially when a separate shell is created by adding material on top of the original model.

Note: Tapering is useful when extruding convex areas towards the inside the model, to avoid surface intersections at the extrusion area edges. Normally you should use Offset to Shell when separating shells towards the inside of a part, as seen in the previous example.

When ready,

- **press OK** to generate the new shell on top of the thin walls.

After a while you will see the results in the Model Tree. The original shell is, once again, the last shell in the Model Tree and the two new shells just in front of the original shell. The suffix *Separated* is added to all resulting shells.

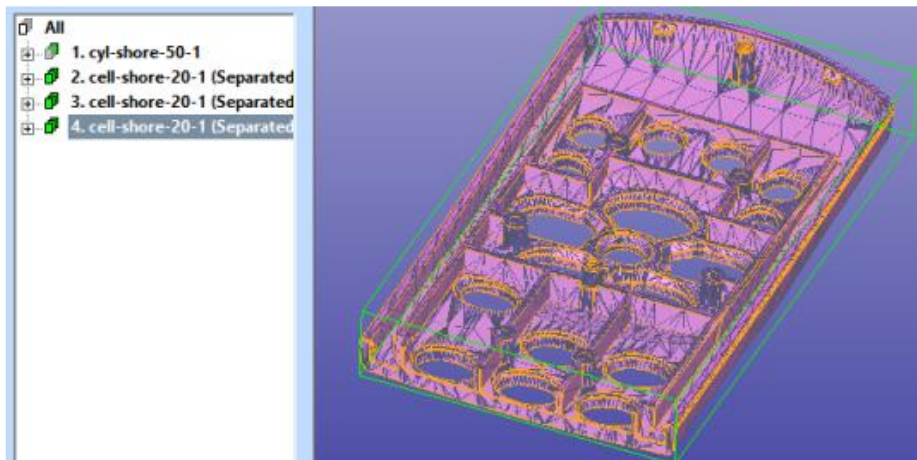

Rename the new shells with unique names, *edge-shore-50-1* and *edge-shore-50-2* as seen here:

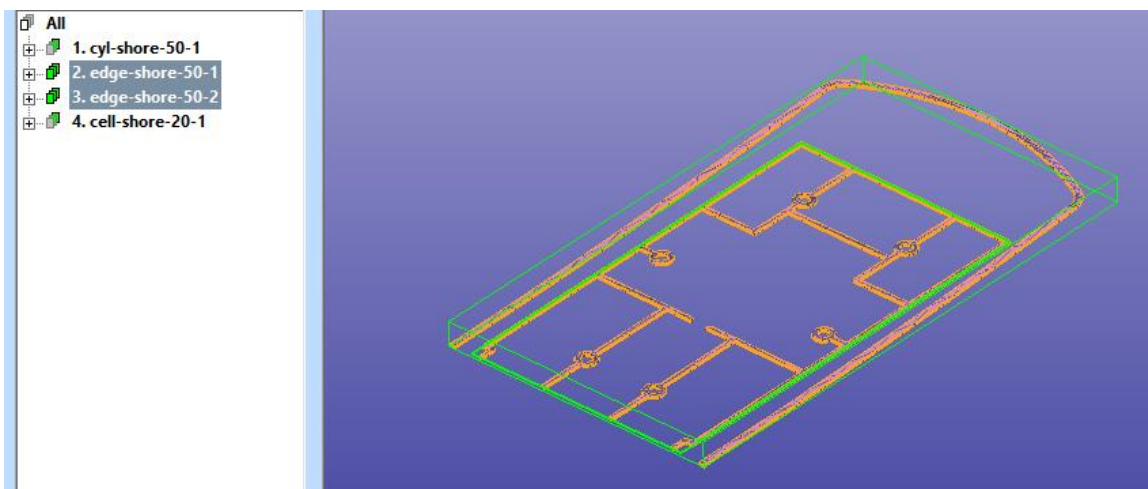

Chapter 5 – Using the Fill to Shell command

The final special shell separation command is the *Fill to Shell* command. This command will separate and fill all multi-selected surface sets and create new separated solid shells.

The *Fill to Shell* command is best applied to a set of surfaces which form an almost closed volume, or where the gaps created at the separation can be filled with normal gap fill. For example, the four small fixtures in the cellphone model meet this criterion. One of the suitable fixtures is circled here:

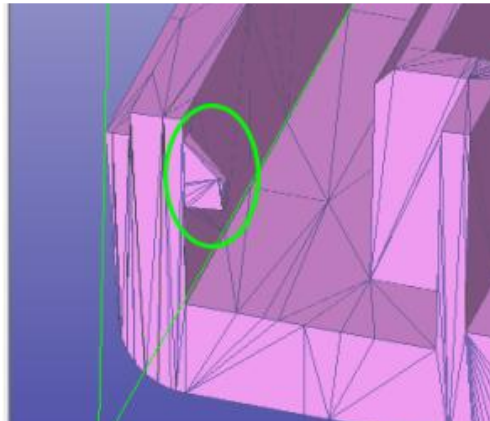

Now let's separate the surfaces making the fixture into a separate shell:

- **set *Surface Selection* mode on**
- **use graphical selection to select the surfaces** show in the image below (*Ctrl + LMB* or *Alt + LMB* for rubberband selection)

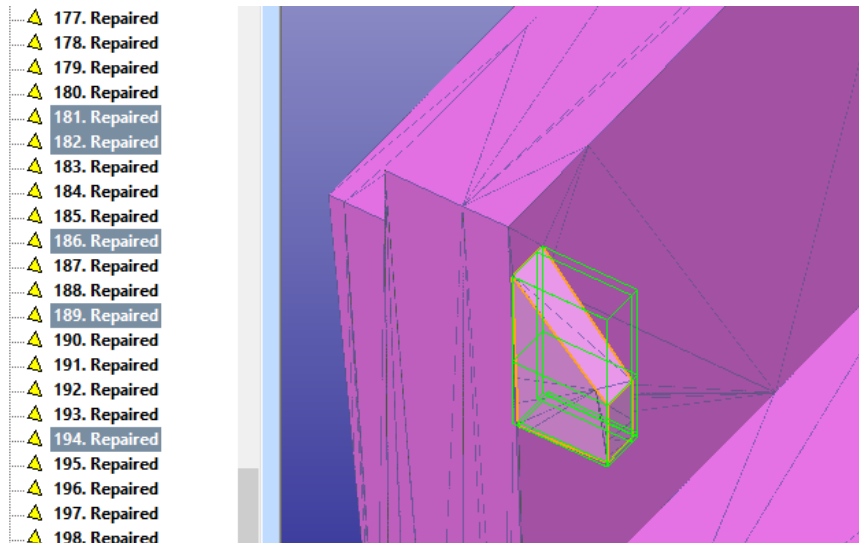

- **give command *Modify Faceted > Separate to Shell > Fill to Shell***

After a while you will see the fixture separated and the solid result in the Model Tree. The last shell in the Model Tree will again be the original part and the shell above it is the small, separated fixture:

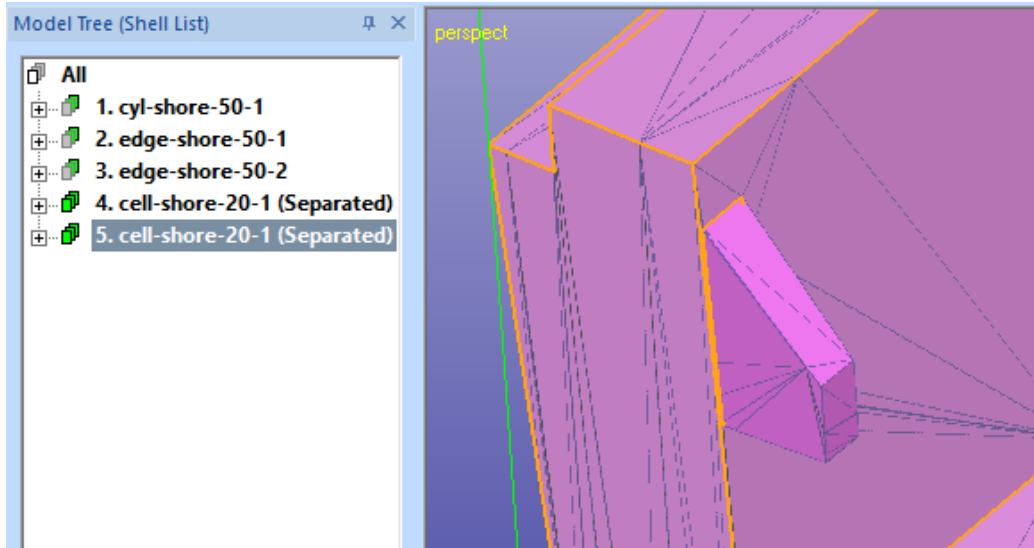

Rename the fixture with a suitable unique name (*fixture-shore-50-1*) for output:

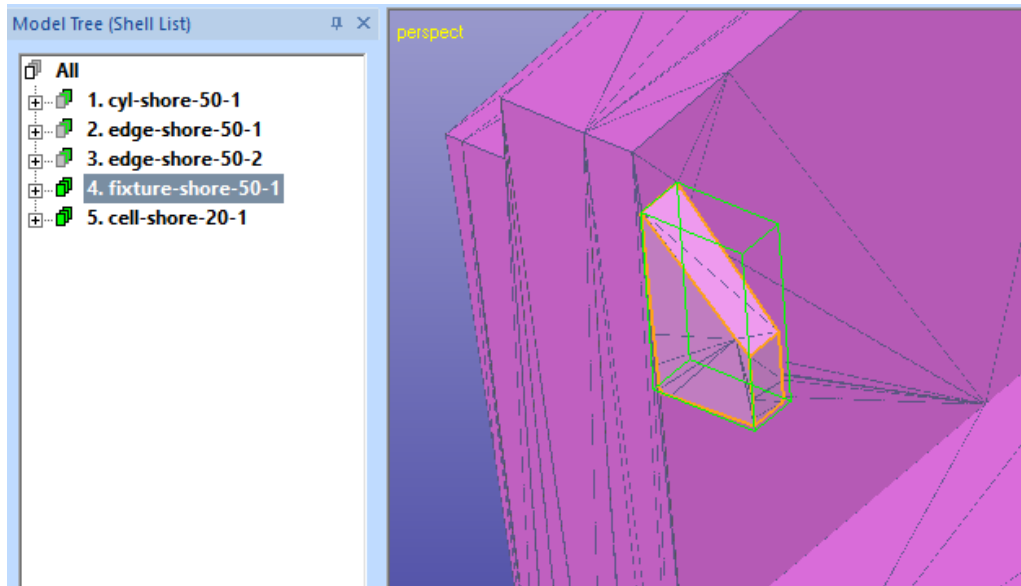

Outputting separate STL files

To finish the shell separation process we want to output the shells into separate STL files. We already have named each shell with a unique name which will be used for the disk file names too, as seen in the image below:



To output the files

- select Model Tree root **All**
- from the menu, open **File > File Options**, then in the File Options dialog, set **File Save options > STL > Separate files** to **Yes**, and click **OK**:

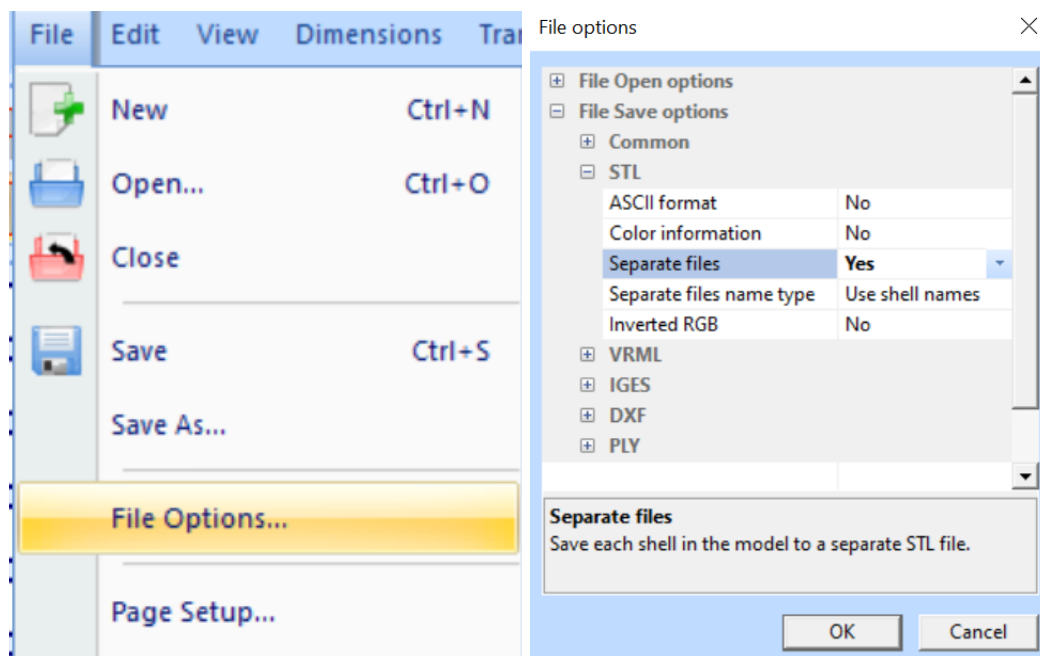

- give command **File > Save As...**
- make sure **STL (.stl)** file type is selected. File name does not matter here, because the file names will come from shell names

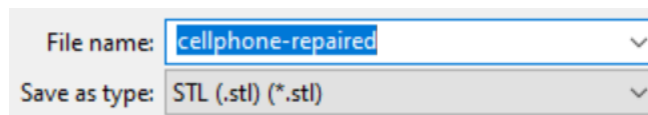



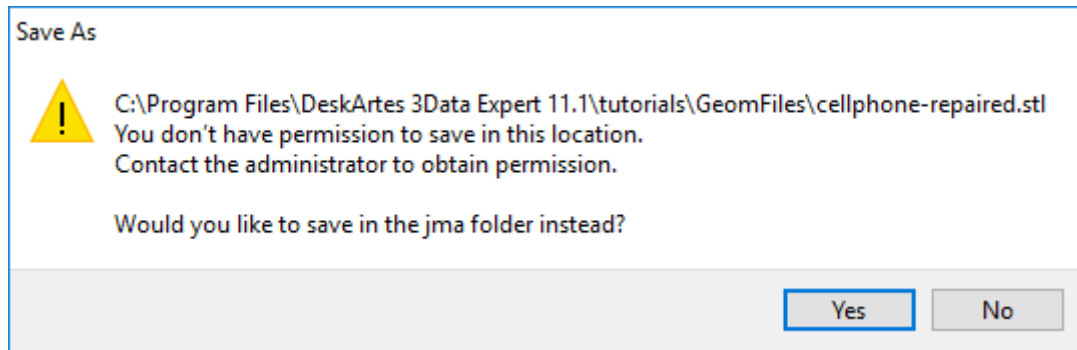

- press **Save** in the Save As dialog

If you get a following dialog complaining the permission to save, **press Yes** and select a folder where your user account has write access.

3Data Expert 16.0: Tutorial 3 - Separating Shells



The shells are written in separate disk files with the shell names. These files can be inputted to receiving 3D printing system for different color or material settings.

 cell-shore-20-1.stl	STL File	1 185 KB
 cyl-shore-50-1.stl	STL File	46 KB
 edge-shore-50-1.stl	STL File	159 KB
 edge-shore-50-2.stl	STL File	53 KB
 fixture-shore-50-1.stl	STL File	3 KB

After saving the files, do not forget to **go back to File > File Options** and switch **STL > Separate files** back to **No**. Otherwise, when saving STL files, you may get different file names than you really want.

Chapter 6 – Using Cut Tool to separate shells

The easiest and most recommended way to generate separate shells from a part is described in Chapters 1 to 5. In this and following chapters we will look at some other efficient but less straightforward methods to create separate shells from a connected model.

One efficient way to generate separate shells from a solid shell is to use *Modify Faceted > Cut Tool* command. This chapter will show you how to use it.

First open the cellphone-repaired.3de file with the *File > Open* command. Accept the proposed units (inch) and close the Operation Mode dialog by pressing the close box in the upper right corner of the dialog. The model is already fixed so we do not need to perform any fixing.

We will first separate the largest fixture in the round end of the cellphone model:

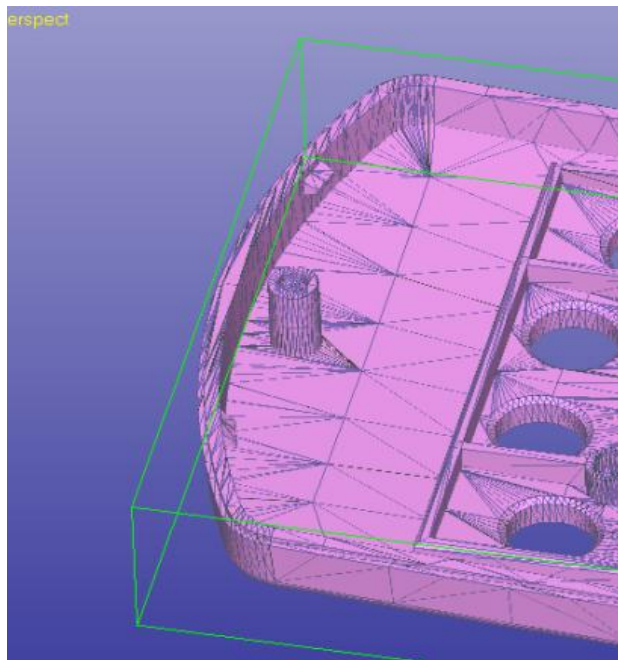

Separating the largest fixture

To separate the fixture, start with the following commands:

- **take a view** from the Z axis direction
- **select the 1. Multiple selection (Boolean)** shell from the Model Tree
- **give command Special Modify > Cut Tool**, a Cut Tool dialog appears
- make sure **Draw surfaces selection is set** in *Create cutter with* group
- **select Curve type** in *Draw cutter with* group because now we want to draw a smooth curve around the separated area instead of a polygon

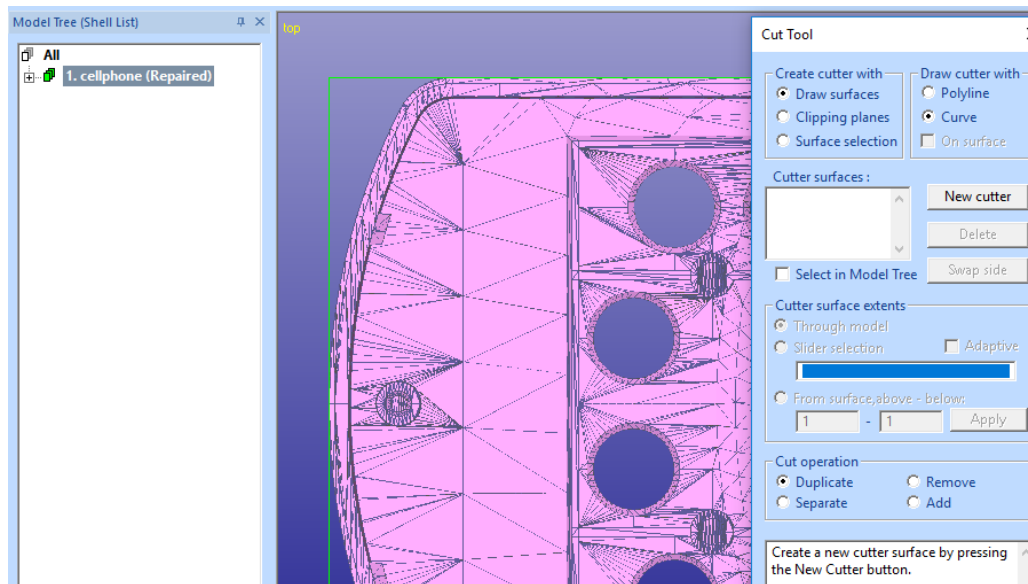

Then we continue to draw the separated area:

- zoom closer to the model, if necessary
- **press *New cutter* button** to start inputting curve around the fixture
- **continue adding curve points** with the crosshair icon evenly around the fixture so that the curve does not overlap the vertical walls of the fixture
- when ready, **close the curve by picking the first point again** with the crosshair icon
- you may **select and move the curve points with LMB (left mouse button)** so that the curve is evenly around the fixture

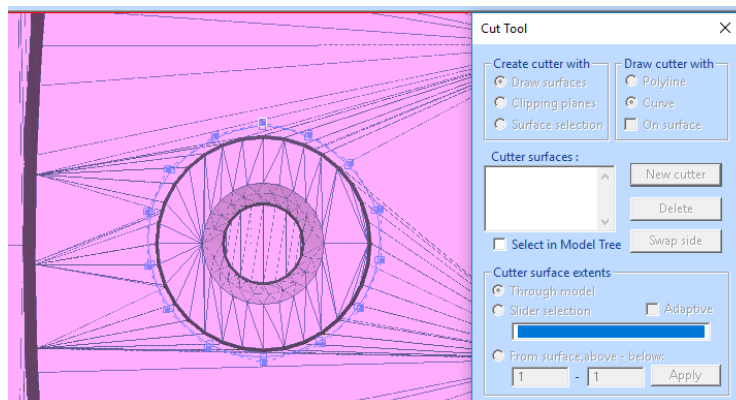

Now the curve is drawn correctly around the fixture. To finish the cut tool generation

- **press RMB (left mouse button)** to finish the curve edit

3Data Expert 16.0: Tutorial 3 - Separating Shells

- the ***cutter 1 tool appears*** in the Cutter surfaces list and Model Tree and is displayed on the graphics area (rotate the view to see it)

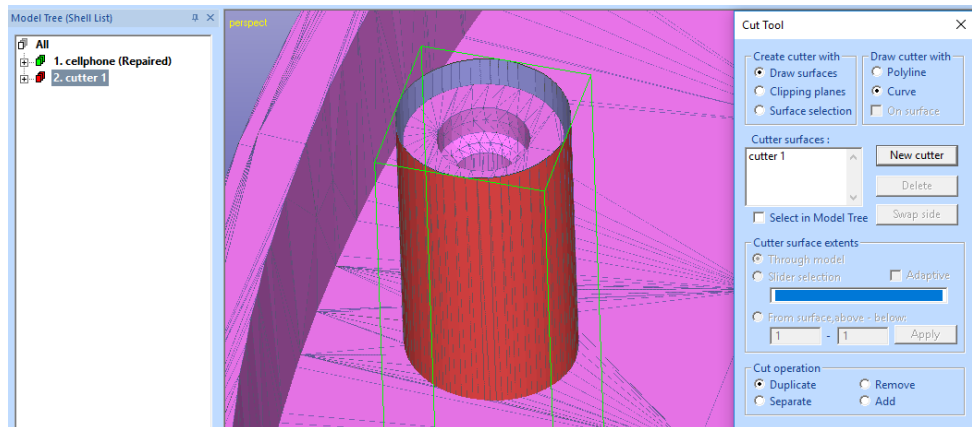

Now we will tune the cut tool to correct depth:

- **select the *cutter 1*** in the *Cutter surfaces* list, this will allow us to fine tune the tool depth
- **select *Slider selection*** in the *Cutter surface extents* group
- **open Clipping Tab** by pressing  icon
- **use Y clip plane** to see the cut tool to go through the whole model

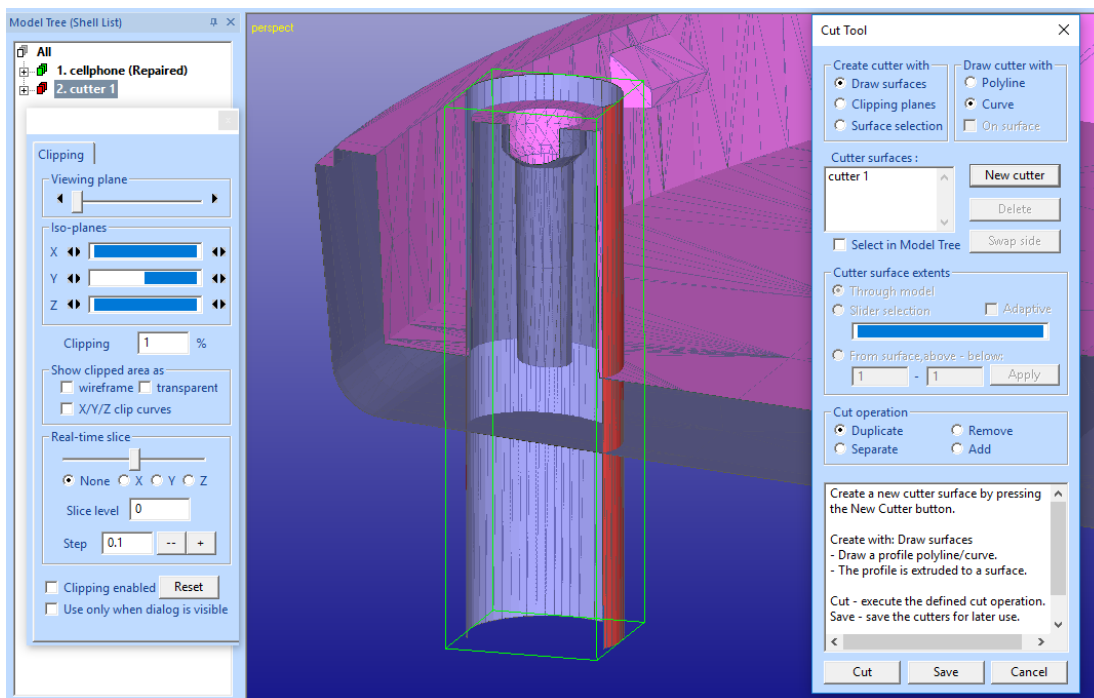

3Data Expert 16.0: Tutorial 3 - Separating Shells

Now you can set the correct depth for the cut tool. We do not want to go through the whole model, we only want to separate a shell with sufficient contact to the original part:

- **start moving the slider** in the *Cutter surface extents* group
- you will see a bounding box with the maximum extent of the cut tool displayed
- **move the left end** of the slider towards the right end with LMB
- the bottom plane for the cut tool is displayed in the bounding box and the tool is cut accordingly, please see on the image next page.

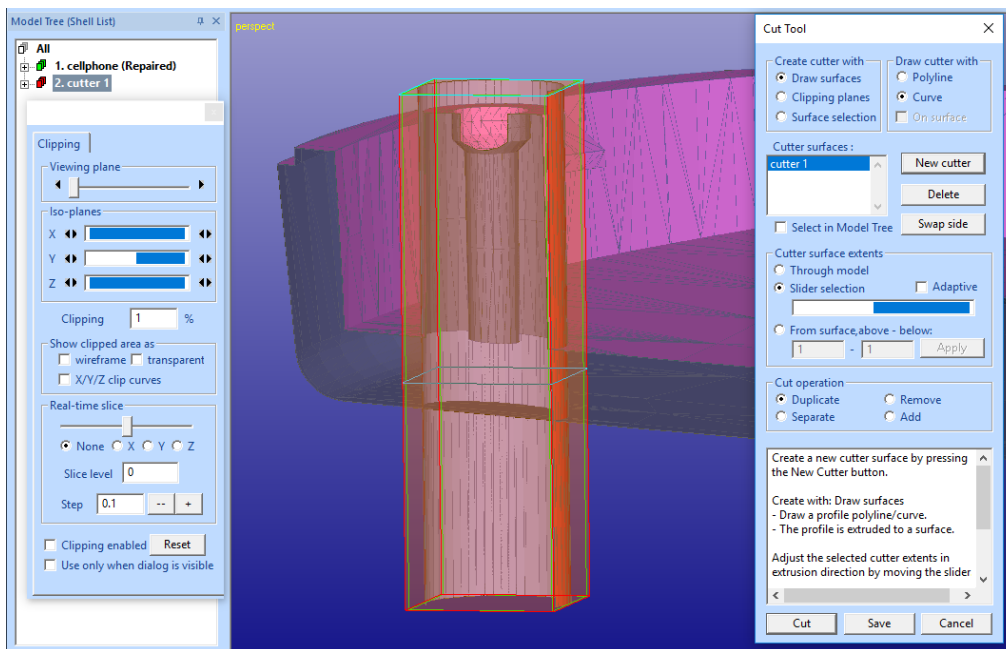

Fine tune the cut tool depth:

- **move the slide left end** until the cut tool bottom is somewhere in the middle of the cellphone model, as seen in the image below. The cut tool must be fully intersected by the surfaces in the cellphone body:

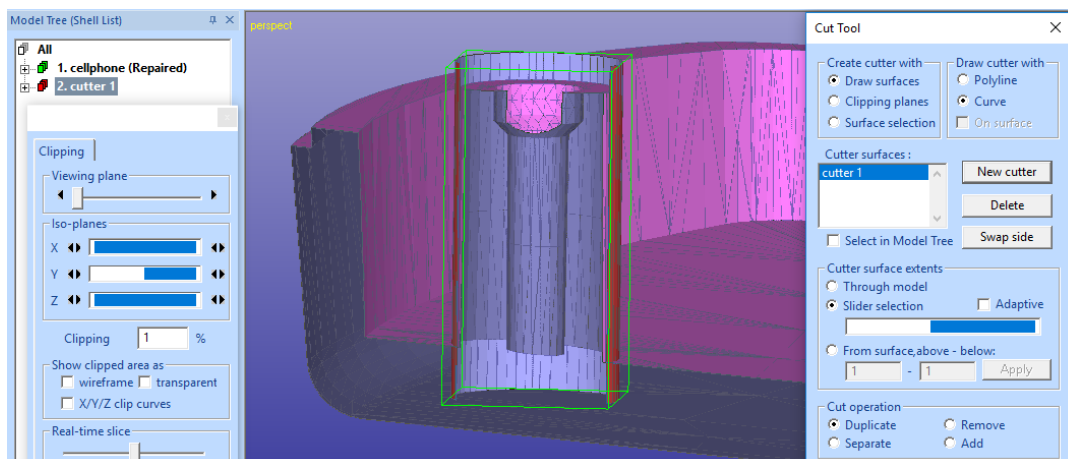

Now we are ready to select the correct operation and to apply the cut tool:

- select **Separate operation** in the *Cut operation group*
- press **Cut button** to apply the *Separate* operation

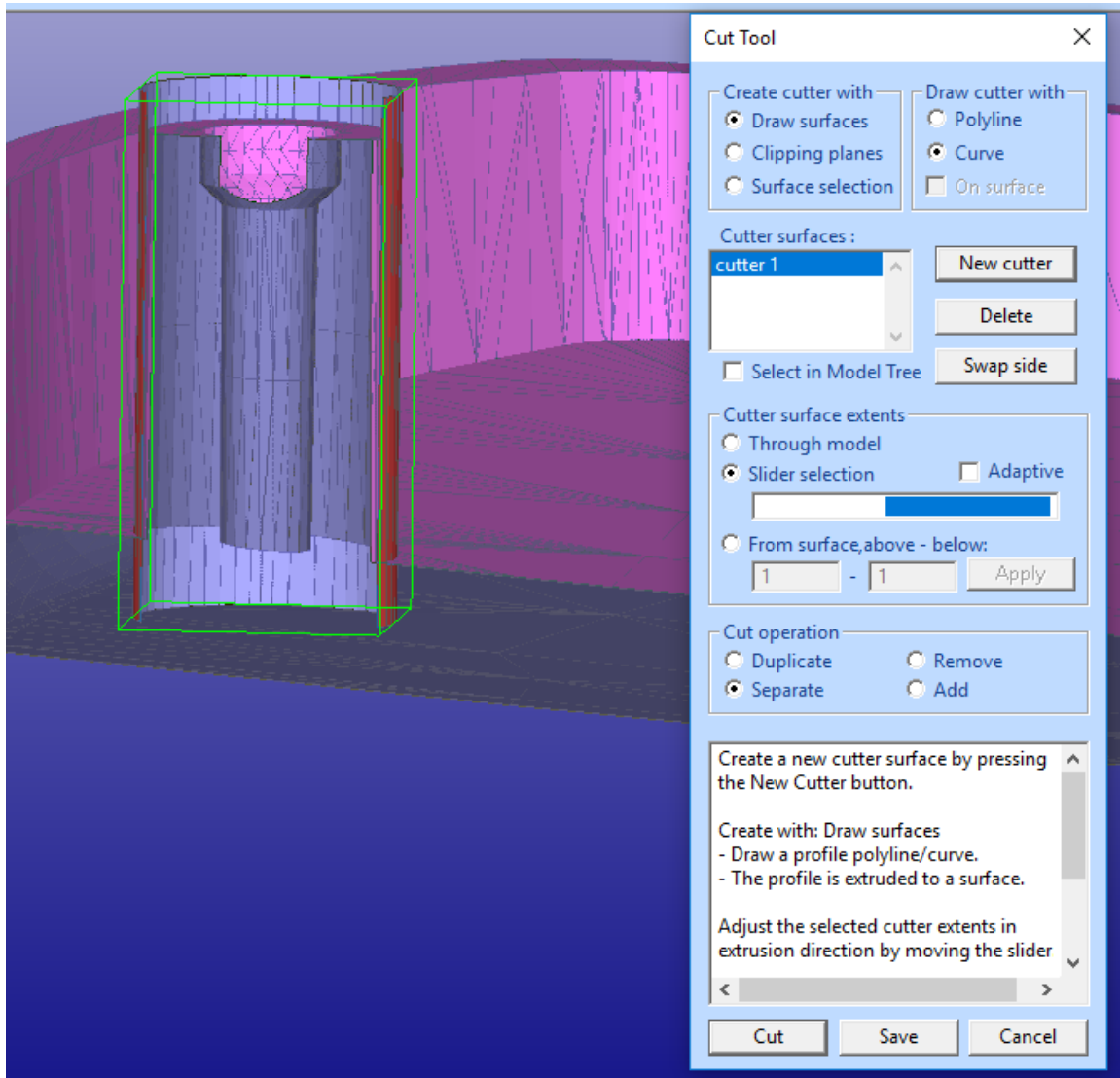

You will soon see the cut fixture on the graphics area:

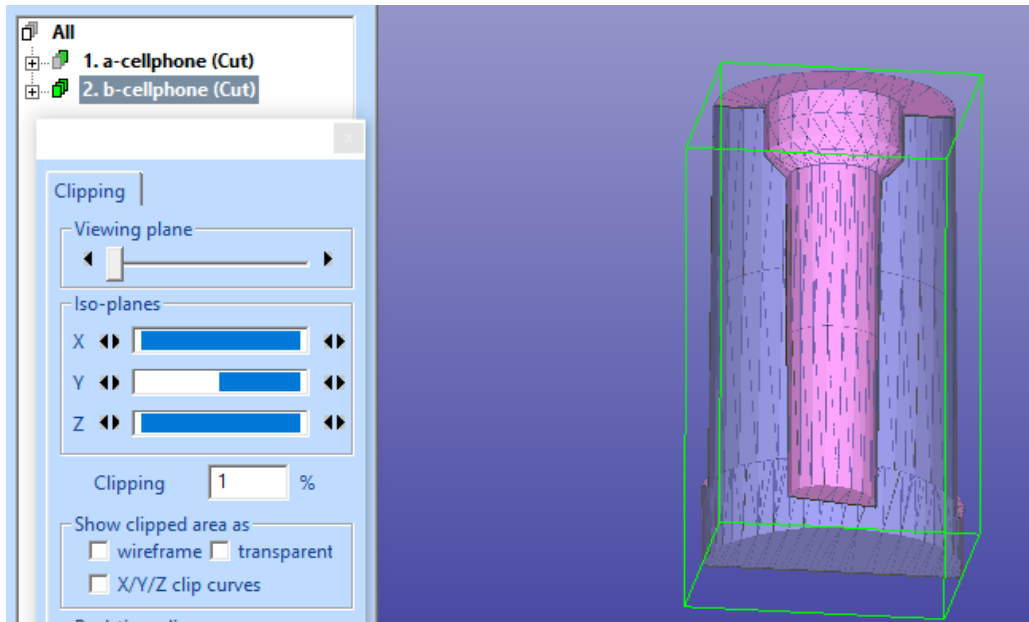

And the cellphone body has corresponding hole:

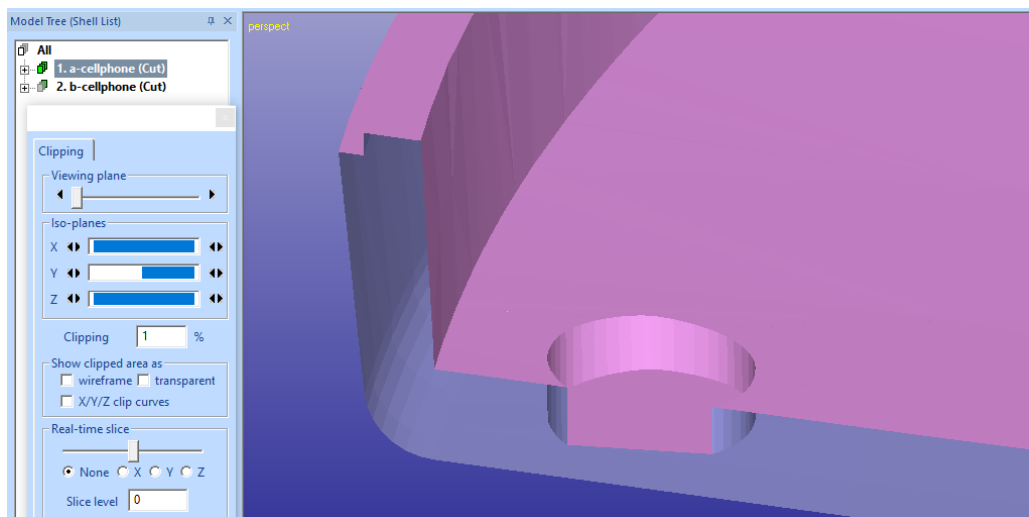

You may need to run Fix Model > Repair to the body to get rid of minor gap generated to the body during Boolean operation topology generation. Finally, you will have the two separate shells available for different shore value definitions.

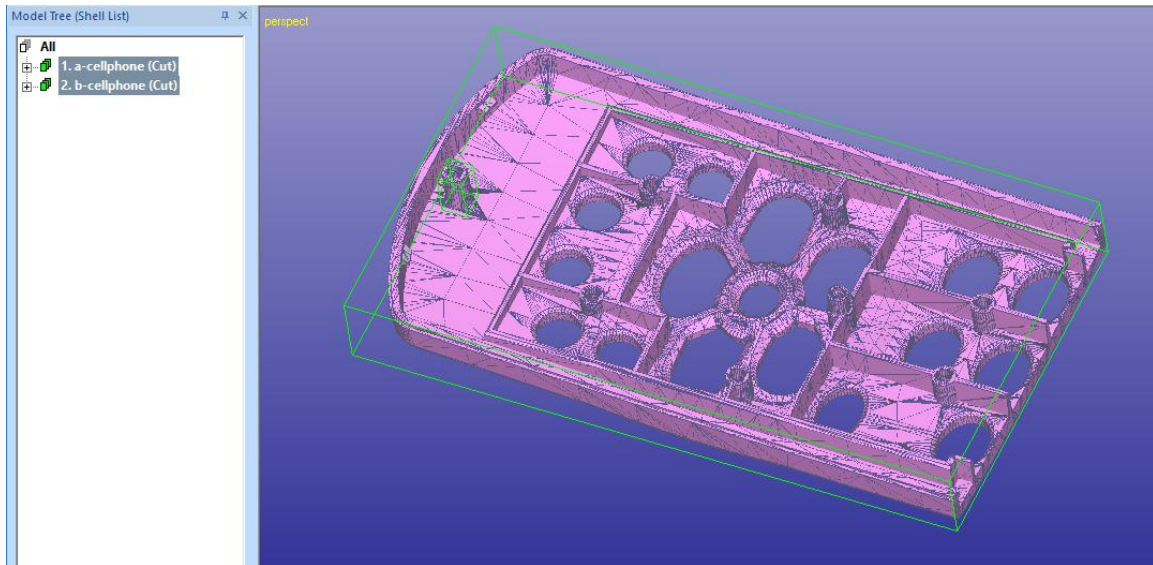

Renaming shells and outputting STL files

You may select and store each shell into a separate STL file just by selecting them in the Model Tree one by one, giving *File Save As* command and defining suitable file name during the file save.

You can also output each shell into separate STL file with one command and in a more controlled fashion. For example, the following process would allow you to plan and indicate the correct shore value for each shell before output:

- **rename the two shells** through RMB menu on the Model Tree with indication on the desired shore value, *a-cellphone-s50* and *b-cellphone-s20*, for example. You must make sure that all shell names are different.

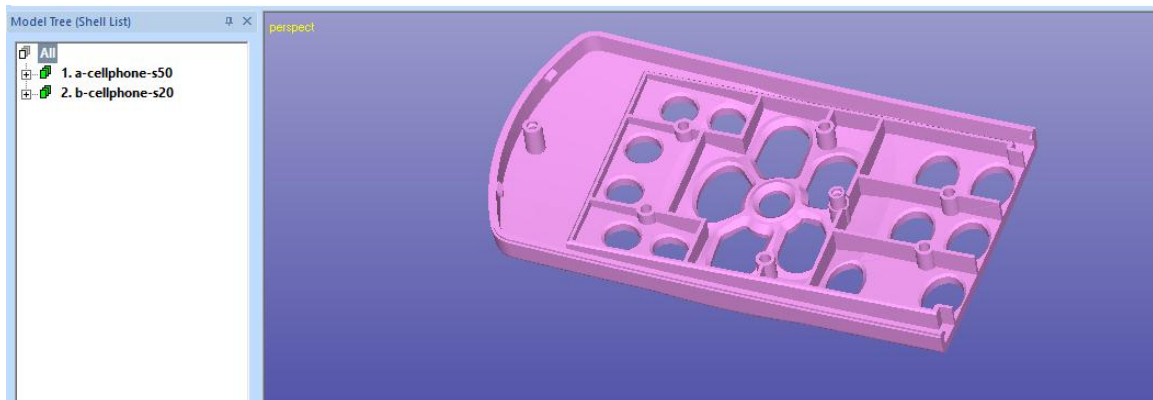

- to save the STL files, follow the same procedure as earlier in **Outputting separate STL files**

And you are ready, the files with names *b-cellphone-s20.stl* and *a-cellphone-s50.stl* are stored on the hard disk.

Emulating material properties with colors

You can emulate the final print result by setting different colors to the shells using the Color tab commands. Please see *Tutorial 2 – Working with Colors* for more details on painting objects. Colors can be seen when the 3D Color Printer mode is set with the  icon (Note: only colors are available, transparency cannot be defined).

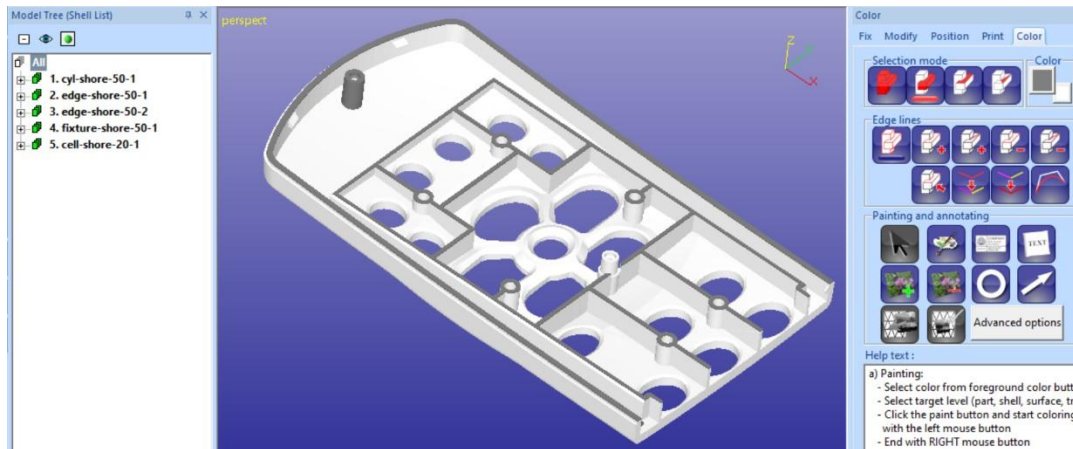

More cutting planes

The *Cut Tool* allows you to define *any number* of cutter planes and they do not need to be closed tubes as used in the example above. You just need to make sure that the cutter planes are drawn in consistent order for consistent inside/outside separation, please see more at Help pages for Cut Tool command. Generally, the inputted points for different cut planes should be given either in clockwise or counter clockwise order around the middle of the area to be separated.

Multiple cutter planes can be used to separate geometries in very complicated topologies accurately, like in medical models:

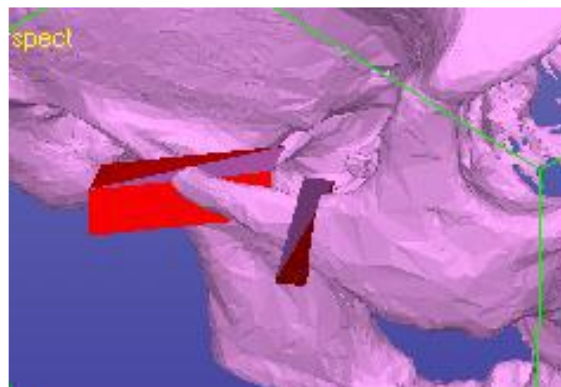

Using Hole Tool to separate small flat surface areas

The *Special Modify > Hole Tool* command can also be used to separate simple areas from a solid STL model. It works in similar fashion as Cut Tool command, you first define a tool to apply on the model and then separate the desired area. With Hole Tool you can only create circular (smooth or polygon) tools on top of the surfaces.

In the image below we have generated and tuned a circular area on the other side of the cellphone model for separation:

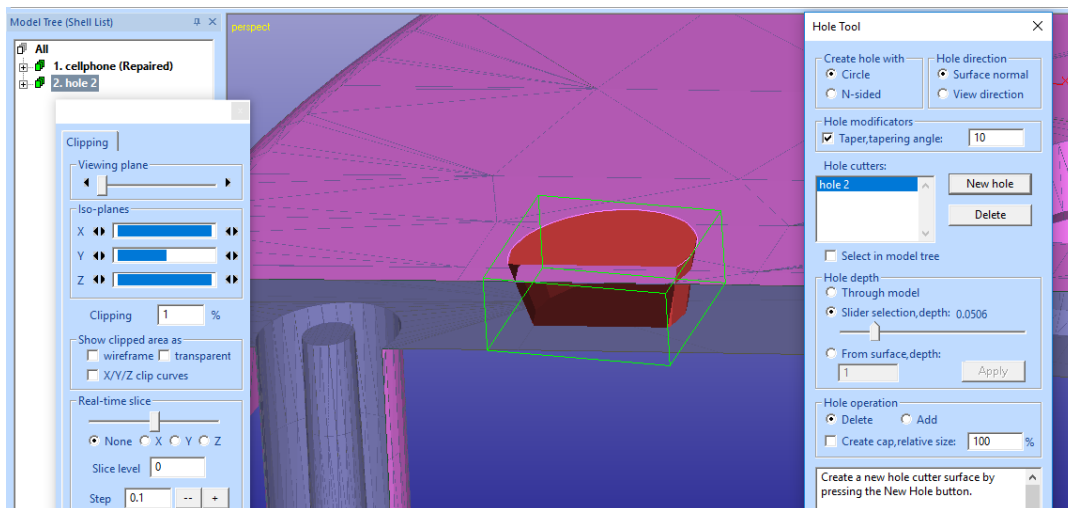

When the depth for the separated round area is correct, select the correct operation parameters (*Delete* and *Create cap*) and **press Create** button:

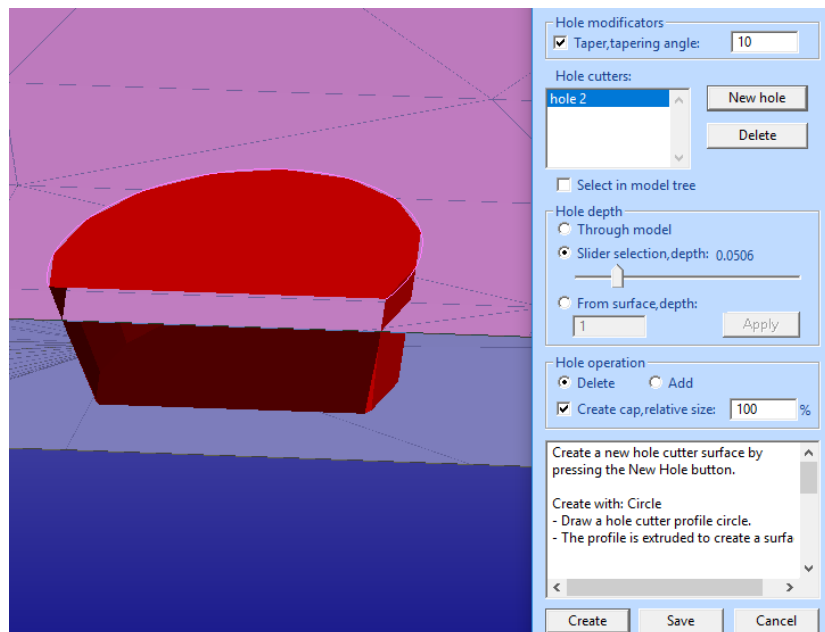

3Data Expert 16.0: Tutorial 3 - Separating Shells

After a while you will have a round area separated into a new shell:

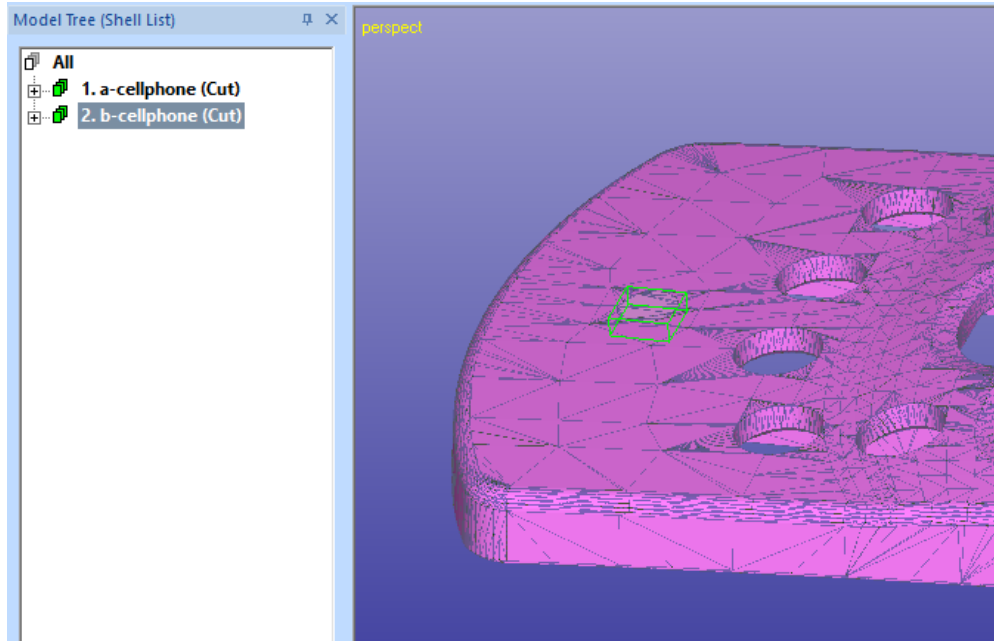

In case of errors in one of the separated shells, please run *Fix Model > Repair Shells* command on the error shells (*1. a-cellphone (Cut)*) to get fully correct components.

Chapter 7 – Using Extrude to separate shells

This Chapter shows you how to use *Fix Model > Edit Triangles* to create new surfaces for shell separation with the *Create Geometry > Extrude Surface > from Surface* command.

Creating surfaces with Edit Triangles command

Edit Triangles command allows you to select any triangles and separate them into a new surface for the Offset or Extrude command. We will use the same cellphone-repaired model for this example too.

Start by:

- **input the *cellphone-repaired.3de* model**, continue through the units and Operation Mode dialogs
- **take a view from -Z direction (bottom)**
- **select Model Tree root *All***
- **give *Fix Model > Edit Triangles* command**
- **use *LMB* to select desired triangles** from the model, as seen below, grayed

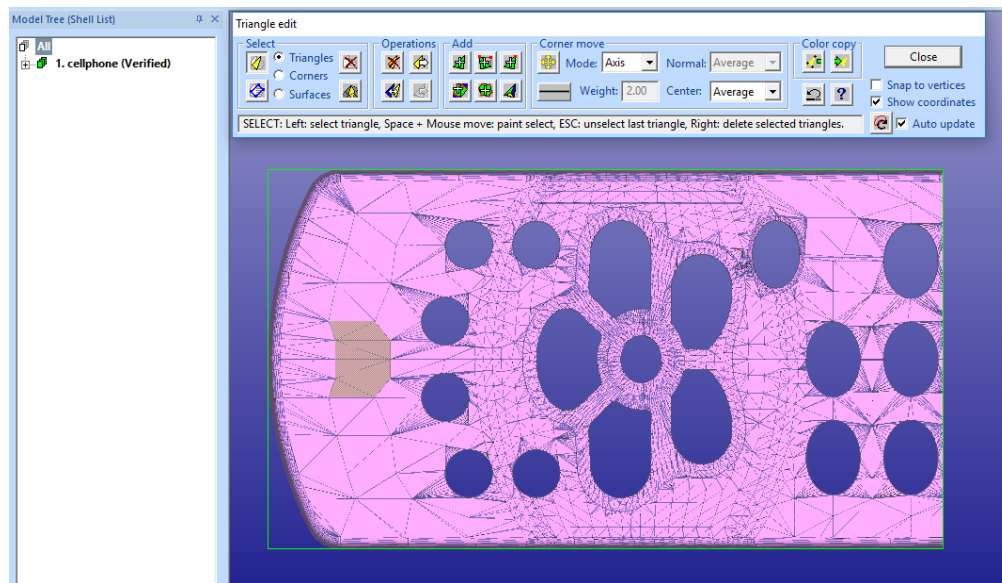

When you have selected the triangles, it is time to separate them into a new shell. We have the Model Tree *All* selected; this causes the separated triangles to be stored automatically into a new shell:

- **press the  icon** to create a new shell for the triangles

3Data Expert 16.0: Tutorial 3 - Separating Shells

A new shell is created in the Model Tree, 2. *Separated triangles*. Also, gaps shown on the graphical area indicate that the two shells are no longer solid.

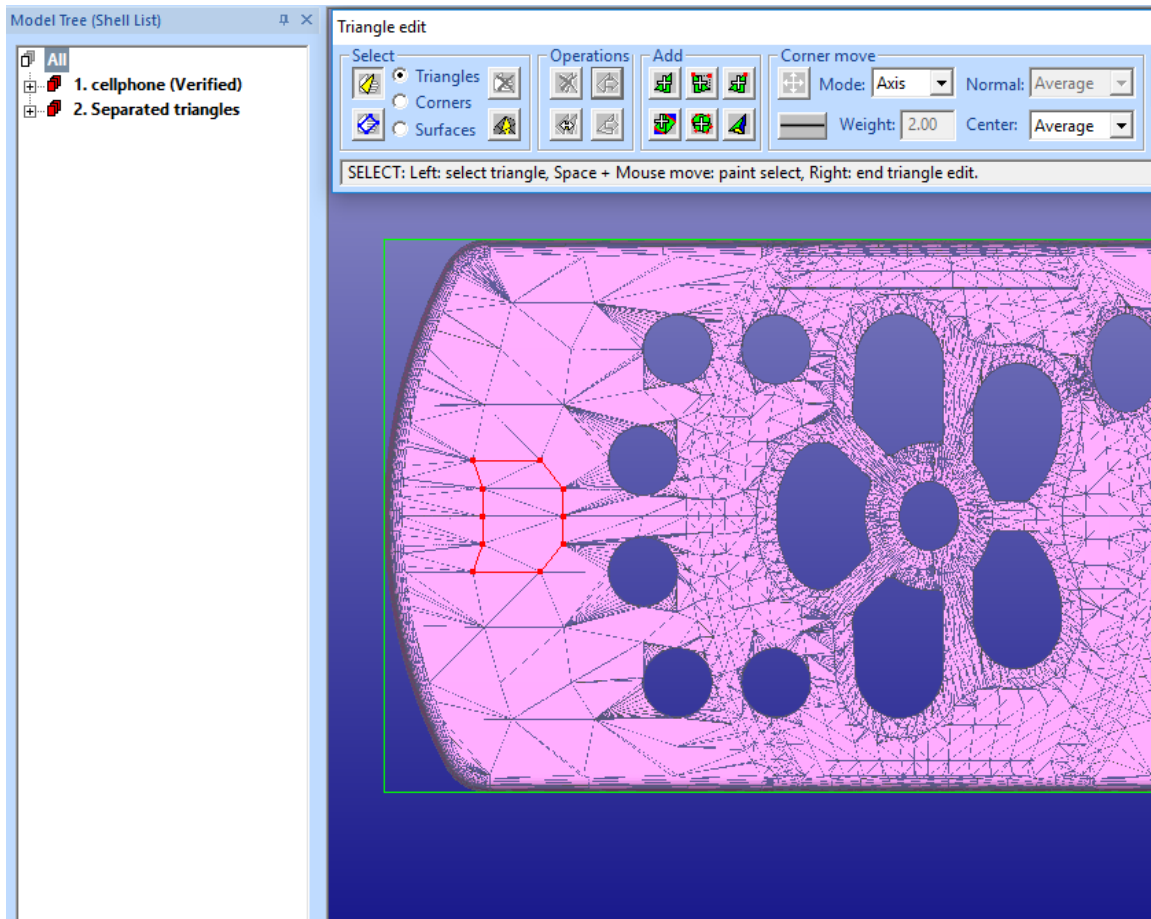

- then **press Close button** to end Edit Triangles

Using Extrude from Surfaces command

Extrude from Surfaces command can be used to extrude surfaces from solid shells or flat/open shells. We can either select the 2. *Separated triangles* shell or the surface in it for the extrude command. Let's do the following:

- **select the 1. Triangles surface** in the 2. *Separated triangles* shell
- **give Create Geometry > Extrude Surface > from Surface** command
- **fill in parameters** as seen in the image next page (*Direction Opposite* and *thickness 0.01 inch*)

3Data Expert 16.0: Tutorial 3 - Separating Shells

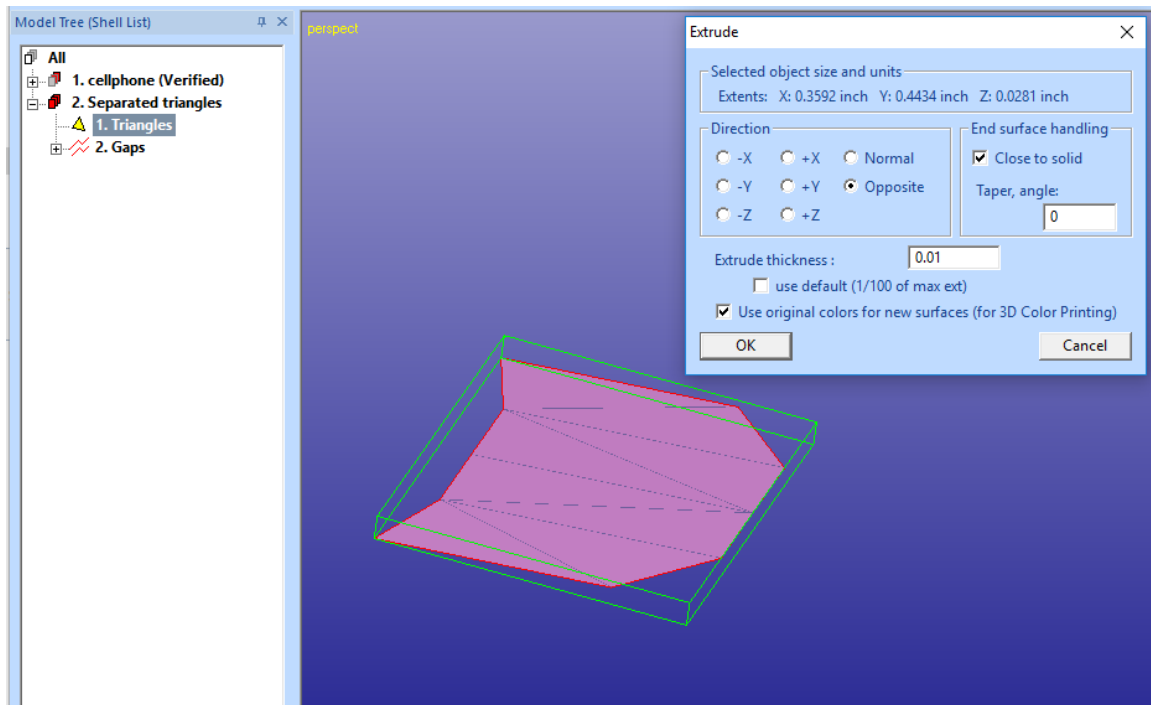

We will generate an extrude towards the inside of the original model (Opposite) and with 0.01 inch thickness.

- **press OK** to create the extrusion

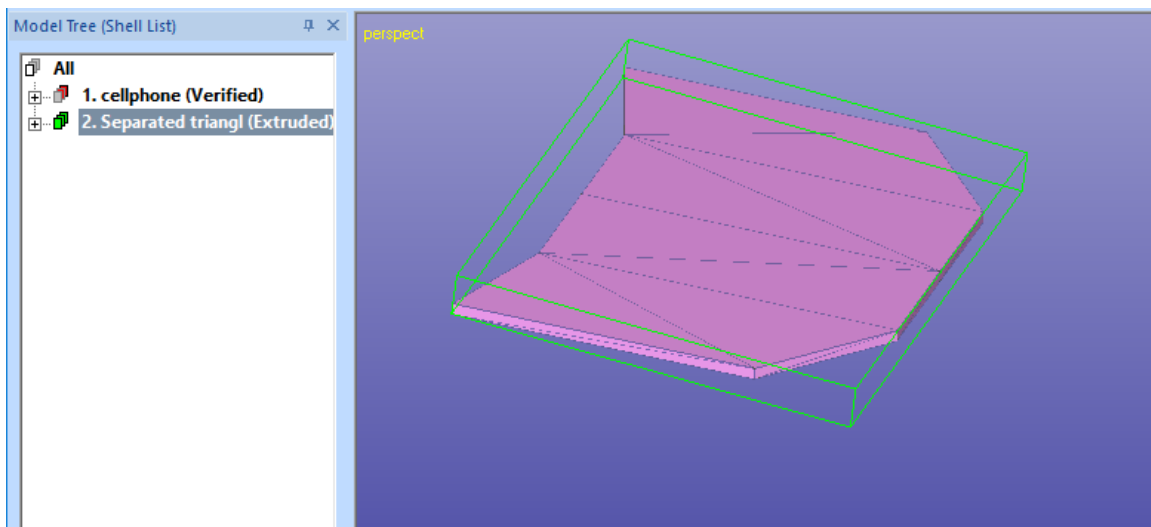

The result is a solid shell with the given thickness.

The original cellphone shell is still open and missing the corresponding blind hole on the surface. We now need to move the new surface generated by the Extrude command from the 2. shell into the 1. shell.

Copying Extruded surfaces to original shell

We will select all surfaces generated by Extrude and copy them into the original shell to make it solid again:

- **select all surfaces except the original surface** taken from the cellphone model

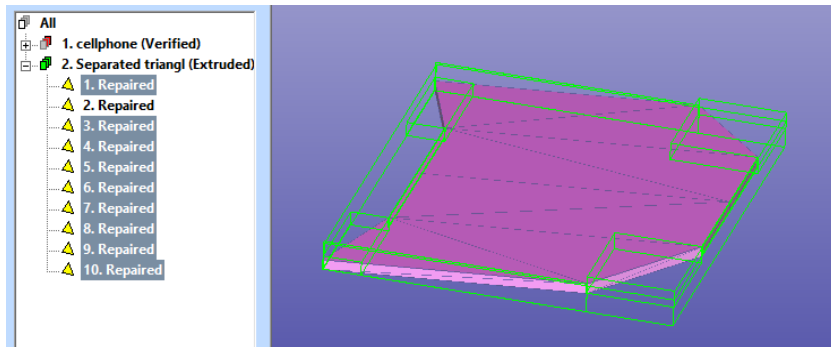

- **give Edit > Copy command**
- **select the 1. cellphone shell** from the Model Tree

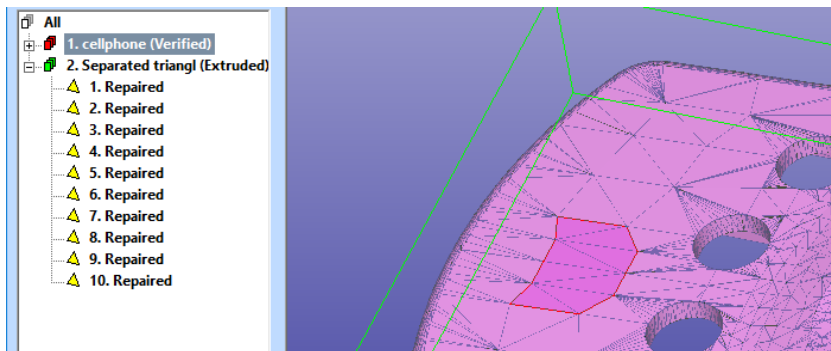

- **give Edit > Paste command**
- and you will have a correct *1. shell* in the model tree, too
- **hide the 2. Separated triangles shell** to see the corresponding blind hole on the cellphone surface

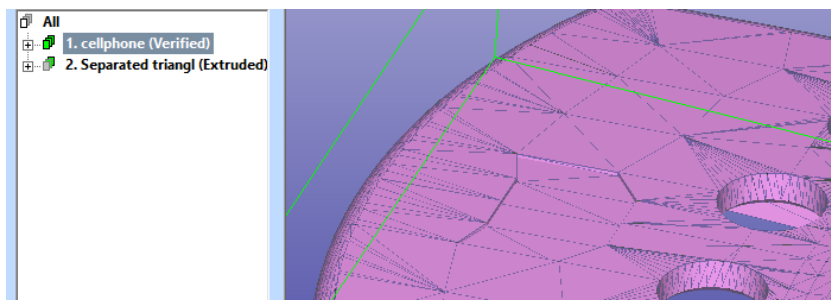

You can now rename and output the shells into separate STL files as was done in chapter **Outputting separate STL files.**

Chapter 8 – Using Offset to separate shells

In a manner similar to the Extrude command, the Modify Faceted > Offset command can be used to generate solid shells from separated surface areas. In this example we will first separate a surface area with Sketch Edge Line command and then separate and Offset it to solid shell.

Creating surfaces with Sketch Edge Line command

Let's start again with cellphone-repaired.3de model:

- **input the *cellphone-repaired.3de* model**, continue through the units and Operation Mode dialogs
- take a **view from -Z direction** (bottom)
- **select 1. Multiple selection (Repaired) shell** from the Model Tree
- **give command Fix Model > Edit Surfaces > Sketch Edge Line**; the system goes into *curve input* mode and surface edges are displayed:

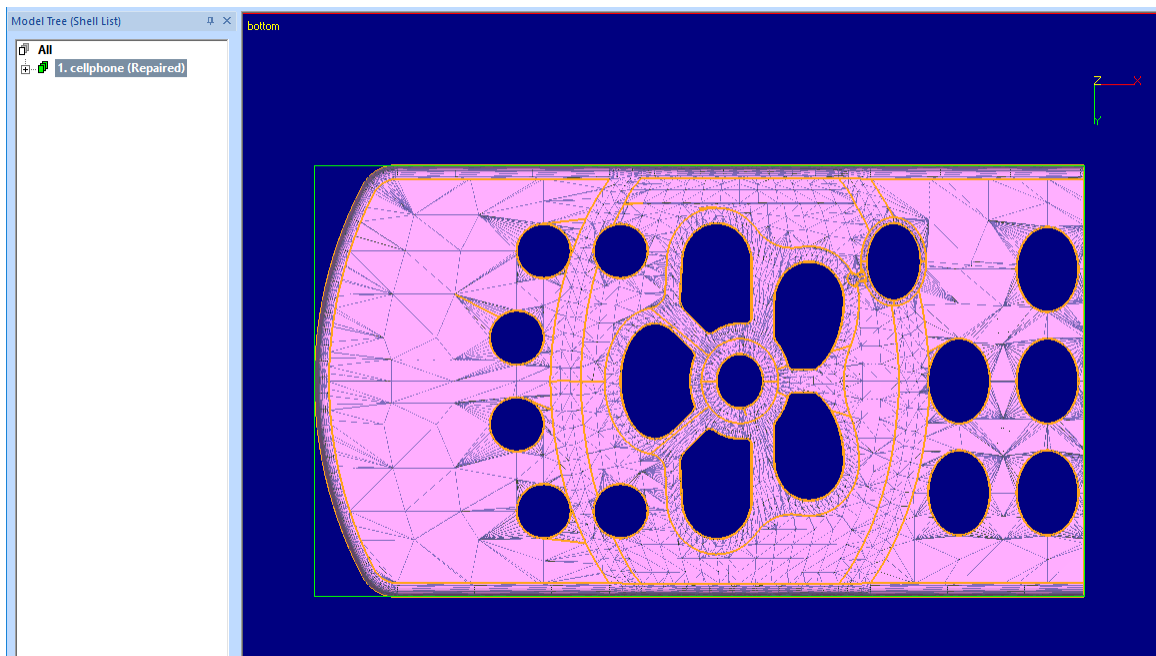

The system now waits for you to draw the new surface edge on the model:

- **add points on the model using the LMB**
- to quit adding points **select the first point again**, i.e. create a closed curve, as seen on the image below
- you may **select and reposition the points** until the curve shape is correct

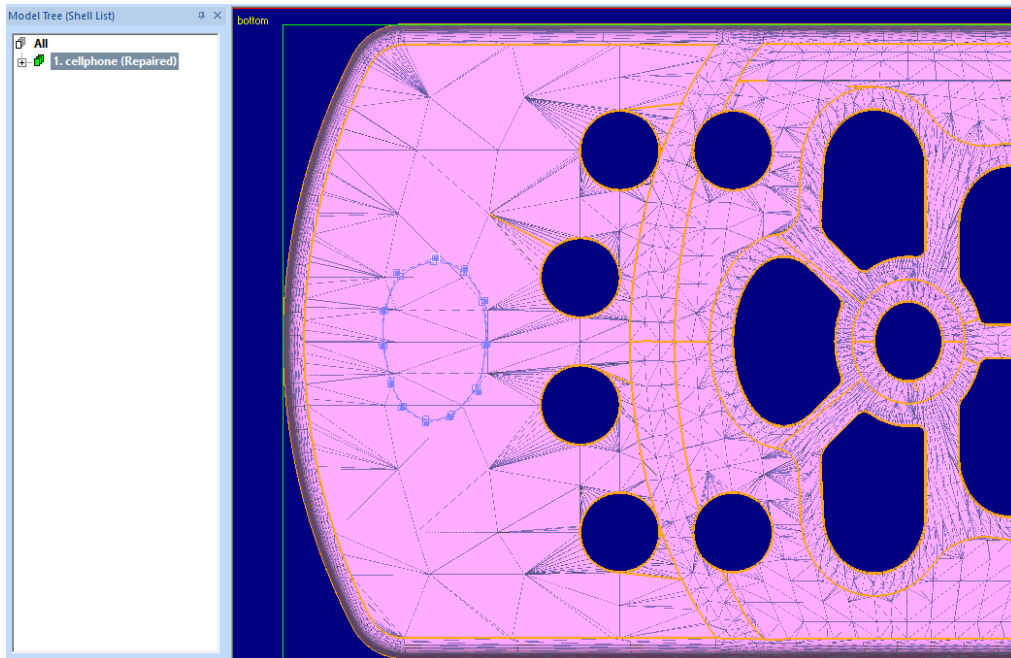

Now our surface edge line is ready and we will generate the new surface on top of the cellphone model.

- **press RMB to add the new surface** on the model
- **run Fix Model > Repair Shells** to fix minor errors in the model (and to avoid seeing hidden surface edges)
- and you will see the new surface:

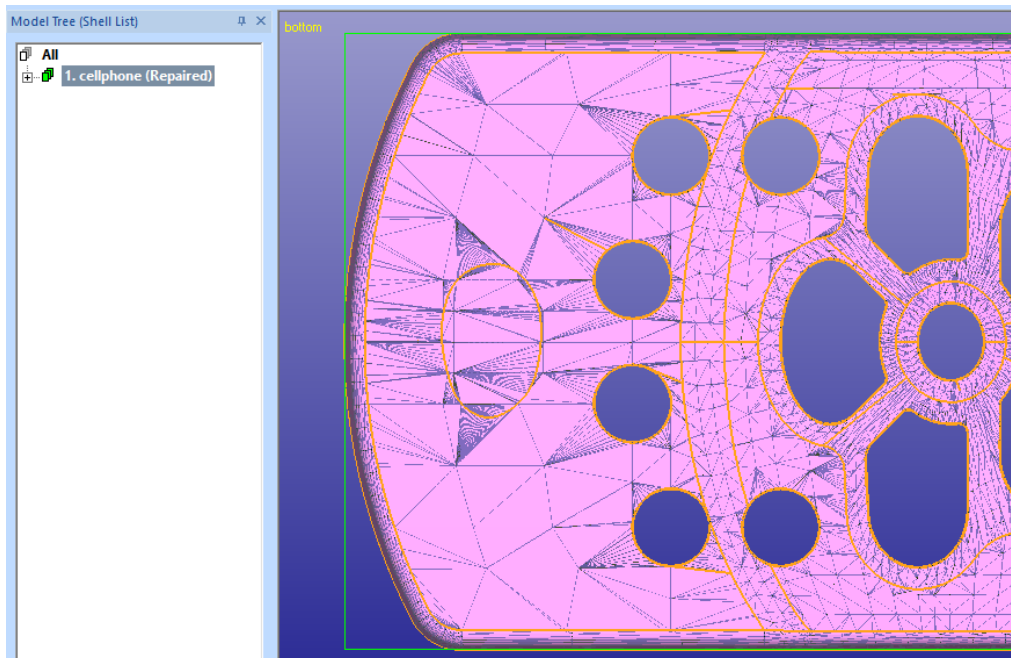

Separating the sketched surface

The new surface must be separated to a new shell before it can be Offset to solid model.

- **select the sketched surface** from the graphical area or from the Model Tree

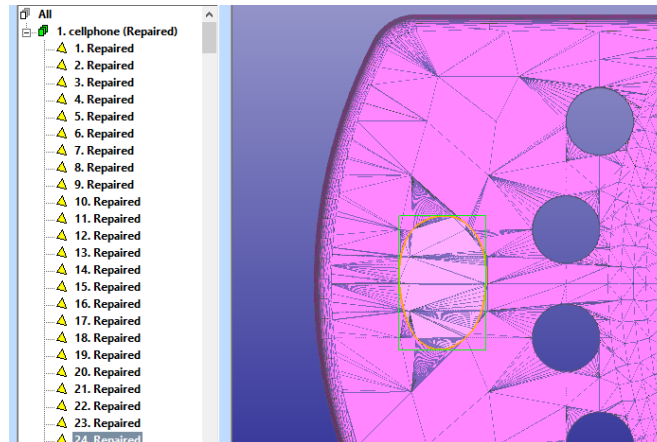

- **give Edit > Cut** command
- **select Model Tree root All**
- **give Edit > Paste** command
- **turn off surface edge line display** via *Fix Model > Edit Surfaces > Show Edge Lines* setting (or click the  button in the Tools window).

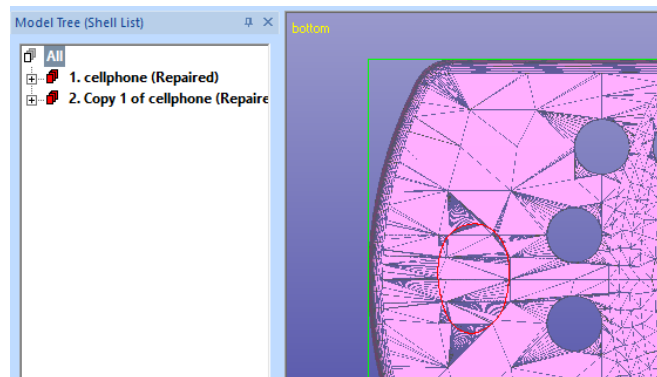

The Model Tree now contains two shells, one with the original cellphone mode without the delete sketched surface and the sketched surface in shell 2. *Copy 1 of cellphone (Repaired)* shell.

Using Offset command

We are now ready to use the Offset to generate the components for the new shells.

3Data Expert 16.0: Tutorial 3 - Separating Shells

- **select 2. Copy 1 of Multiple selection shell** from the Model Tree
- **give *Modify Faceted > Offset* command**
- if you get a warning about the model not being fully repaired **press Yes to continue**

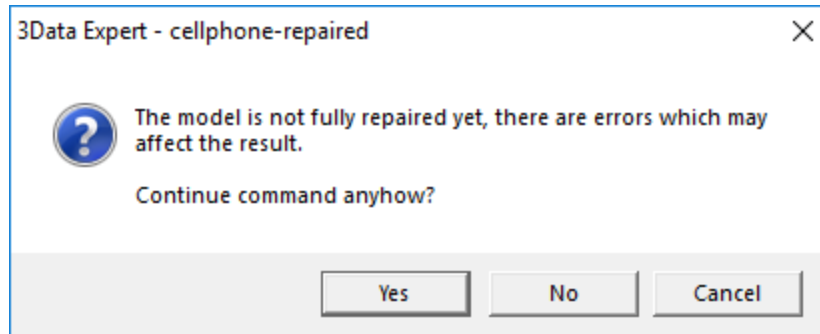

- **fill in the parameters given in the image below, especially *Result into original shell* must not be set!**

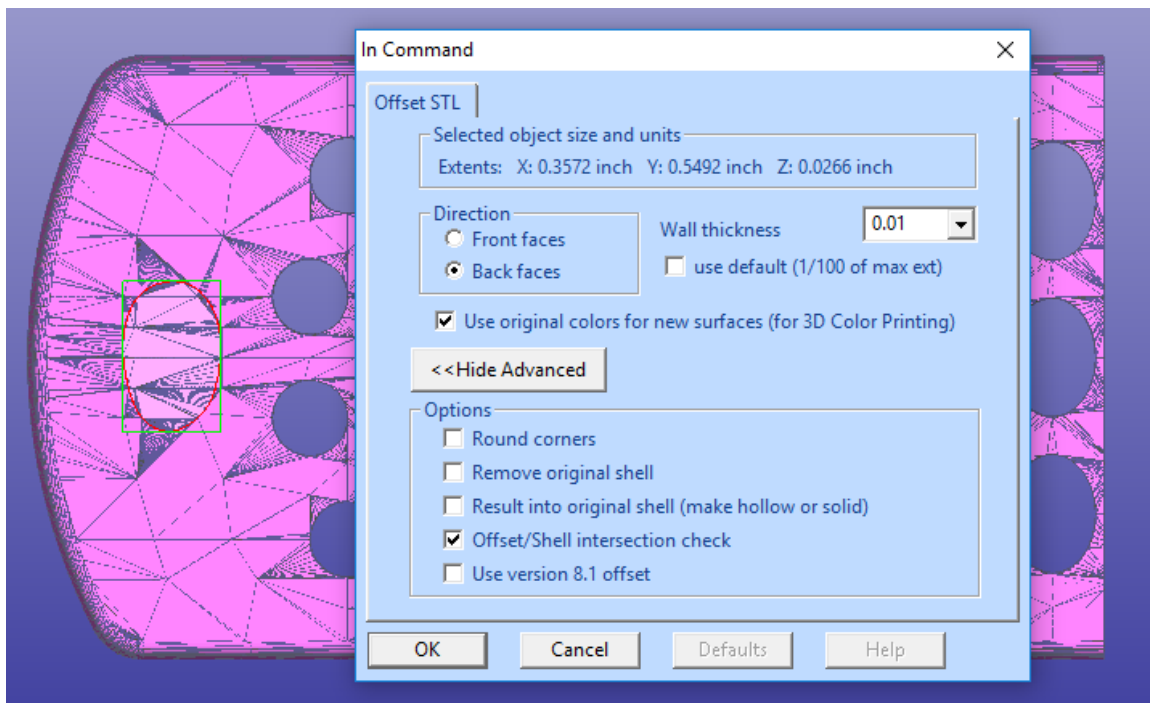

- **press OK** to create the offset
- **fit the Offset result 3. Copy 1. of Multiple (Offset)** to see the result

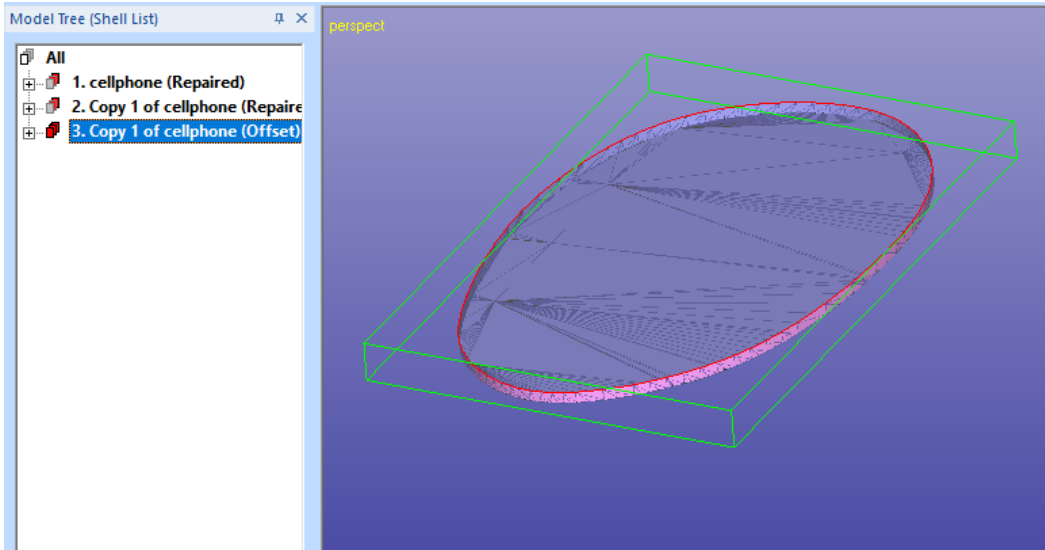

You now have all necessary parts in the Model Tree for creating the two solid shells. Do the following:

- **select the third shell 3. Copy 1 of Multiple (Offset)** in the Model Tree (the offset result)
- **give *Edit > Copy* command**
- **select the 1. Repaired surface** of the first shell 1. Multiple Selection (Repaired) in the Model Tree (original model)

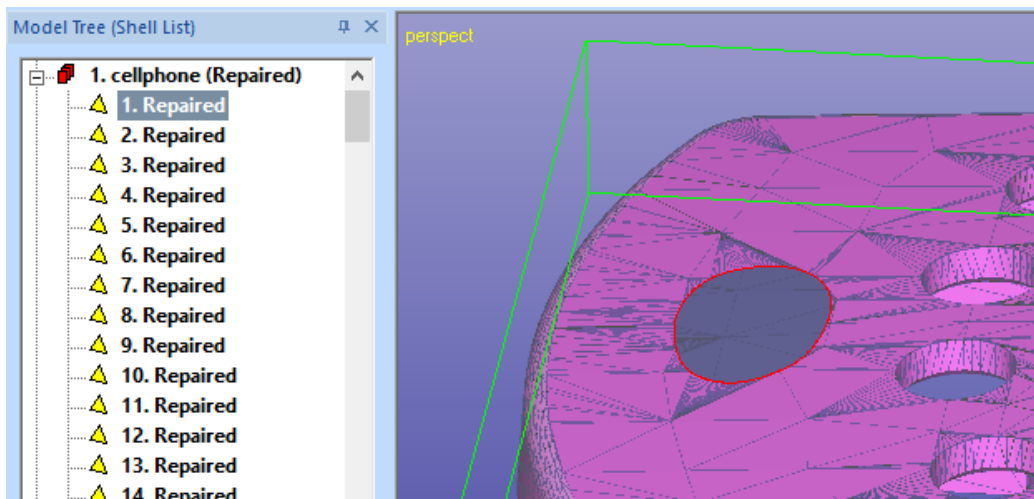

- **give *Edit > Paste* command** to add the copied Offset result to the shell
- you will see a correct 1. shell to appear in the Model Tree. The original shell now has the blind hole added to it.

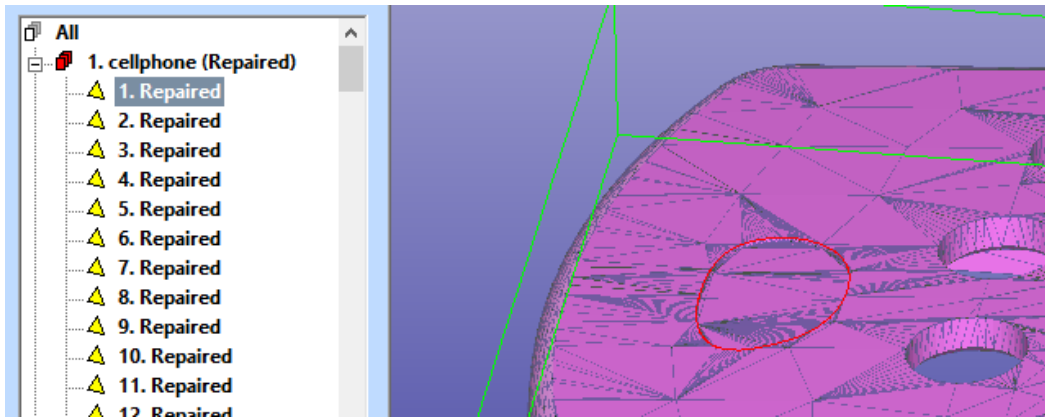

In case of errors in *1. cellphone (Repaired)*, please run *Fix Model > Repair Shells* command with default parameters on that, to get fully correct component.

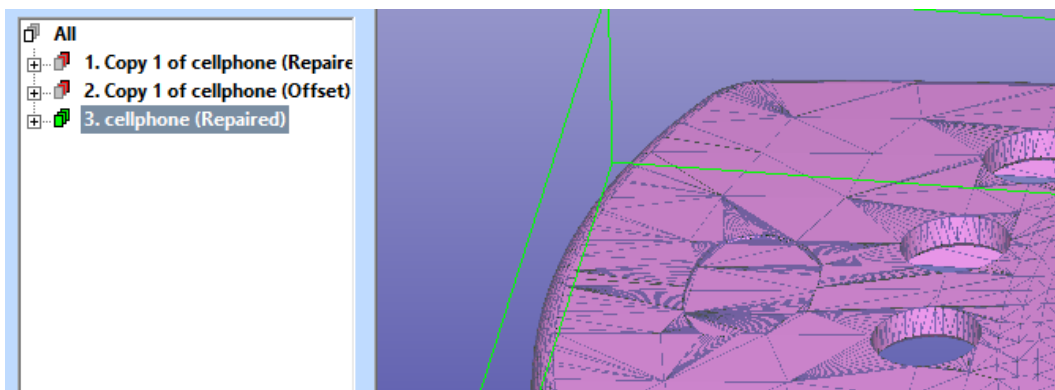

Now we need to join the two remaining red shells in the Model Tree into one shell to get correct solid shell. For example:

- **select the 2. Copy 1 of Multiple (Offset) shell**
- **give *Edit > Cut* command**

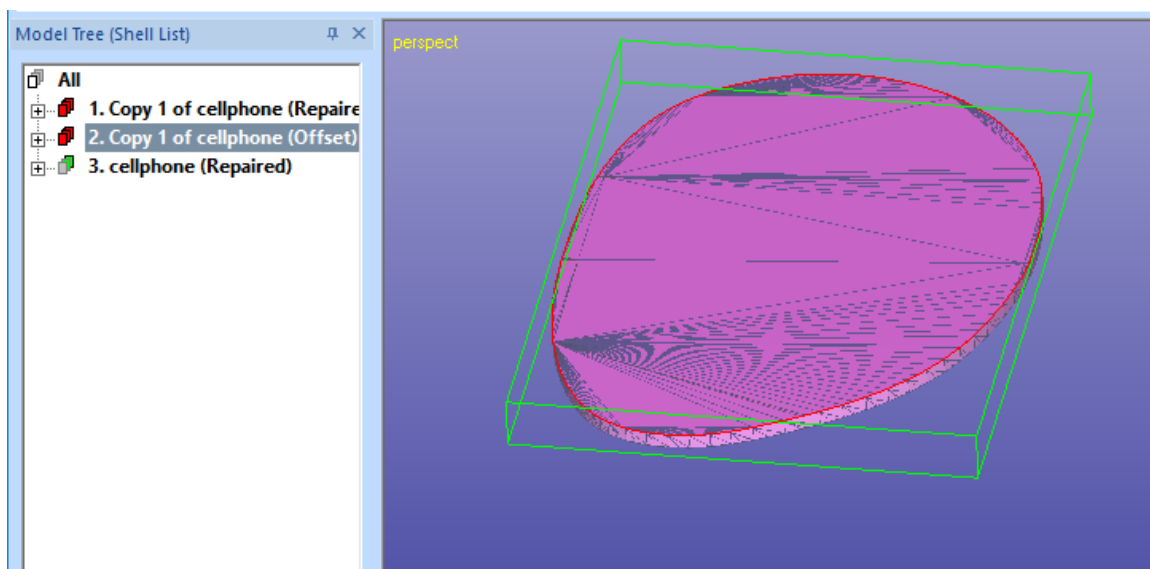

- select the first surface in the **1. Copy 1 of Multiple selection shell**
- give **Edit > Paste command** to paste the cut shell into the that shell

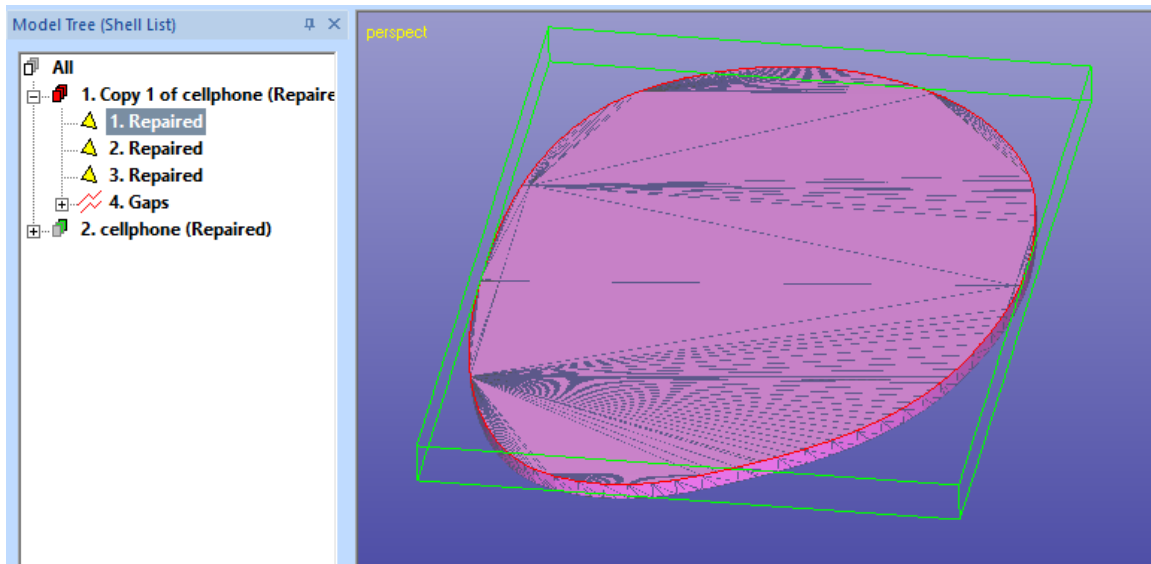

In case of errors in *1. Copy 1 of cellphone (Repaired)*, please run *Fix Model > Repair Shells* command with default parameters on that, to get fully correct component.

Now you will have the two solid shells in the Model Tree for output, please see chapter **Outputting separate STL files.**

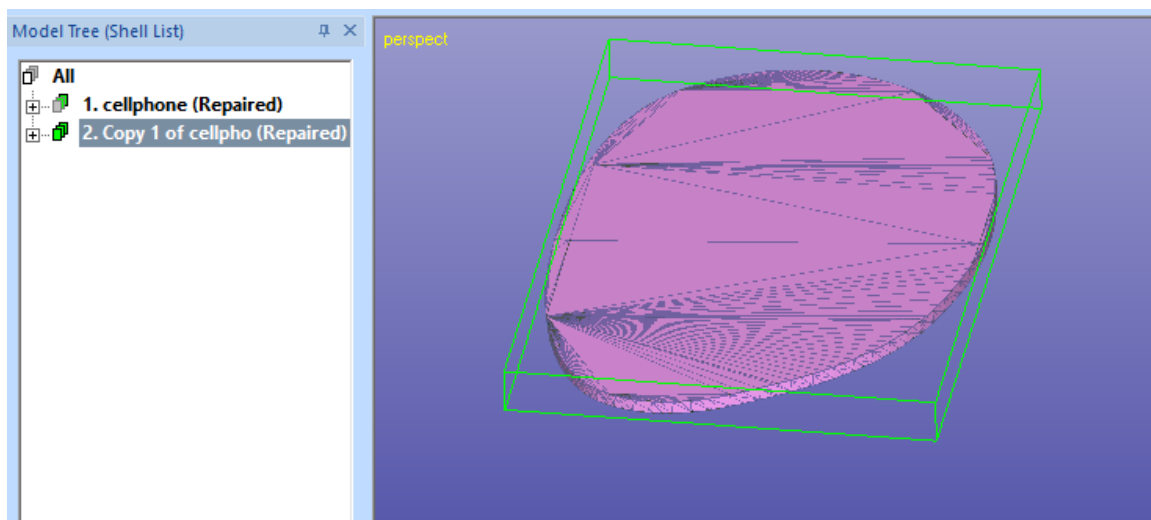

Selecting multiple surfaces for Offset or Extrude

Of course, it is possible to use the existing surfaces for separation and subsequent Offset or Extrude. For example, you may want to try to separate the surfaces around the keypad for separate shell creation.

First select the surfaces show in the image below (Ctrl + LMB):

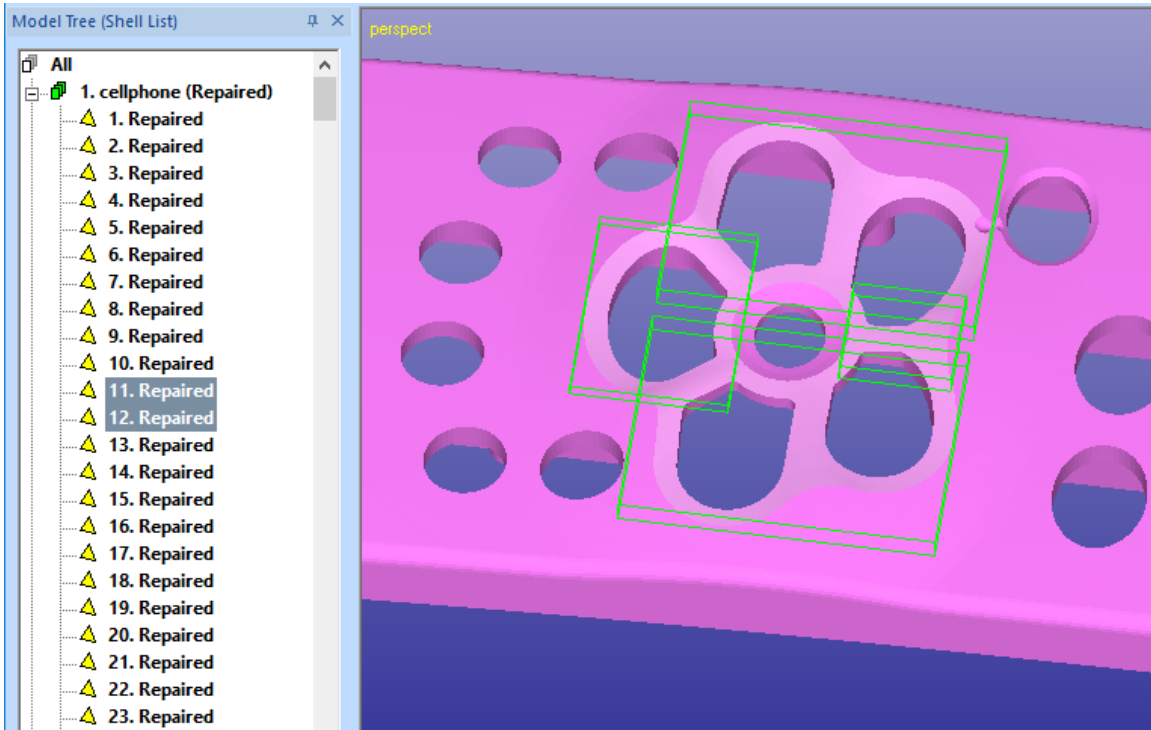

Then Cut and Paste them into Model Tree:

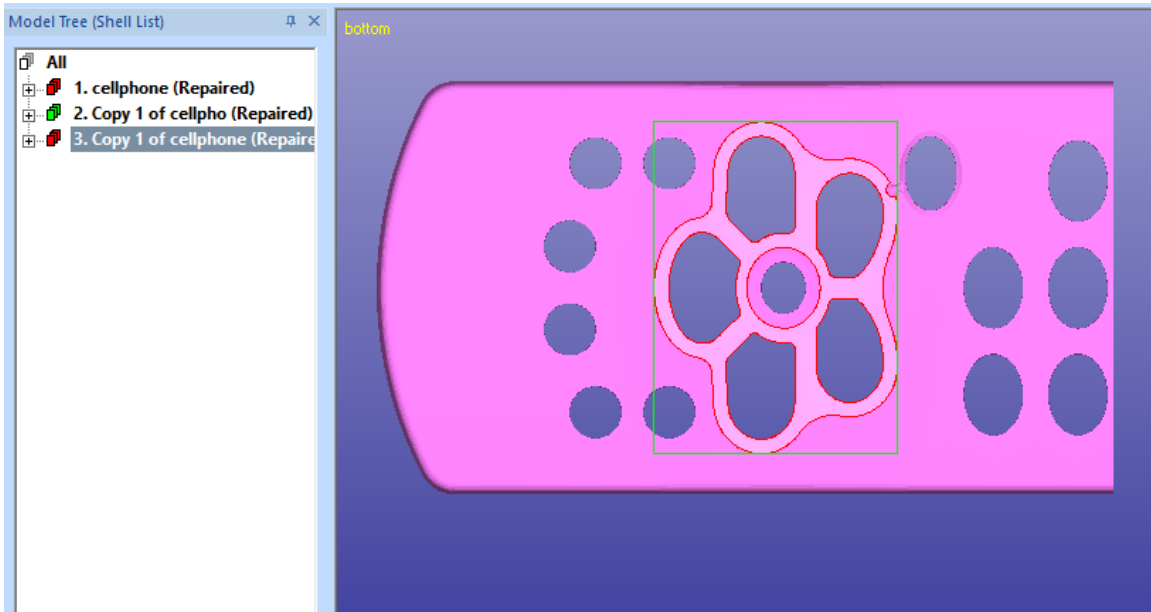

3Data Expert 16.0: Tutorial 3 - Separating Shells

Now you can use Offset to the inside direction again (Back faces, result not in the same shell as the offset shell):

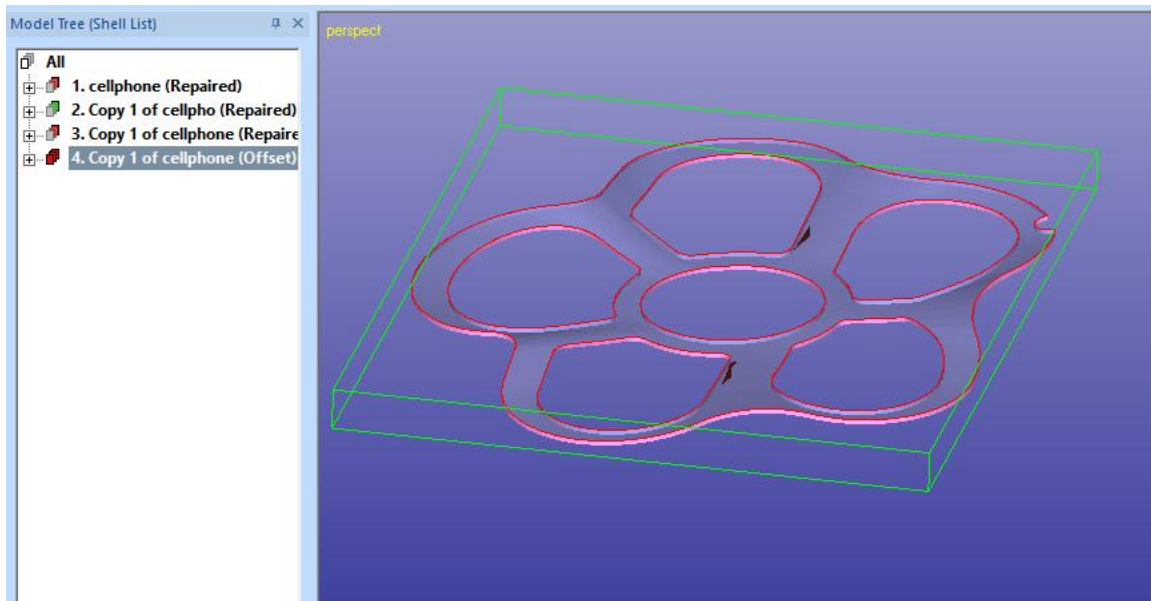
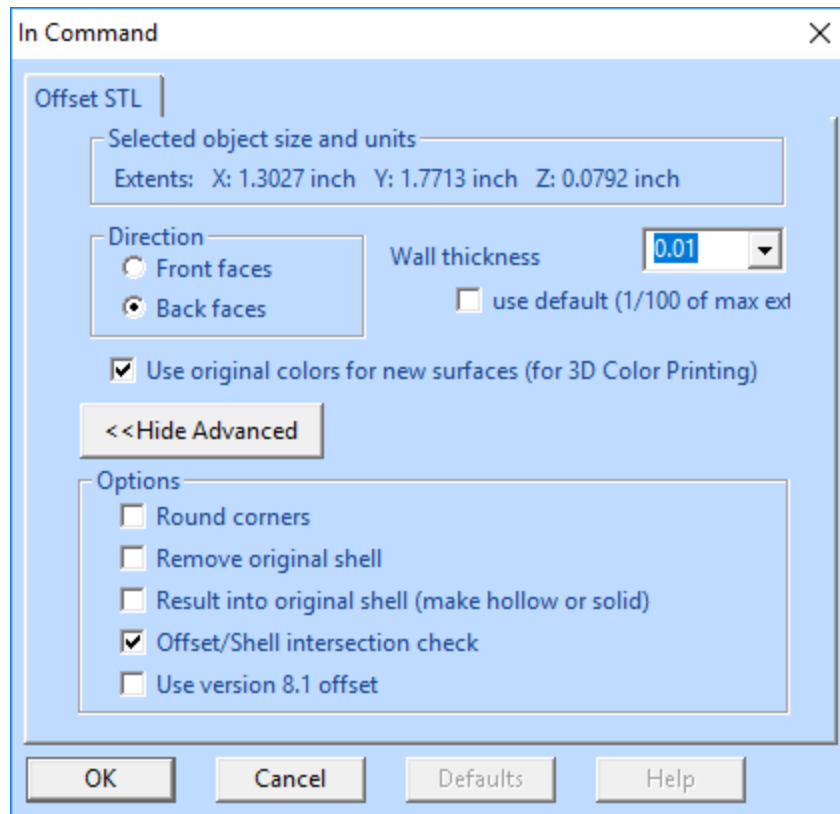

Then make the two shells solid again by Copying the Offset result to the original shell and then connect the separated shell and the offset shell into a solid shell:

3Data Expert 16.0: Tutorial 3 - Separating Shells

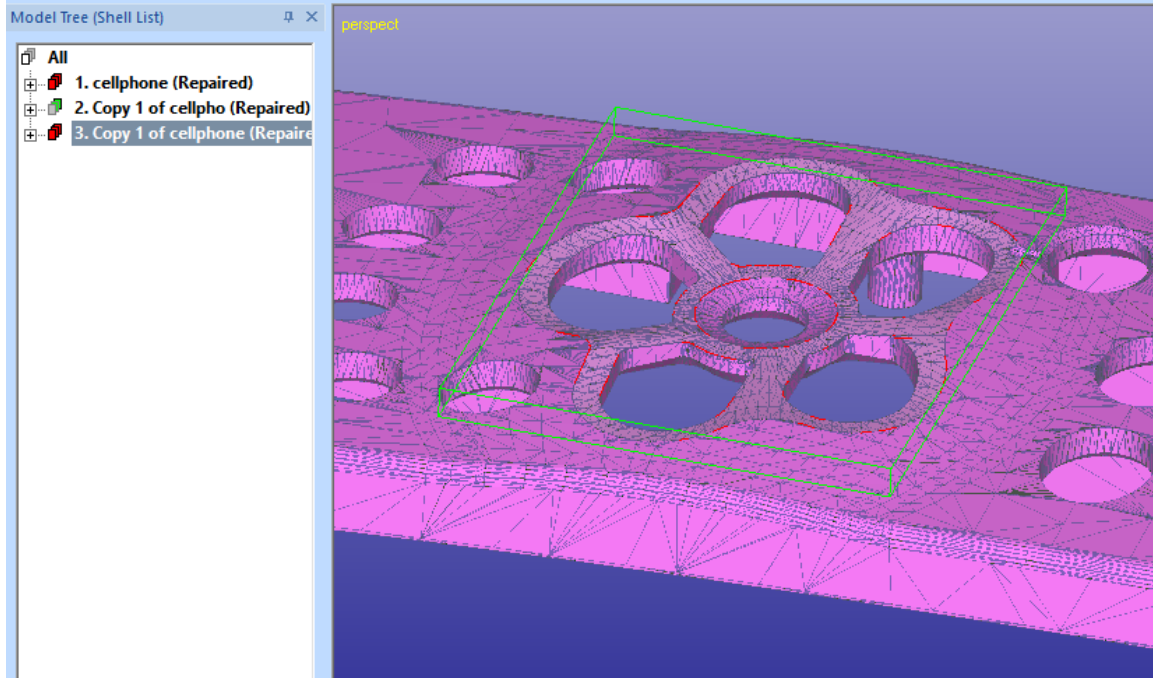

There are some errors in the generated shells, run them both through the Fix Model > Repair Shells command. The separated parts turn out to be correct but there are still some errors in the original cellphone model. These errors are marked green with a warning in the Model Tree:



The errors are caused by some zero volume walls and intersecting triangles in them. These are created when the Offset result is added to the original model. The Offset direction follows the vertical walls of the holes in the original model:

By default, these errors are considered insignificant. If, in your 3D printing environment, it can be a problem to create separate shells at areas where surfaces

meet perpendicularly at the extrude area edges, then you can change the classification in Fix Model > Define Warnings. For the evaluation, you can check the result of this chapter: *cellphone-offset-separated.3de* in the *Tutorials\GeomFiles* folder.

Conclusions

This *Separating Shells* document has given you the skills to separate shells from a solid STL model for systems with digital material properties or capable to produce parts with multiple colors.