

DeskArtes

3Data Expert 16.0

Tutorial 4 - Generating Supports for AM

First Edition

“3Data Expert 16.0: Tutorial 4 - Generating Supports for AM”.

February 2026

Copyright

© 2026 DESKARTES. All rights reserved.

DESKARTES reserves the right to revise this publication and to make changes from time to time without the obligation to notify any person of such revisions and changes.

Trademarks

The DESKARTES name and the logo are trademarks of DESKARTES Oy. Other brand and product names are trademarks and registered trademarks of their respective owners.

Contact Address

DESKARTES OY

Takomotie 8

FIN-00380 HELSINKI

Finland

<https://www.deskartes.com>

Table of Contents

FOREWORD.....	4
LESSON 1 – LEARNING THE GRAPHICAL USER INTERFACE.....	6
<i>Generating supports automatically.....</i>	6
<i>Examining the first supports</i>	9
<i>Optimizing parameters for a selected support area</i>	12
LESSON 2 – EDITING SUPPORT GEOMETRIES MANUALLY	21
<i>Adding supports manually</i>	21
<i>Deleting supports manually.....</i>	29
<i>In this exercise we will delete a whole support area as well as details inside another support area.</i>	29
<i>Applying Arch command to support geometry.....</i>	33
<i>Adding Side support.....</i>	36
<i>Adding Tree support</i>	40
LESSON 3 - LEARNING SUPPORT PARAMETERS.....	48
<i>Opening and saving support parameter files</i>	48
<i>Editing Common support parameters</i>	50
<i>Editing Web support parameters</i>	55
<i>Editing Chain support parameters.....</i>	59
<i>Editing Point support parameters.....</i>	64
<i>Generating Tube supports.....</i>	67
<i>Compact parameters dialog.....</i>	70
<i>Generic Support improvements with version 14.0</i>	71
LESSON 4 - OUTPUTTING AND SLICING SUPPORTS FOR AM.....	74
<i>Saving supports STL file</i>	74
<i>Saving support and part slices</i>	75
<i>Slicing supports and parts into one file.....</i>	79
<i>Previewing Slice data</i>	82
LESSON 5 – ADDITIONAL TOOLS FOR SUPPORT GENERATION	84
<i>Center of Gravity calculation</i>	84
LESSON 6 – CONNECT TOOL	85
<i>Connect Tool command</i>	85
LESSON 7 – SAND SUPPORTS	90
<i>Sand Support generation.....</i>	90

Foreword

The *3Data Expert 16.0: Tutorial 4 - Generating Supports for AM* document provides a tutorial to support generation module in 3Data Expert 16.0 and later versions. The *Generic Support* command enables the generation of supports for various AM processes, like metal, stereolithography and DLP systems.

Additionally, the last lesson shows how to generate supports for sand-based systems.

There is a wide variety of support geometries you can generate with the 3Data Expert support generation commands. Supports can be either open or solid (e.g. with volume). Solid supports can be generated for heat dissipation and warpage prevention with metal-based AM processes. Open and delicate support structures can be generated for DLP or stereolithography parts. Web, Chain and Point supports can be used to support different areas in the part, like large downfacing surfaces, sharp edges and local minimum points in the part. Supports can even be converted to small tubes for special medical model manufacturing, like tooth implants. Side supports and Arch supports can be used to prevent part movement during the build or to avoid hitting part surface area below the areas needing supports. Tree supports can be generated for parts with special geometries, like rings and other jewelry products in metal. Supports can be generated both fully automatically and optimized with manual commands.

To get most of the tutorial lessons you should go through the examples with 3Data Expert 16.0. If no hard copy of the tutorial is available, we recommend you open 3Data Expert and tutorial document side by side on the computer screen:

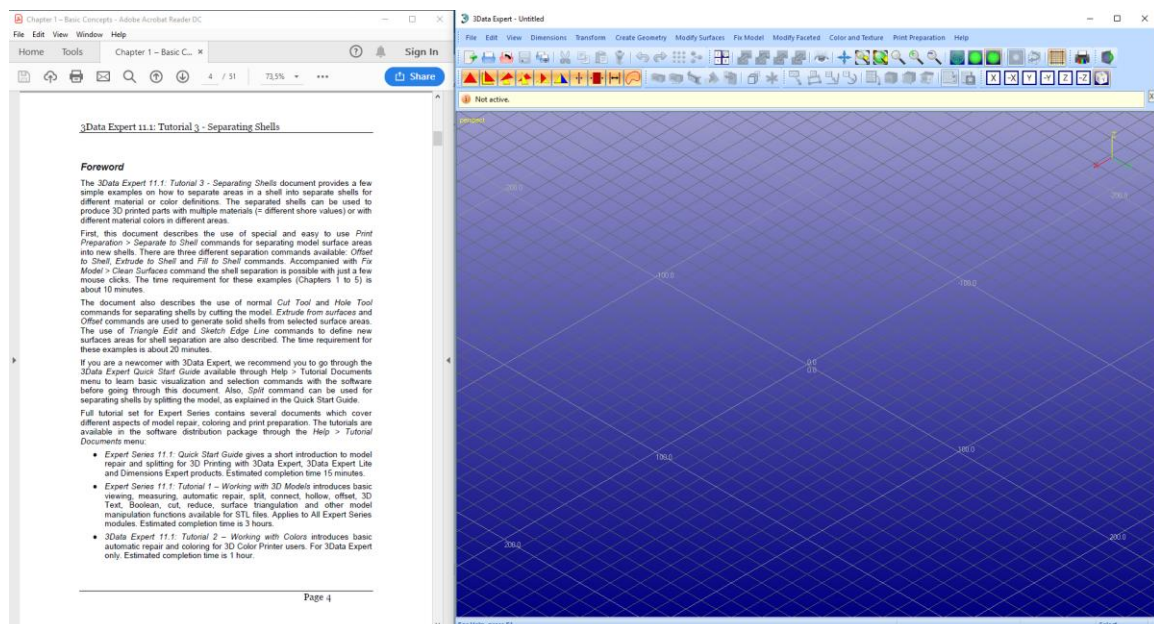

3Data Expert 16.0: Tutorial 4 - Generating Supports for AM

You will need a licensed version of 3Data Expert for the lessons. The functionality described in this tutorial can be tested with DeskArtes 3Data Expert software release version 14.0.0.5 or later (*Help > About 3Data Expert*).

You can also use DeskArtes 3Data Expert to generate supports for sand process parts. More on Sand Support command can be found in the application Help and Tutorial 4 - Generating Supports for AM.

Full tutorial set for 3Data Expert contains several documents which cover different aspects of model repair, coloring and print preparation. The tutorials are available in the software distribution package through the *Help > Tutorial Documents* menu:

- *3Data Expert 16.0: Quick Start Guide* gives a short introduction to model repair and splitting for 3D Printing with 3Data Expert. Estimated completion time 15 minutes.
- *3Data Expert 16.0: Tutorial 1 - Working with 3D Models* introduces basic viewing, measuring, automatic repair, split, connect, hollow, offset, 3D Text, Boolean, cut, reduce, 3D nesting, surface triangulation and other model manipulation functions available for STL files. Estimated completion time is 3 hours.
- *3Data Expert 16.0: Tutorial 2 - Working with Colors* introduces basic automatic repair and coloring for 3D Color Printer users. For 3Data Expert Base, Lite and Color. Estimated completion time is 1 hour.
- *3Data Expert 16.0: Tutorial 3 - Separating Shells* describes the use of Shell Separation commands in 3Data Expert. These commands enable separating a part into several shells for different material (shore value) or color definitions in a single part. For 3Data Expert Base only. Estimated completion time is 30 minutes.
- *3Data Expert 16.0: Tutorial 4 - Generating Supports for AM* explains the use of new Generic Supports command and Sand Supports command. The support generator can be used to generate supports for DLP, metal, stereolithography and sand-based processes. Adding extra connectors to prevent parts from warping and bending during the build is explained. Also, new slicing, slice preview and slice filling is demonstrated. Estimated completion time 1 hour.
- *3Data Expert 16.0: STL and VRML repair examples* document includes more advanced model repair operations with 3Data Expert. Estimated completion time with 3Data Expert 2 hours.

The tutorial documents and the geometry files for the tutorial examples are found in the *Tutorials* folder and its sub-folders (*GeomFiles*, *Tutorial 1*, *Tutorial 2*, etc.) in the 3Data Expert installation directory.

Lesson 1 – Learning the Graphical User Interface

The Generic Support command is operated through a set of toolbars. The toolbars allow both generating the supports automatically based on predefined parameter files as well as manual editing of supports for improved surface quality or increased robustness of the build.

Generating supports automatically

With this example we will just generate the supports using the automatic support generation process: We select the predefined support parameter file and generate the supports in “black box” mode.

The support generation is started by inputting a file needing supports into the Model Tree. We will first

- **open a test file *supp-demo1.3de*** into 3Data Expert with *File Open* command. The file is stored in the *tutorials/GeomFiles* directory under the 3Data Expert installation in Program Files directory.
- **accept** the proposed units by **pressing OK**
- **press Print** in the Operation Mode window

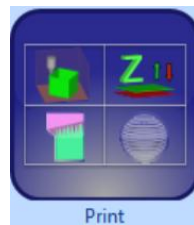

- you will see the model stored in the Model Tree

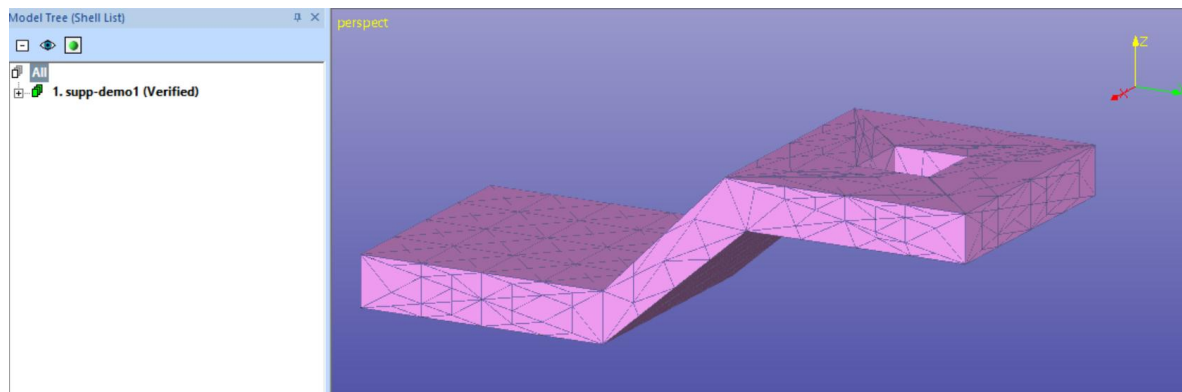

The example file contains a model with hole, surfaces with different surface angles as well as some local minima. The support generation will create sufficient support at the flat areas, around area edges as well as below the local minimum points.

Let's now start generating supports to the example model:

- **select the model** in the Model Tree

- Give the command **Print Preparation > Supports > Generic Support** or press Supports button in the Print Preparation Tab



A Print Configuration setup has been automatically loaded and contains the default support parameters for your environment:

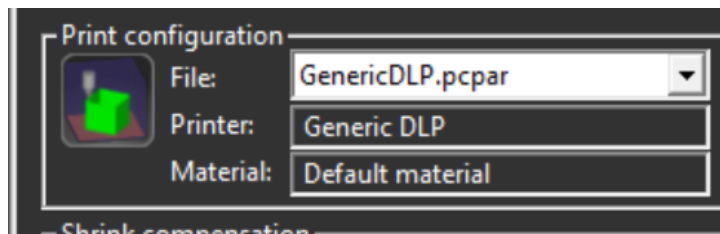

For more information about the Print Configuration and workspace, please refer to lesson Positioning Parts in the Tutorial 1 - Working with 3D Models document. In this tutorial we will specifically study the support structure generation parameters.

The Graphical user interface toolbars for support generation appears:

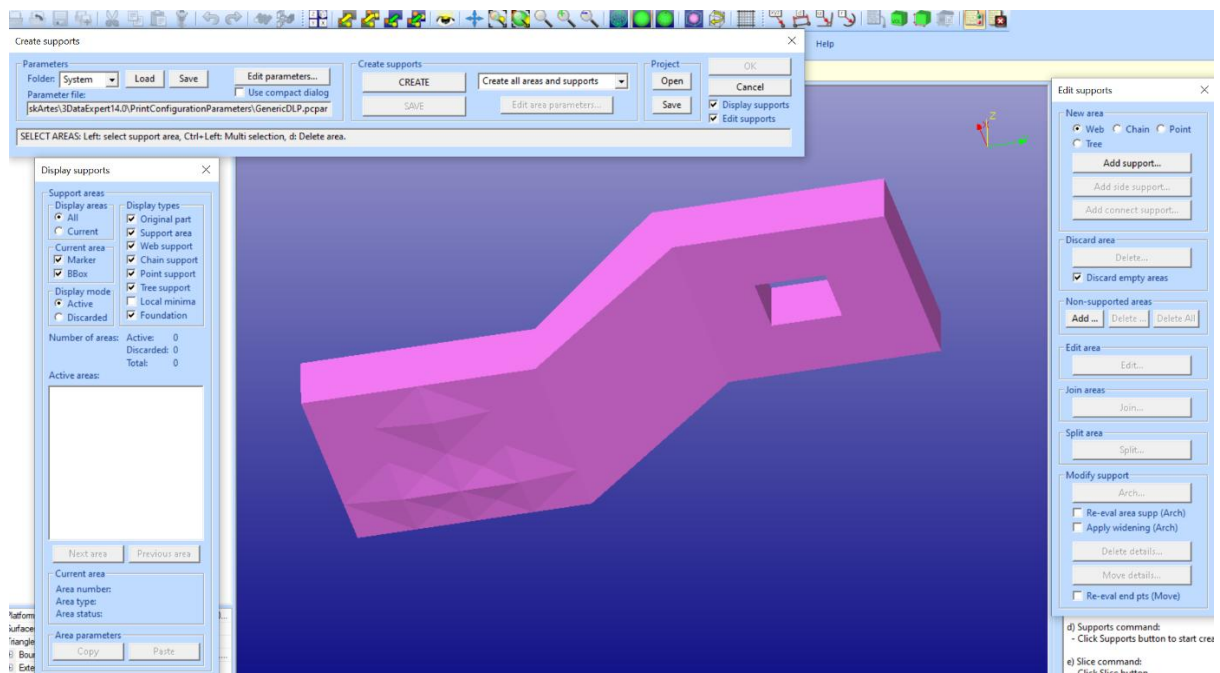

We recommend that you position the different support generator toolbars as given in the image above. This will leave the Viewing Toolbar and especially the Viewing Planes Toolbar (X, Y, Z views) visible.

There are three toolbars: *Create supports*, *Display supports* and *Edit supports*. The functions are divided between the different toolbars according to their names.

3Data Expert 16.0: Tutorial 4 - Generating Supports for AM

Anyhow, this time we will just generate the supports using the automatic support generation. The supports are generated according to the parameters given in the *Print Configuration*. Then

- **Press Create button** in the Create supports toolbar to create all areas and supports for the plate model

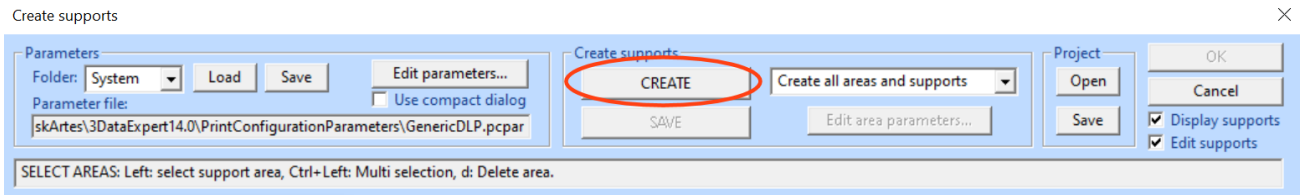

First the command checks that all parameters are consistent with each other. **Press Ok or Yes** to the appearing confirmation and report dialogs (if any appear) to continue the support generation. If necessary, the support parameters are adjusted by the system to ensure concise STL structure generation.

After a while the supports are generate and appear in the graphics area.

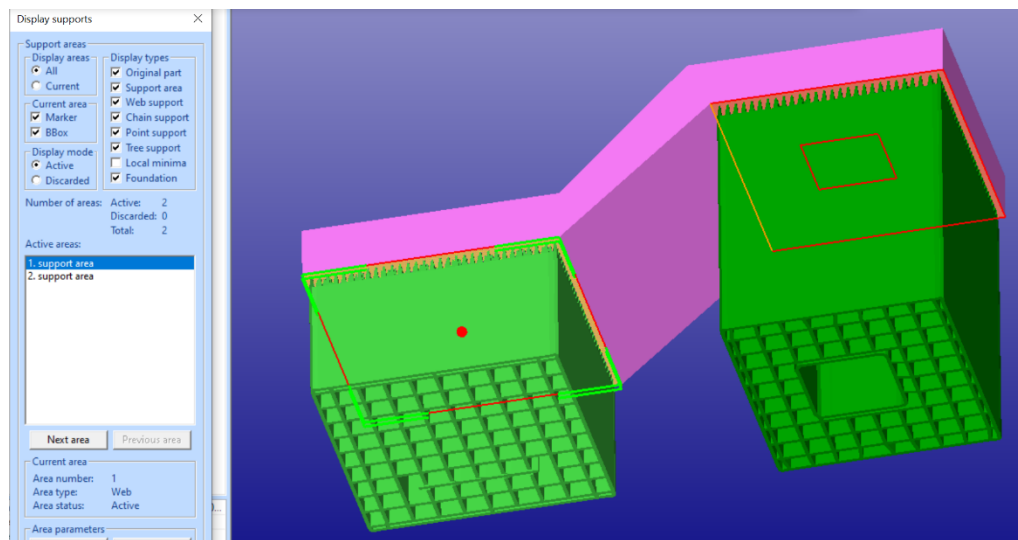

You can investigate the supports visually with the *middle mouse rotation*, *middle mouse zoom* and other graphical viewing commands. The red edge line around a supported area means that this specific edge is not supported by the part itself, while orange edges are supported by the part. Depending on the supported/not supported edge, the support itself can be further from or nearer to the given edge.

The support area with lighter green color and marked with the red point is currently selected as active area in the support area list (1. support area).

Finally, we store the generated supports in the Model Tree.

- Press **OK** button in the **Create supports** toolbar to store the supports into the Model Tree.

After a while the supports are verified and stored in the Model Tree:

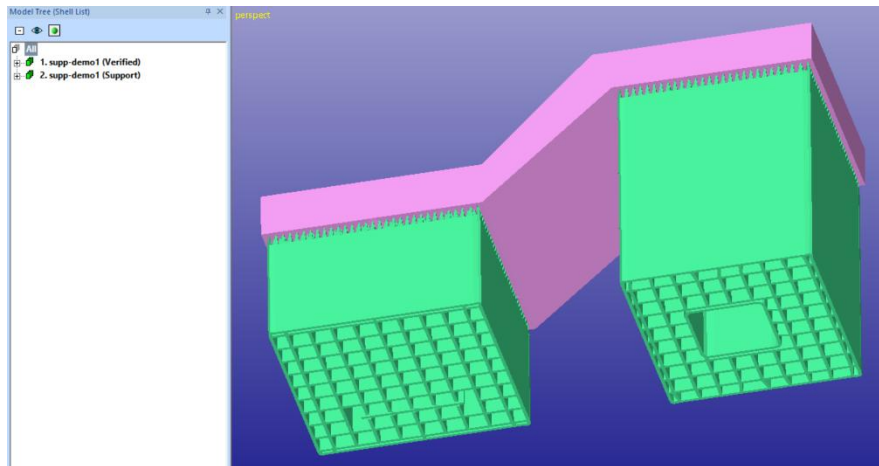

Examining the first supports

The generated supports have several properties which are important for correct build of a part with an AM system. The selected parameter set produced supports with the following properties:

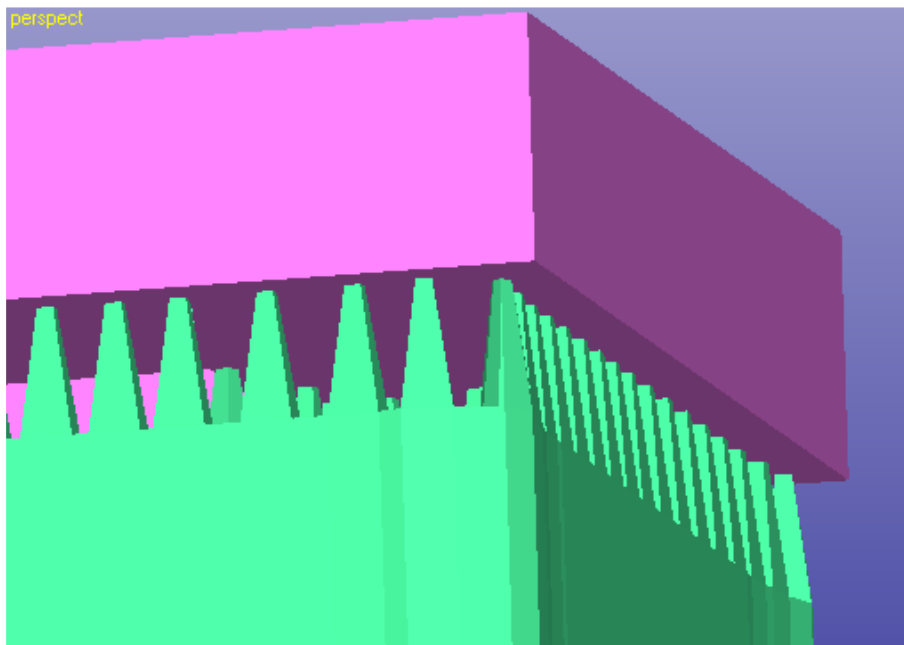

- The supports are solid. This allows to use supports for any AM system (DLP, metal, stereolithography) by providing enough strength and/or heat dissipation from the part with metal processes. Open (zero thickness) support structures can also be generated by simply modifying a parameter via the parameter editor (to be shown late).

3Data Expert 16.0: Tutorial 4 - Generating Supports for AM

- The supports are connected to the part via teeth. This makes it easier to remove the supports from the part after manufacturing. The user has full control to the teeth size via the parameter editor. Additionally, dovetail shape can be generated on the teeth for controlling the breaking point for the teeth accurately.
- The supports follow the profiles of the supported areas. This prevents delamination at the support area edges with minimum amount of supports
- The supports are only generated to areas requiring supports. With this example, we only generate supports to surfaces with smaller than the 22-degree threshold angle to the vertical plane. The diagonal area in the middle has a 40-degree angle with the horizontal plane, thus not needing supports:

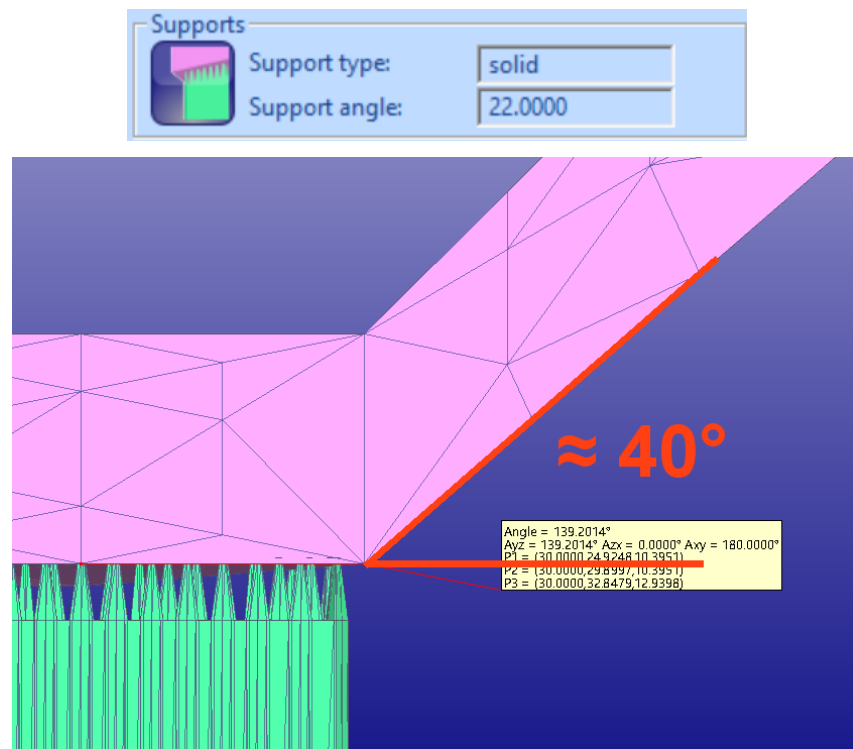

- The support teeth are generated under the local minima. In the original parts some areas of the down facing surfaces were slightly lower than the surrounding down facing area (left in the picture below). In the final result we can see that tooth tips are located exactly below the local minima (in red ellipses below right, clipping applied). It is essential to support the part from the lowest points to guarantee correct manufacturing of the part.

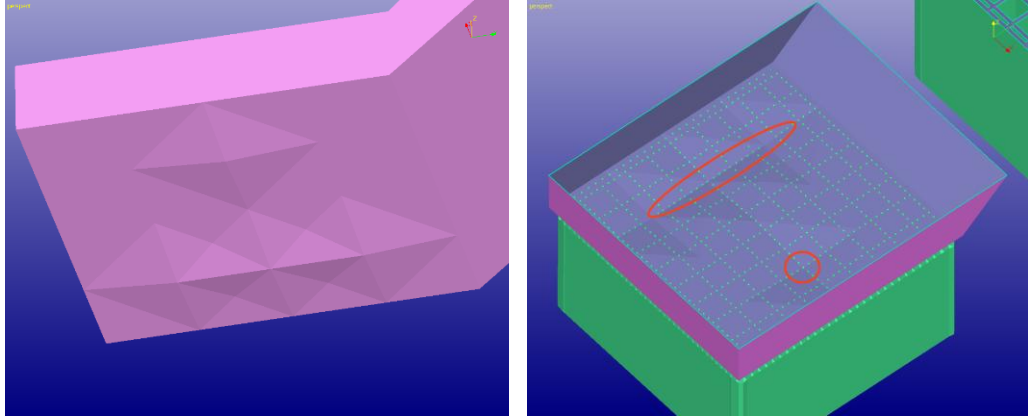

- The supports are generated from the part to the vat bottom $Z = 0$ level. You should always leave sufficient room between the part and the vat bottom for the supports. Also, the part must be in the positive space when supports are generated. If necessary, you can use *Print Preparation > Move to Platform > Move positive* command to position the part correctly before support generation:

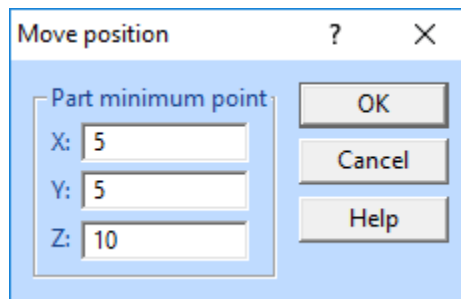

The supports for *supp-demo1* can now be outputted for AM or sliced and then send directly for AM. These steps are described in the last *Chapter 6. Outputting and Slicing Supports for AM.*

Additionally, supports

- will separate from vertical areas with user given tolerance. This will ensure better surface quality
- teeth can also be generated on the bottom of the support when an overhang area needs to be supported from the part surface below the overhang area. This will also improve surface quality and make support removal easier:

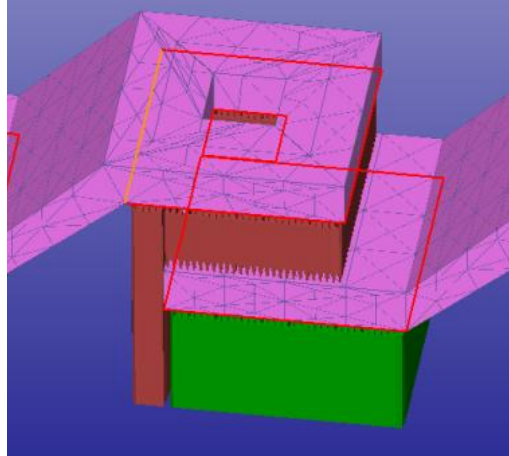

In the example above the support area hitting the part underneath is shown red during the support generation mode. Sometimes you can try to avoid hitting the part below by using the *Edit supports* dialog *Arch* command. With *Arch* command you can manually bend the supports to avoid hitting the part below.

Optimizing parameters for a selected support area

The normal process for support generation is described above where the user automatically generates the supports based on the parameters defined in the Print Configuration. However, there may be situations where automatic support generation does not generate the optimum result. Some areas may require removal of extra support, supports for some area may require different solid thickness, another area may need to be split into separate areas and some model edges may require extra support. This and more can be achieved by using the interactive tools available with Generic support command toolbars.

In the next example we will change the parameters for a specific area and then regenerate the area supports only. Once again,

- **open the *supp-demo1.3de* model and**
- **press *Create* button in *Create supports* group**

The supports are now visible in the graphics area.

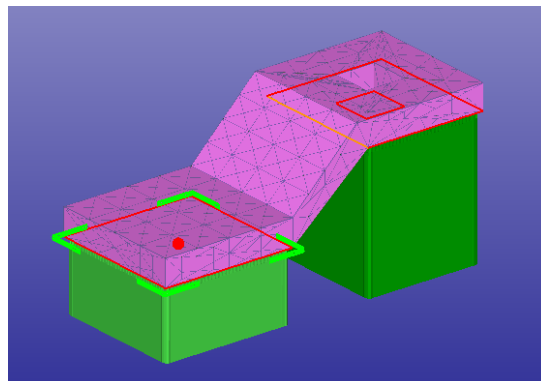

3Data Expert 16.0: Tutorial 4 - Generating Supports for AM

We will now take a quick look at the different display operations for the *Support areas*. The *Display areas* group will allow you to show either *All* areas or the *Current* area. *All* areas is the default value and by selecting the *Current* area you will see only the area which is selected in the support area list. Below we have

- **selected the *Current* area display**
- **then select the *first are* in the area list.**

Only the first area is now displayed on the graphics area:

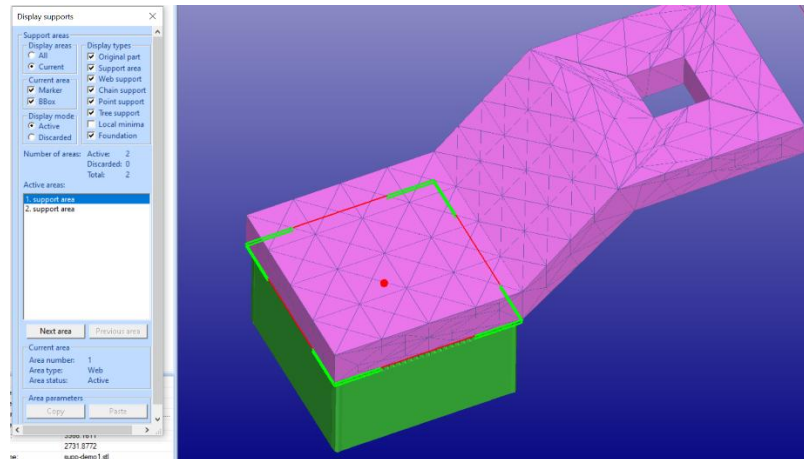

- **select *All* areas again**

The *Current area* group lets you select if the current area is shown with red point marker and/or bounding box corners.

The *Display mode* group allows to show either *Active* areas or *Discarded* areas. *Discarded* areas are support areas which do not have any support, or which have been deleted by the user.

The next group, *Display types*, allows you to set on display of different objects in the support generation. For example, you may only want to see the supported areas and supports, then

- **click *Off* the *Original part* display type selection:**

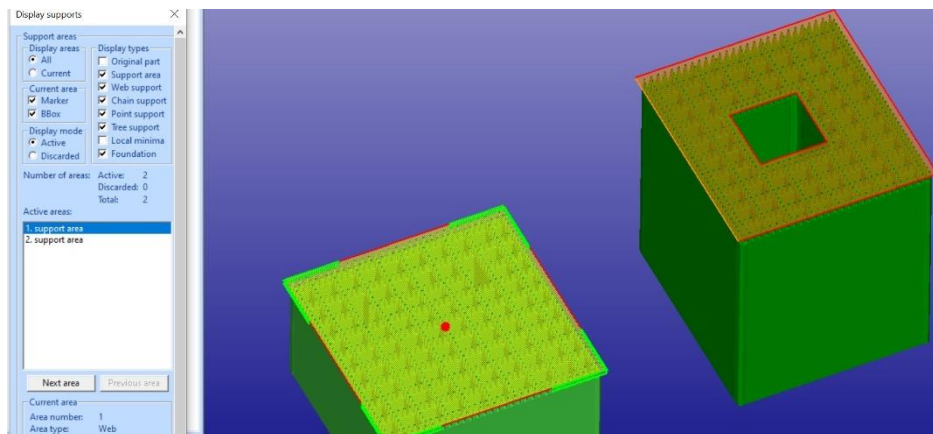

3Data Expert 16.0: Tutorial 4 - Generating Supports for AM

You will see the support area triangles with orange hue and the area edges with red edge polygon.

Or you may only want to see the supports, then

- **tick Off the *Support area* selection:**

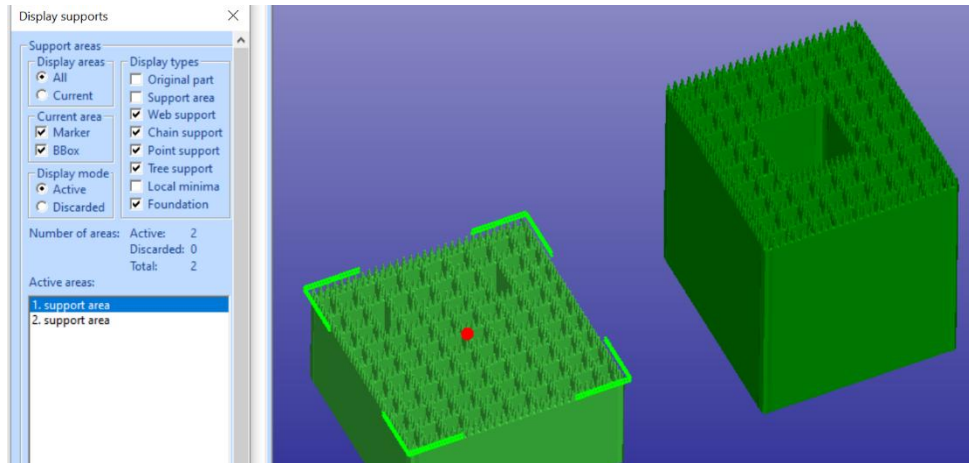

Furthermore, you can only select to show specific support types, like *Web*, *Chain* or *Point* supports. We do not have an example of the Chain and Point types available now, but different visualization types will allow you to effectively investigate, edit and select areas for optimal support generation.

Now, let's select the second area from the support area list and change the parameters for that area.

- **Turn On all *Display types* and**
- **select *Display area* selection *Current*. Then**
- **select *2. support area* in the list with the *LMB* (left mouse button):**

We will now see the part and the supports for the second area in the graphics area.

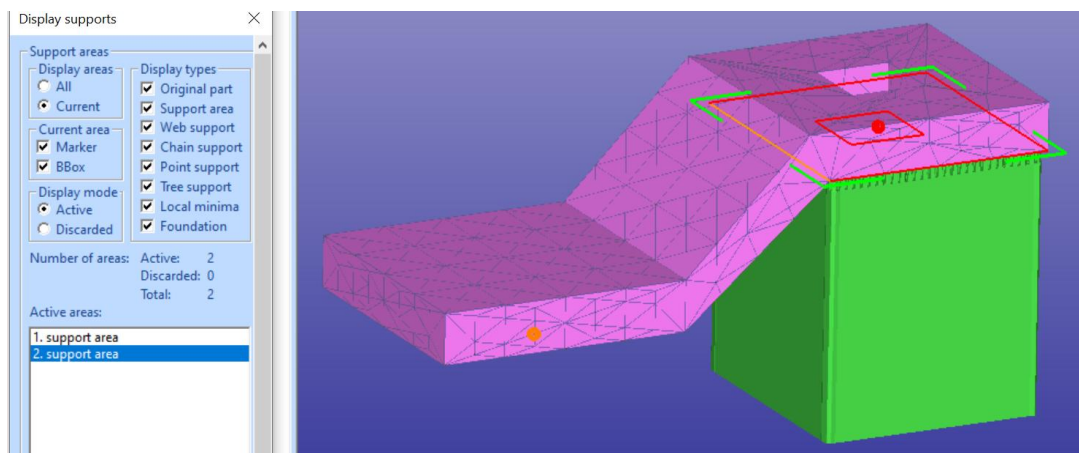

Finally, the last *Display type* selection **Local minima** shows the local minimum points with orange dot on the model. This is helpful if supports are added manually to ensure all minimum points are supported correctly:

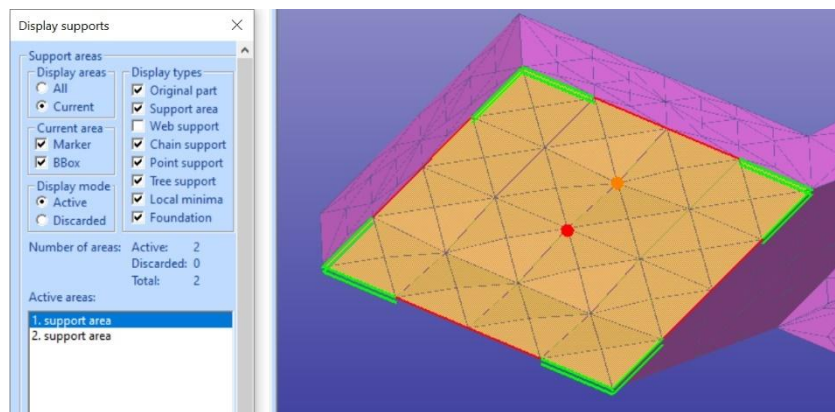

Let's now have a closer look at the supports in the second area.

- **set Off the display of the *Original part***
- **zoom into the second support area in the graphics area**

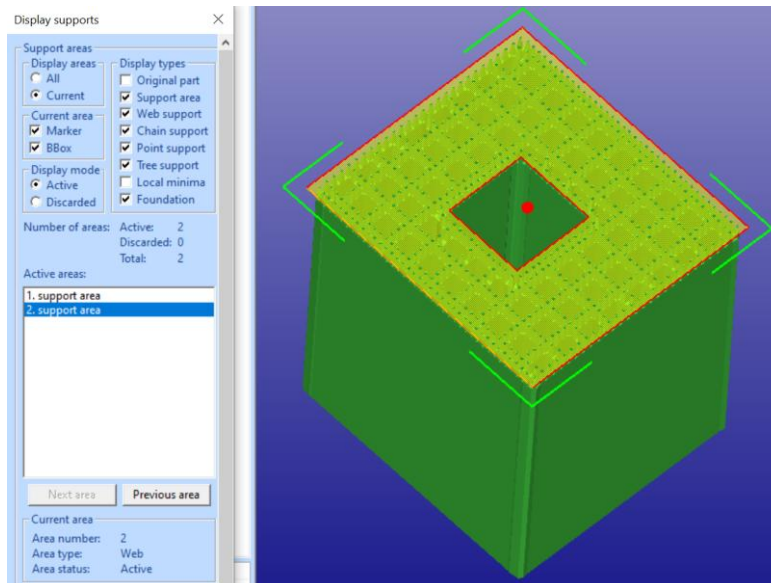

We now want to change the density of the web in the second area. To start area parameter editing we first must select the correct Create supports type in the Create supports toolbar:

- **Open the *Create supports* dropdown list and**
- **select the *Create supports for current area* selection:**

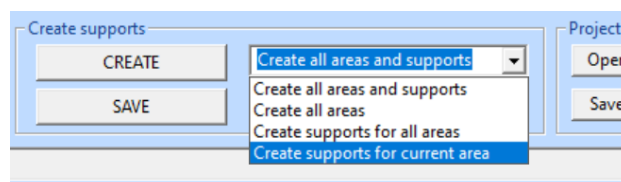

The *Edit area parameters* button now becomes active:

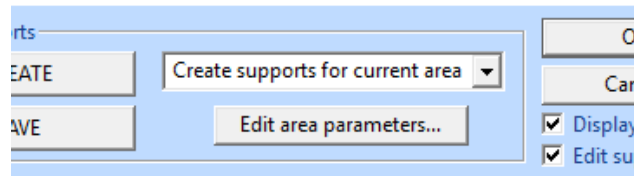

- Press the ***Edit area parameters*** button to open the Support Parameters parameter editor dialog.



The *Support parameters* dialog includes several options to edit both common parameters for all supports or to edit parameters for specific support types. This time we will just edit one parameter for Web support types.

- Press the ***Parameters...*** button in the *Web supports* group.

The *Web support parameters* dialog becomes visible.

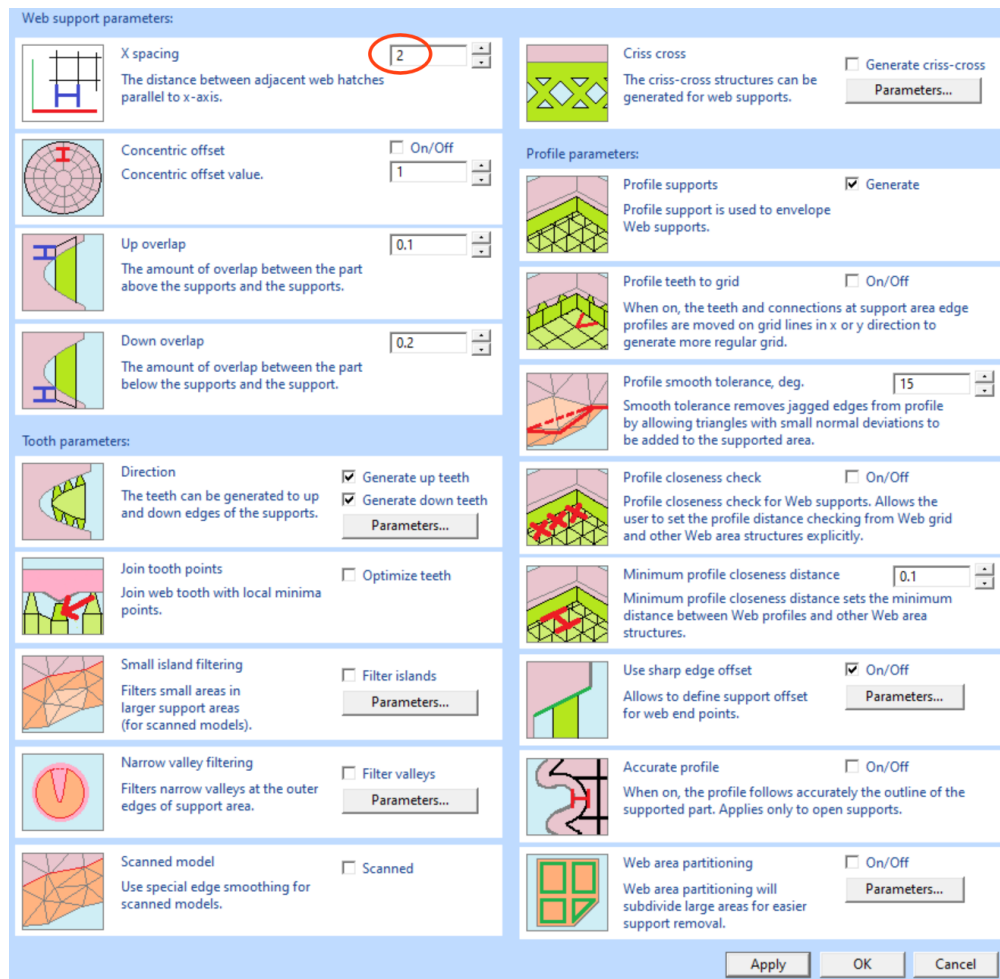

There are different options to tune the Web supports but now we just want to make the supports denser in the second area.

- **change the *X spacing*** value to **1 mm**
- **Press *Apply*** button to “*Create supports for the current area*” as set earlier in the *Create supports toolbar*.

We can immediately see that the supports for the second area change and become denser (zoomed closer to better visualize the difference):

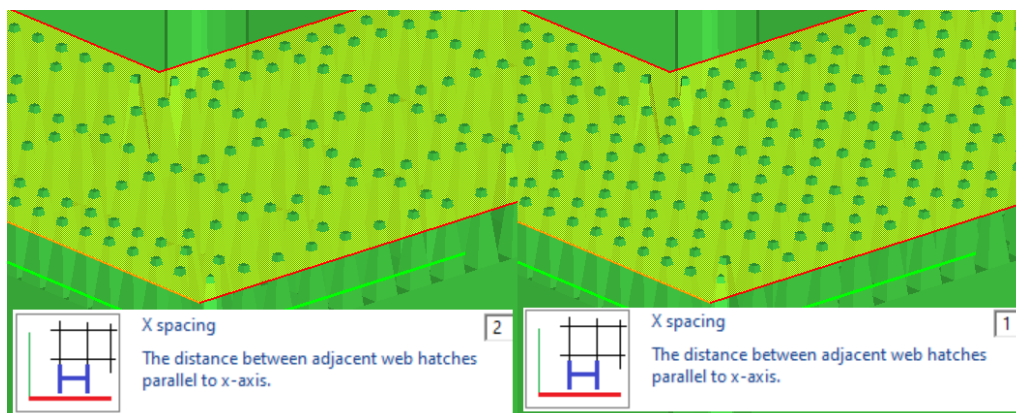

You can edit any parameter, press the **Apply** button and immediately see the change on the screen (you may need to do some panning/zooming to see the support area). This will help you to quickly find and tune the correct parameters setting for different manufacturing processes and areas in a model.

Alternatively, you can also close the dialogs one by one:

- **press OK to close** the *Web support parameters* dialog
- **press OK to close** the *Support parameters* dialog

We are back at the Create supports toolbar and can

- **press the Create button** to *Create supports for the current area* again.

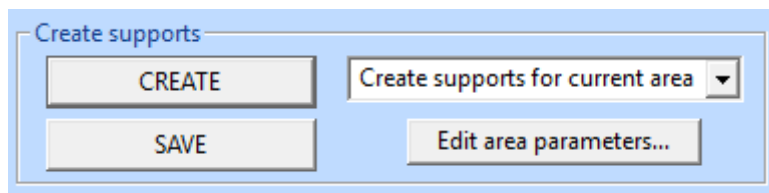

If we now

- **turn on the *Display areas type All***

we can see that the two areas now have different density for the supports.

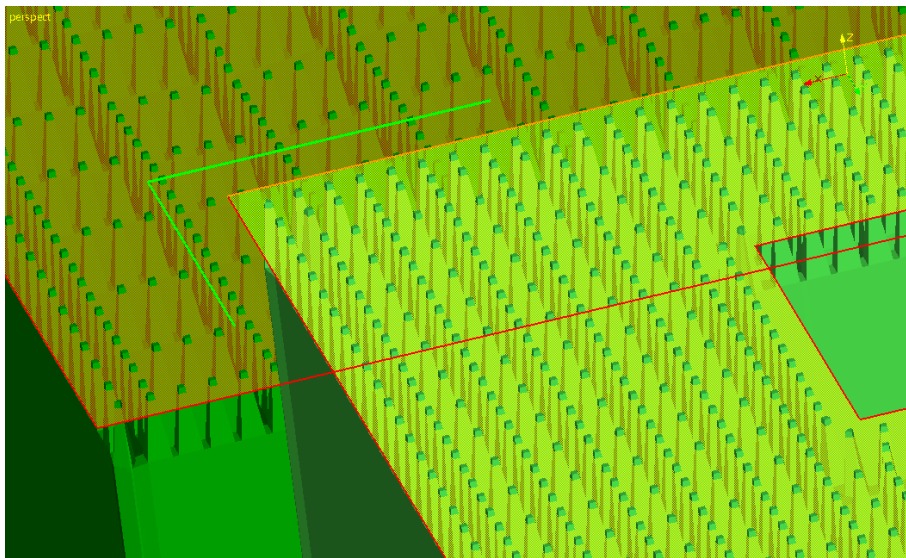

You can now

- **press OK in the *Create supports toolbar*** to save the supports in the Model Tree

You will see the two areas generated with different Web density:

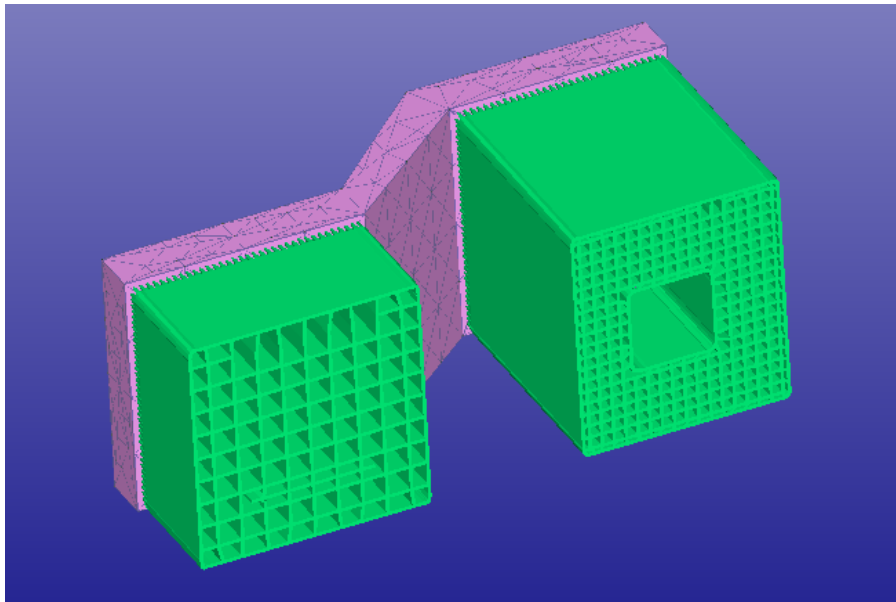

The *Apply* button in each parameter edit dialog allows you to test the changes to the parameters immediately after changing them in the parameter dialogs. This will enable quicker parameter tuning without the need to go back to *Create* button in the *Create supports toolbar*. The use of *Apply* button is explained in more detail in the *Chapter 2 – Learning the support parameters*.

Generally, you can generate supports for one or all areas at a time. Also, you can only generate areas and add the supports later, automatically or by adding them manually with support editing. The *Create support* selections have the following meanings:

Create all areas and supports

recreates everything automatically, default choice.

Create all areas recreates the areas requiring supports but leaves the actual support generation later.

Create supports for all areas

recreates the support for all areas available in the support area list

Create supports for current area

recreates the supports for the area selected in the support area list.

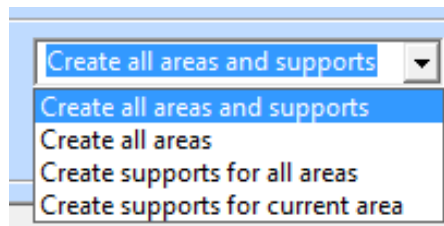

Note: If Side or Arch supports are manually created in the model (see chapter Arch and Side supports), they will disappear if *Create all areas and supports* are

3Data Expert 16.0: Tutorial 4 - Generating Supports for AM

generated. If *Create supports for all areas* is generated a warning is issued. Arch supports may be straightened but Side supports are not affected when *Create support for all areas* is performed.

Note: You can also use the *compact Support parameters* dialog when you get more familiar with the system and its parameters. With *compact Support parameter* dialog less graphics area is covered and 3D models can be more easily viewed.

Compact Support parameter dialog is used when **Use compact dial** is *On*.

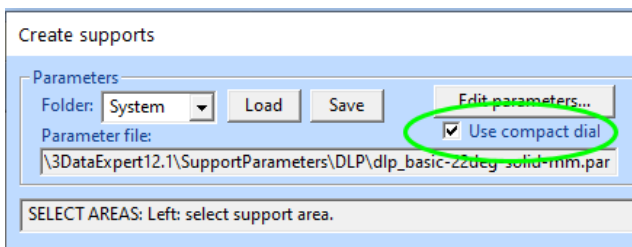

In the image right the X spacing is selected for editing. When a parameter is selected in the dialog, the lower window shows the explanation text as well as the parameter image.

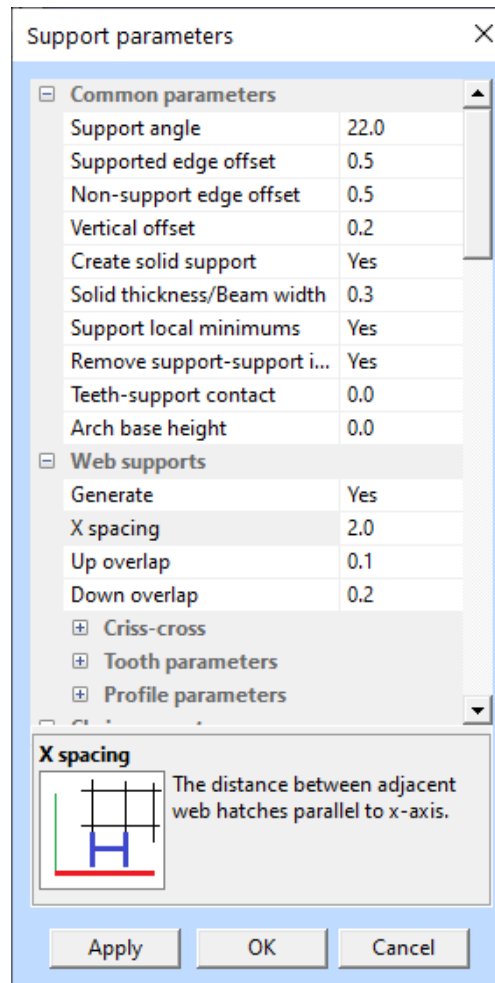

Lesson 2 – Editing support geometries manually

The Generic Support command with 3Data Expert can generate supports to most models

Adding supports manually

Sometimes it might be necessary to add supports manually. With Generic Supports command the user can add four types of supports manually: Web, Chain, Point and Tree supports.

First the area type to add is selected with the *New area* group on the *Edit supports* toolbar.

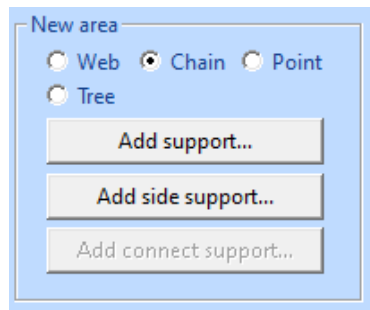

Once again,

- **open the *supp-demo1* model and**
- **press *Create* button in *Create supports* group**

All supports are now visible in the graphics area.

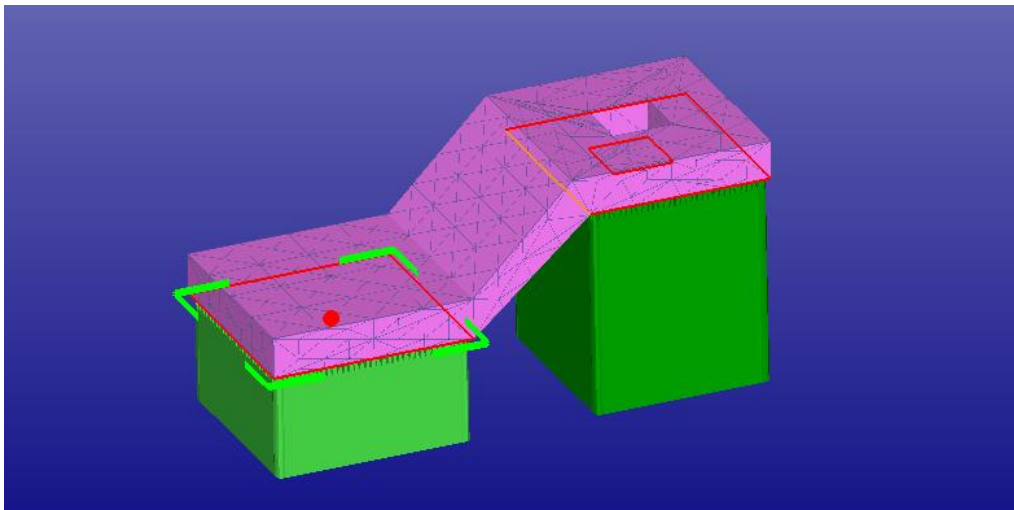

The slanted area between the two horizontal support areas does not have any support generated due to the 22-degree surface angle limit.

3Data Expert 16.0: Tutorial 4 - Generating Supports for AM

Let's now take a closer look at the non-supported area and hide the created supports. In the image below we can see the result after

- **Web support display is turned Off** (in red ellipse below)
- **the shaded+wireframe display mode is set on via the  icon in the Viewing toolbar**

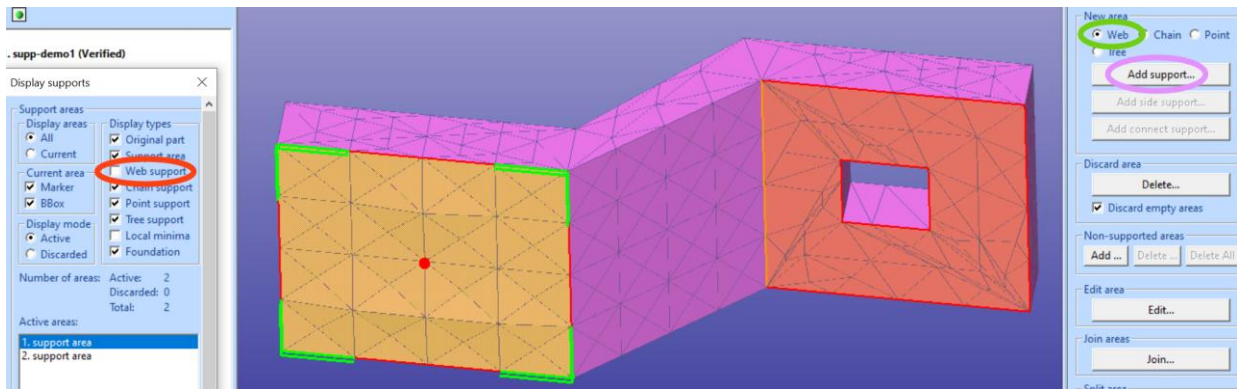

We will first generate a new Web support area. For this

- **select Web from the New area group** (in green ellipse above)
- **Press Add support button to start adding areas** (in pink ellipse above)

An area selection tool *Area operation* window becomes visible. We will use Area operations to select the triangles for new support area generation. Area operations allow you to select the area in several ways, please see the *Fix Model > Edit Triangles* command Online help for more information. This time we will use the *Surface normal* method available in the Mode selection list.

- **select the Surface normal mode** (circled in green below)

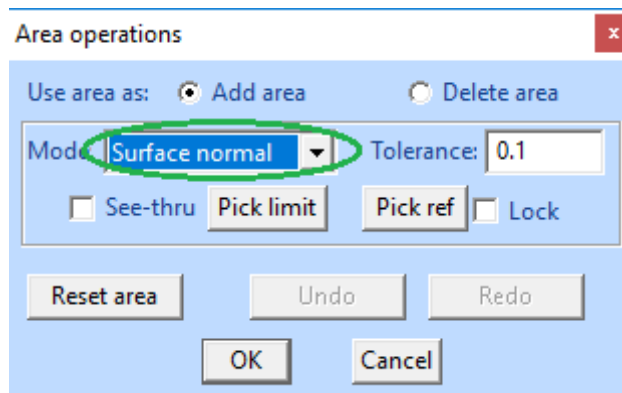

- **click on a triangle in the middle of the area with LBM (below)**

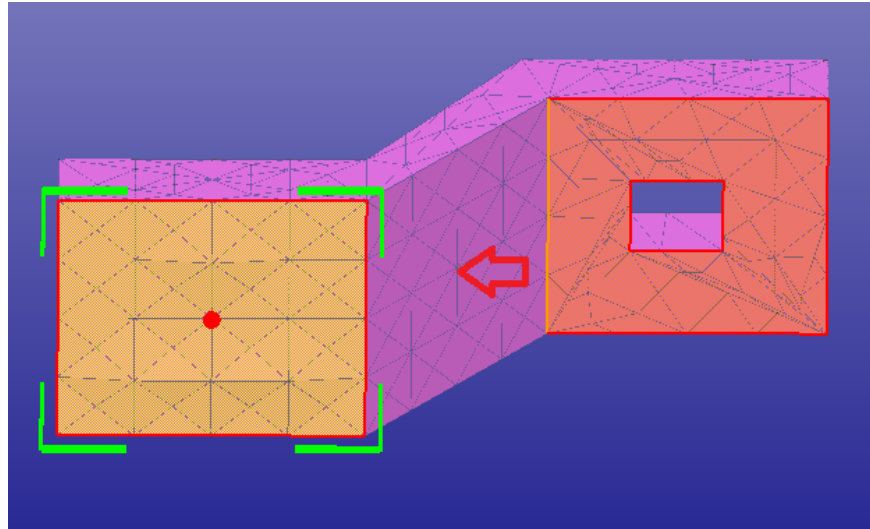

The whole slanted surface becomes greyed out and will show the triangles selected by the *Surface normal* criteria.

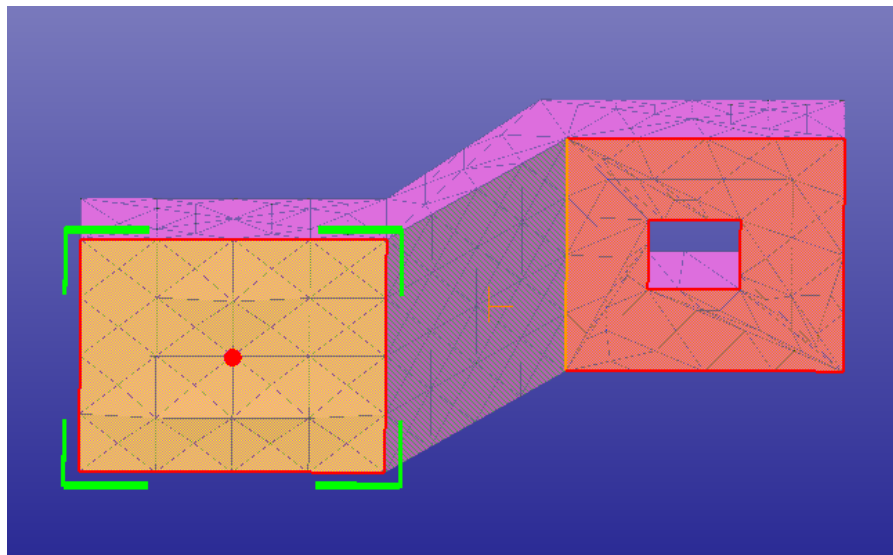

These triangles will form the new area when we press the OK button in the Area operations dialog.

- **press *OK* in the *Area operations* dialog**

A new area appears in the support area list and the triangles in the slanted area are shaded with support area color. The new area is also selected in the area list.

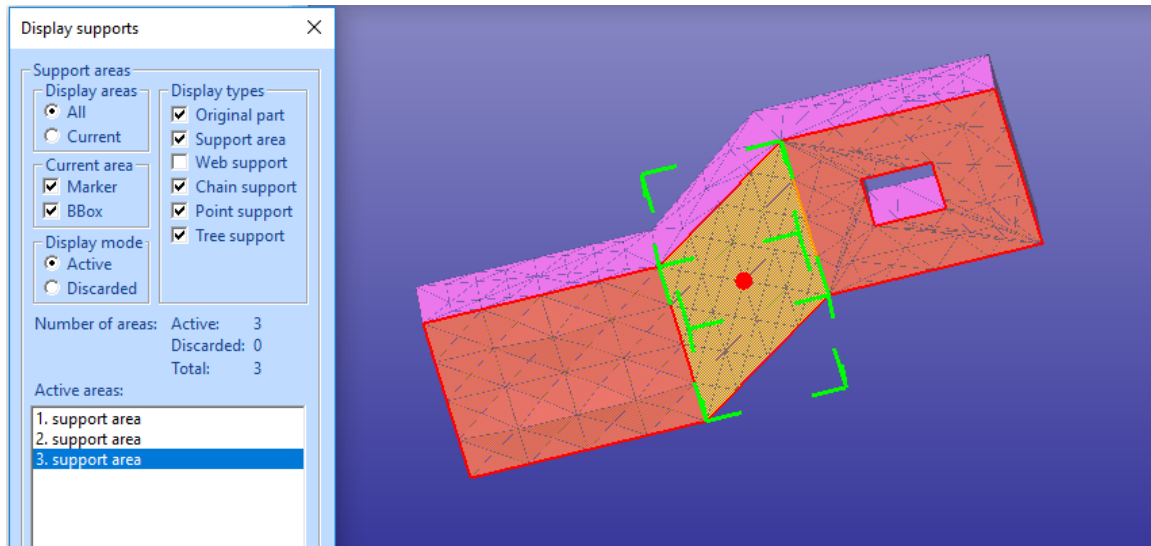

Now we are ready to generate the supports for the newly created area.

- **turn *On the Web support type*** in the *Display types* group, if *Off*
- **select *Create supports for current area*** in the *Create supports* group

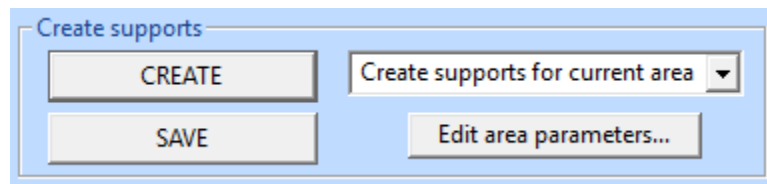

- **press *Create button*** in the same group

The supports are created for the new area using the currently available support parameters for Web area.

You will see the new support below the slanted area, as seen in the next image. (Note: you may need to increase the *Support angle* parameter to 40 deg, described later to get a full grid below the middle area)

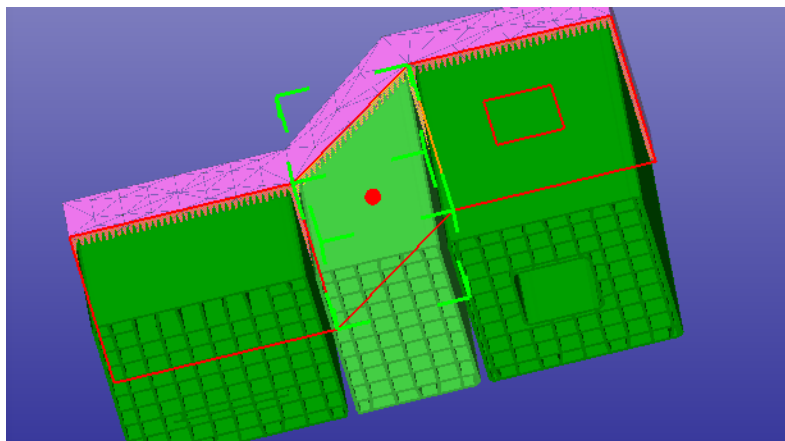

Let's now add some *Chain* supports and a *Point* support on the slanted area. You can now press *Cancel* in the Create supports toolbar to quit this exercise.

Restart again with

- **open the *supp-demo1.3de* model** (or continue with already inputted model) and
- ***Print Preparation > Supports > Generic Supports***
- **press *Create* button in *Create supports* group with *Create all areas and supports* selected**

The *support toolbars* and all supports are again visible in the graphics area.

Let's again take a closer look to the non-supported area and hide the created supports. In the image below we can see the result after

- ***Web support display is turned Off***
- ***the shaded+wireframe display mode is set on via  icon***

We will now generate new *Chain support* areas. For this

- **select *Chain* from the *New area* group**
- **Press *Add support* button to start adding areas**
- **use the *hair cross* and *LBM* on the graphics area to select two points on the surface as seen below (Alt+LMB would select a triangle corner point). If you make an error, you can undo with the ESC key.**

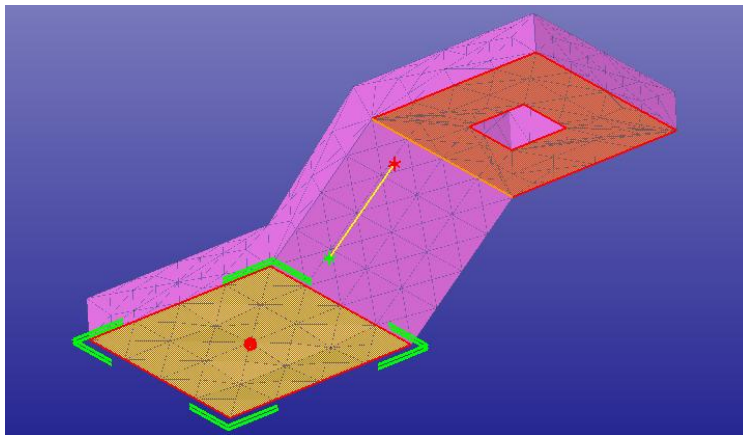

Also, the real-time Help window gives advice on what mouse button and keyboard key commands are available:

ADD AREAS: (CHAIN) : 0 point(s). Left: select chain support start point (Alt+Left: select corner), ESC: cancel add operation

- use the **RMB** button to accept the new Chain support definition
- and the Chain support is generated:

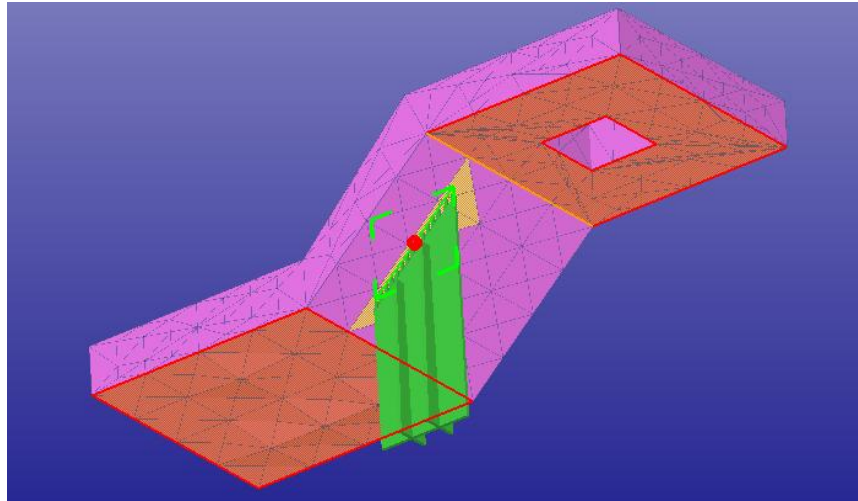

We can also add a Point support area in the slanted area.

- select **Point support type** in the **New area group**

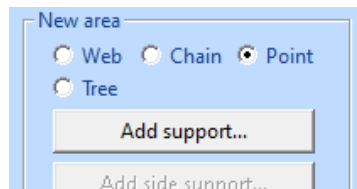

- **press Add support** to start adding **Point** supports. Select a point in the middle of the slanted area with LMB as seen below (Alt+LMB would again select a triangle corner point)

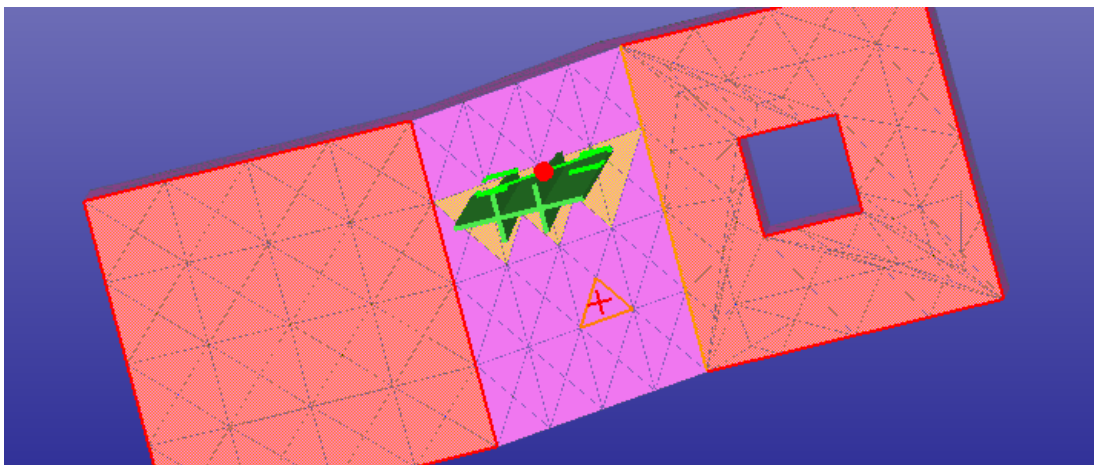

- **when ready, press RMB** to add the **Point** support area into the support area list

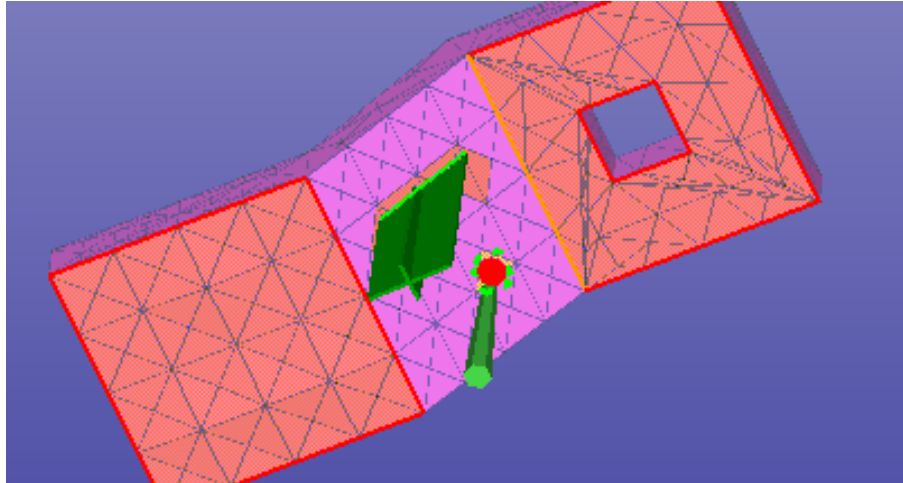

Now we have defined two new areas in the support area list, and they are automatically generated when RMB is pressed. This happens when the *Create New area automatically* setting is turned on in the *Edit > Preferences > Supports* tab:

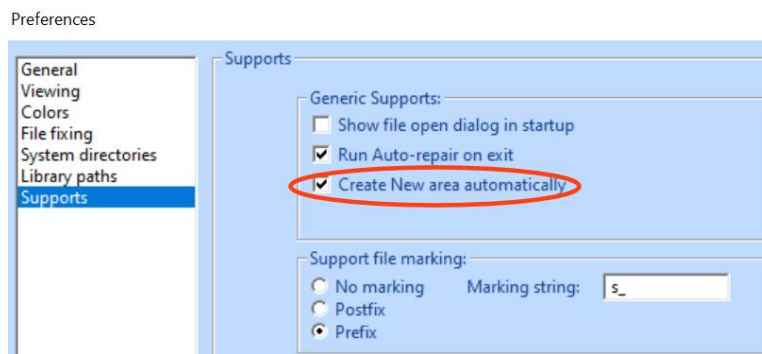

If automatic generation is not set, you need to generate the new support areas separately. For this we will select the *Create supports for all areas* in the *Create supports* group, if not already selected.

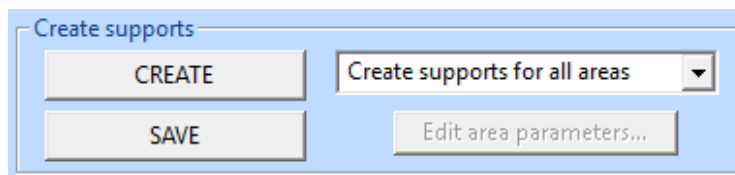

- select **Create supports for all areas** in the Create supports list
- press **Create button** and supports for new areas become visible

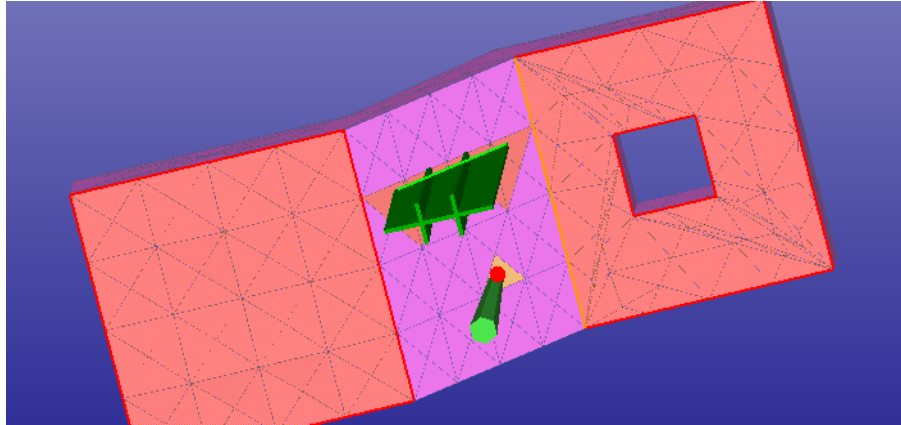

Now supports for all areas have been regenerated. Currently we can see only the new *Chain* and *Point* supports because *Web supports* have been turned *Off* in the *Display types* group.

- **set *Web supports* type back *On*** in the *Display types* group and you will see all the supports in the graphics area.

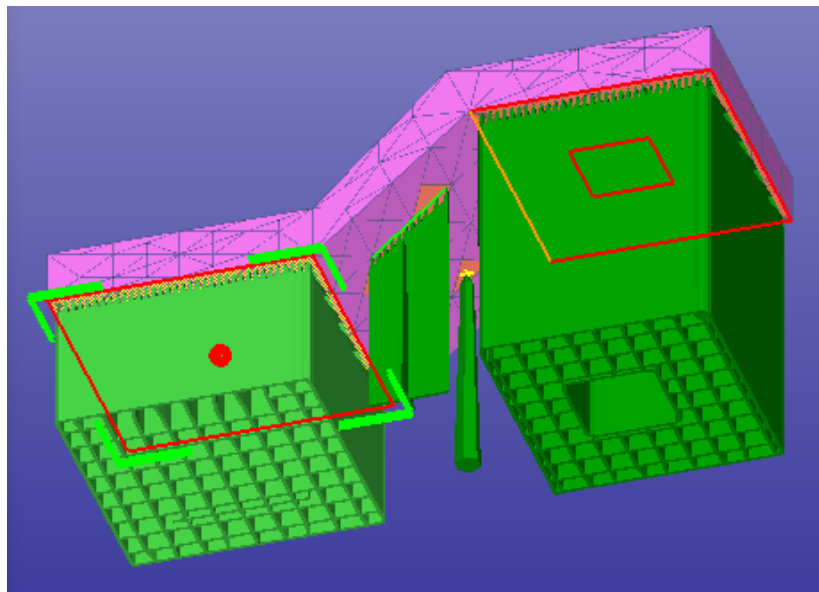

The green lines indicate the location of the Chain supports and the yellow cross shows the location of the Point support.

Deleting supports manually

There are more tools available in the support toolbars which allow you to *Delete Whole areas* and *Area details*, *Join areas* and *Split areas*.

In this exercise we will delete a whole support area as well as details inside another support area.

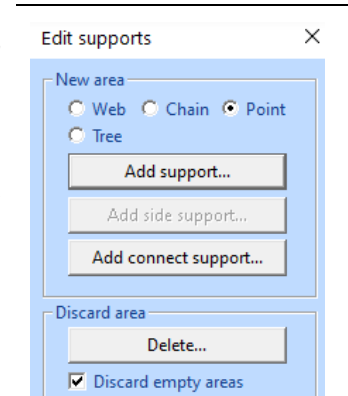

Let's now do a couple deletions from the supports generated in the previous chapter. We will first delete the recently added area, the Point area.

- **select the 4. support area in the area list** (either from the list or by clicking the area triangle on the model with LBM)
- **press *Delete* button** in the Delete area group (as in the image above). A message appears:

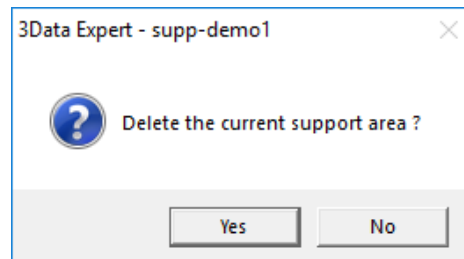

- **press *Yes*** to the *Delete the current support area* request

The Point support disappears from the support area display. However, it remains in the support area list for subsequent recovery, if necessary.

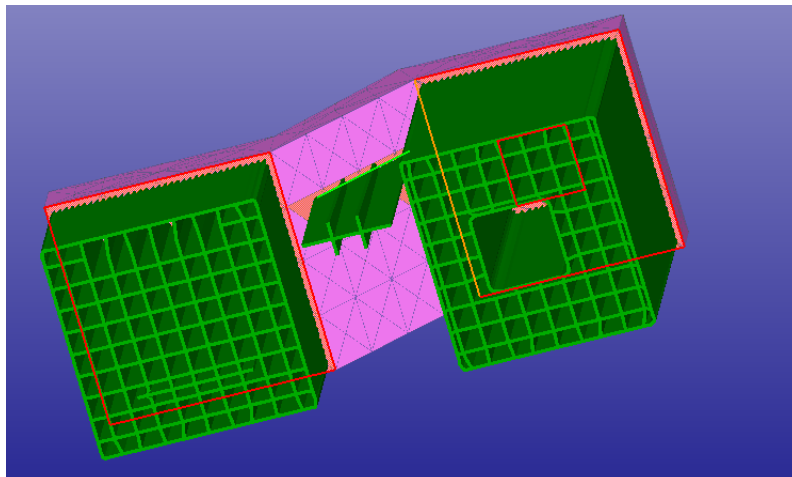

Now let's delete some details from the existing support areas.

- **First select the 1. support area** and zoom closer to it.

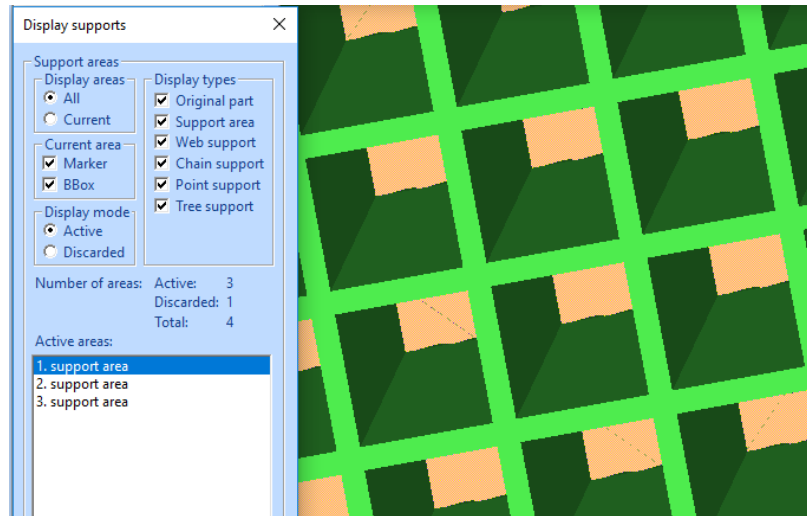

Then

- **Press *Delete details*** button in *the Modify support* group

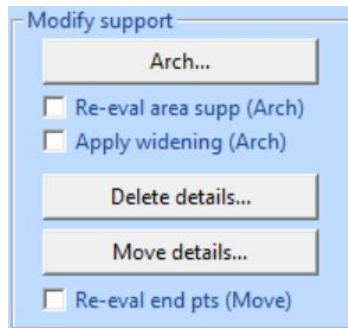

- the software goes into *support detail deletion state*. You can **select** as many web points indicated with small red cross as needed **with the LBM**. Selected points are indicated with small dots and line (1 selected in the image below). If necessary, press *ESC* to cancel a selection.

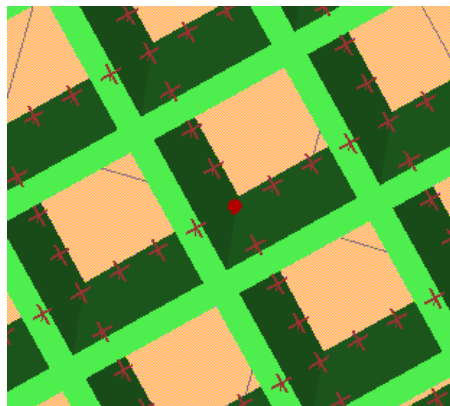

- When all necessary web points are selected, **press *RMB* to delete** the points from the support geometry.

The selected points are immediately removed from the support geometry and the system returns from detail selection state.



After the selected points are removed there is no possibility to Undo the deletions anymore. If necessary, the supports for the given area must be Created again.

Similarly, you can delete points from the newly added Chain supports:

- **select the 3. support area** from the area list (display on the Current area for clarity)
- **press the *Delete details* button**
- **select chain tooth points with *LMB*** by clicking a triangle close to an edge point

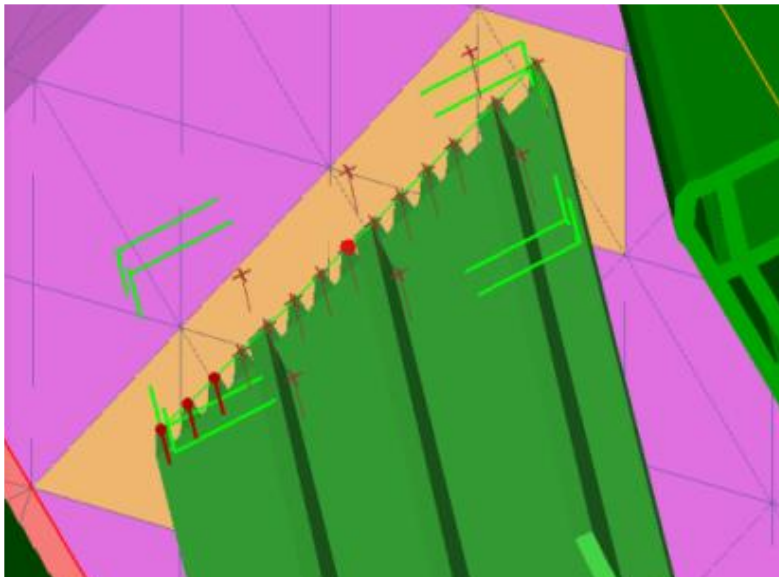

- **press *RMB* to delete** the selected points. The selected points are immediately removed from the support geometry

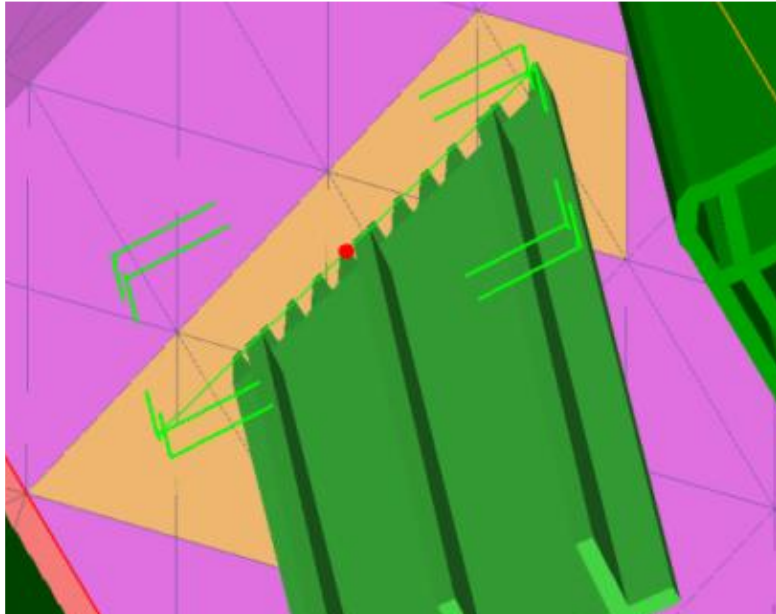

Delete area details help cleaning the support geometry in case of unnecessary points, or to prevent surface areas below the supported area to be destroyed by the supports. Of course, you must be careful not to delete too many support points to be able to correctly build the part.

Finally,

- **press *OK* in the Create supports dialog to store** the supports into the Model Tree

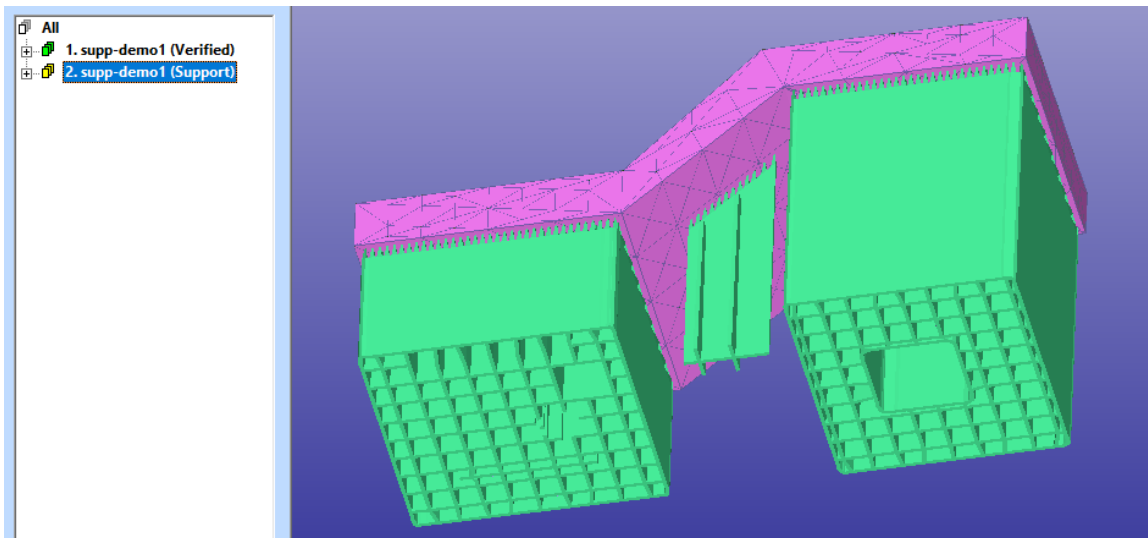

Applying Arch command to support geometry

When building complex parts with AM, the supports many times must be built starting from the actual part. Supports added to an overhang area must be built on top of an up-facing surface in the part. This will lower the surface quality on areas where the supports are built.

Generic Support *Arch* command helps to move the supports away from up-facing areas in the part. The user can graphically drag the support geometry into new location away from the part or to a less critical area of the part.

In this exercise we will use a simple part to demonstrate the use of Arch support. Start by

- **input the test model `supp_demo3.3de`**
- **start Generic Support command**
- **press Create button in the Create supports dialog**

You should see the following result on the screen:

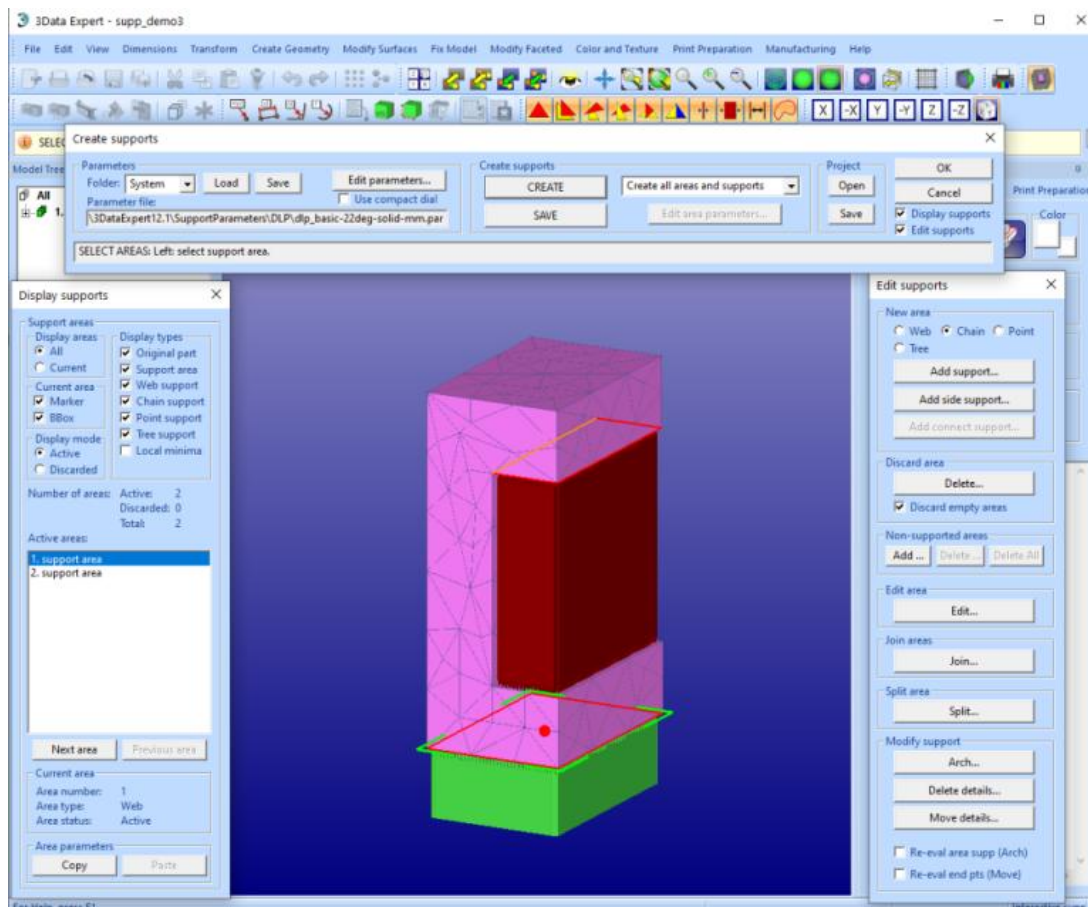

The support for the upper overhang area is hitting the part surface below. This is indicated by *red* support color.

We will now move the support away from the up-facing surface. First

- **select the 2. support area** (red)
- **press the *Arch* button** in the Edit supports dialog

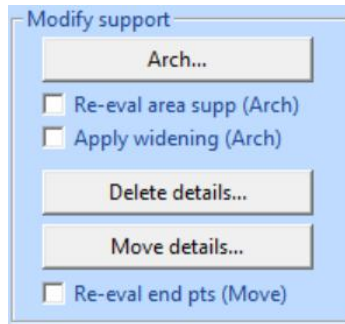

The software will display the *arch support preview*:

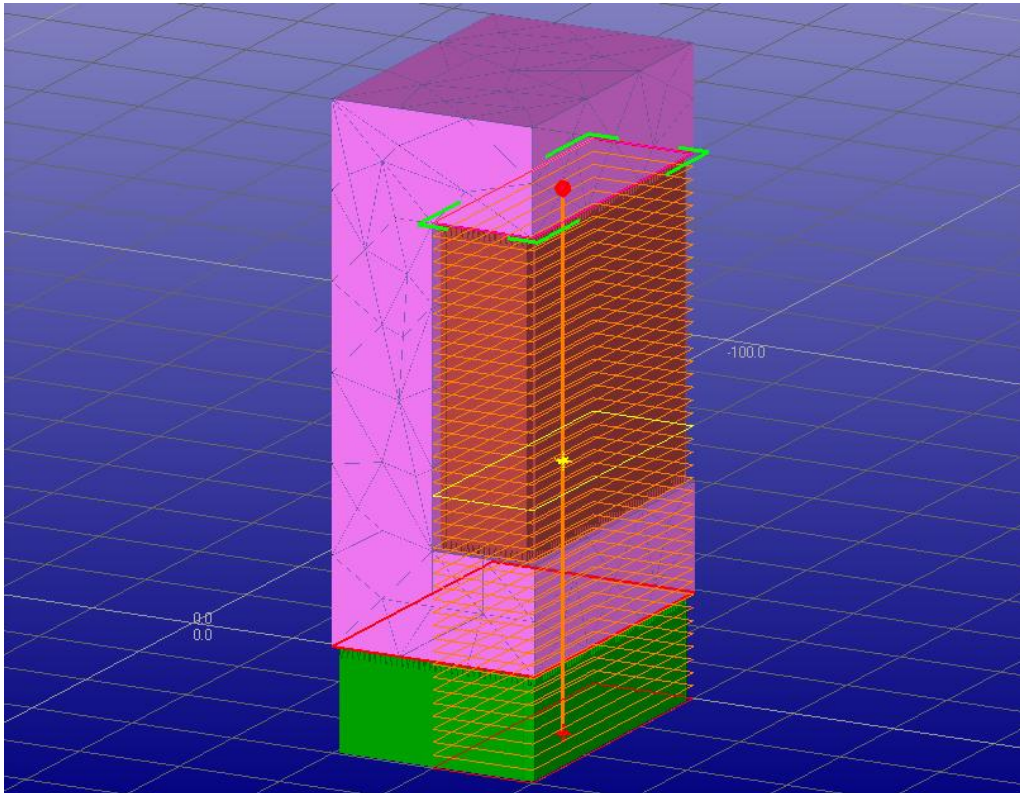

The preview shows the outline of the support geometry. The outline will help to position the Arch support correctly. The Create support dialog *Help* window will give context sensitive help on the possible operations:

BEND SUPPORT: Left: Select arch point and move, Right: End arch operation, ESC: Cancel arch operation

We will first select the arc point, i.e. the bend point of the Arch support. The point is in the middle by default, and it can be located anywhere on the vertical orange line.

- **first click on the bend position on the line with *LMB***, preferably higher than the given middle point
- **move graphically the bend point using *LMB*** until a suitable position is found. The Grid displayed in the image will help to position the support root at the XY plane.

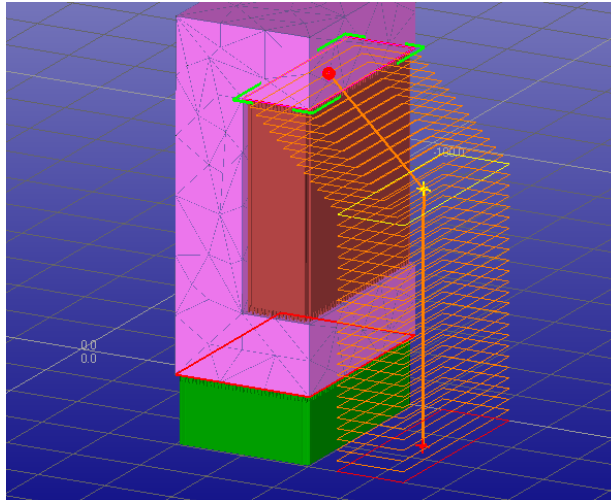

- when a suitable position is found, **press *RMB* to recreate** the support in the given location

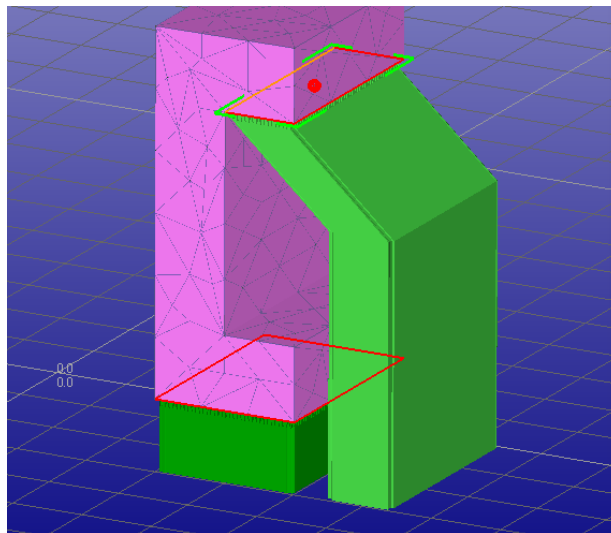

In the new location the support will not hit the actual part. The surfaces in the finished part will be smooth without support marks.

Note: Do not quit the Generic Support command with this model yet, we will continue the next exercise with the current situation.

Adding Side support

The part supported in the previous exercise is relatively high when compared to the thickness. The support of the upmost overhang area starts to support the part only in the final phases of the build. This may cause bending or other defects in the part, caused the recoating process required for layer-based manufacturing.

A *Side support* can be used to support the part from vertical or slanted walls which normally do not require supports. These supports will add robustness to the build assembly (part + supports) and/or more quickly dissipate heat from metal processes.

We will continue with the result of the previous exercise. First take a view from the other side of the part and turn on *shaded+wireframe* display:

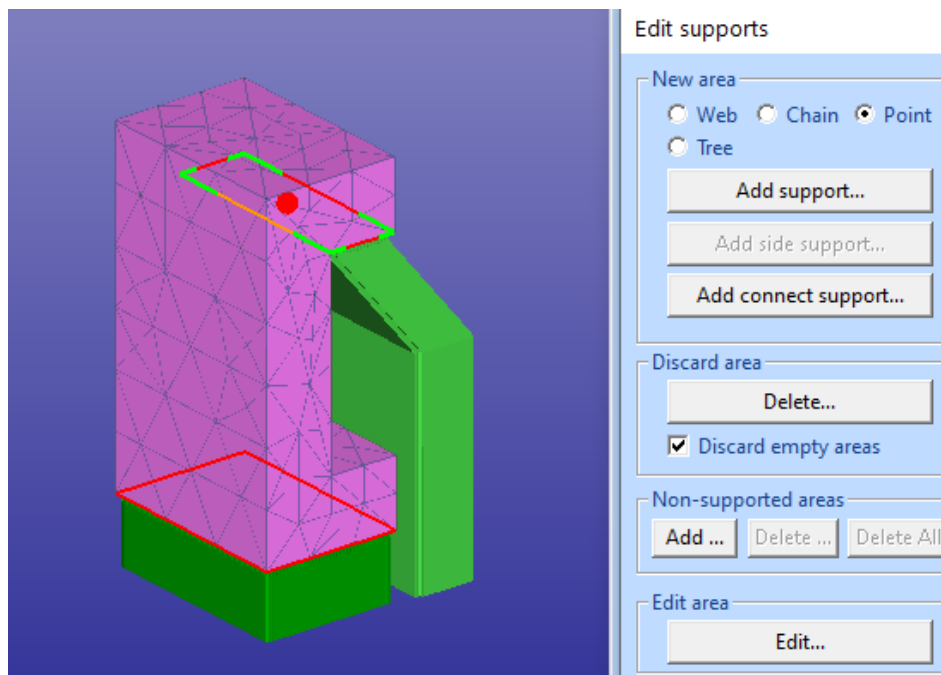

Also, you need to select the *Chain* support type in the *New area* group, as seen in the picture above.

Now we are ready to make the Side support structure using the Chain support type.

- **press the *Add side support*** button
- **draw the Chain support polyline from the part surface** as seen in the image below. Click on the consecutive triangle edges with *LMB*. Press *ESC* to undo in case of errors.

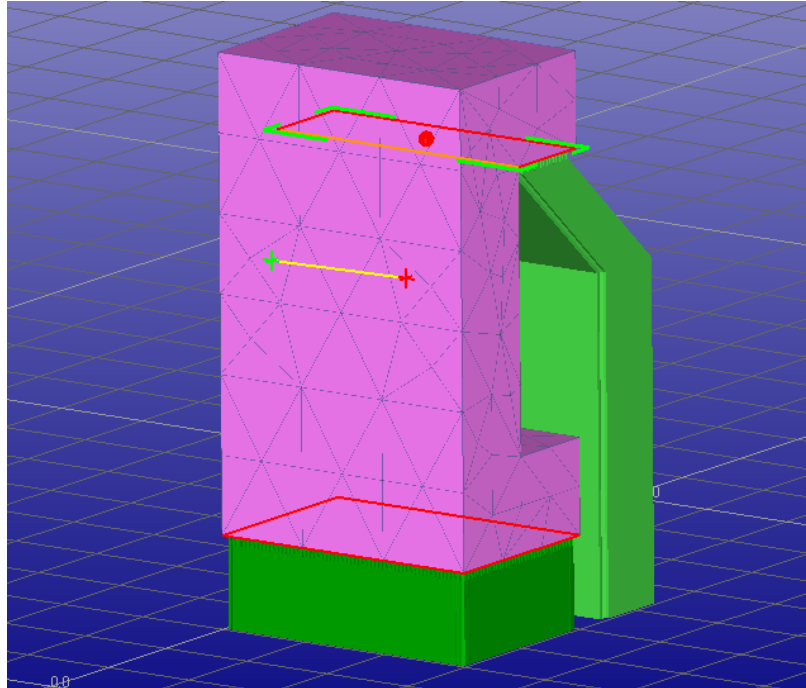

- when the polyhedron is correct, **press RMB to accept the polyhedron**. The side support polyhedron and triangles are displayed on the part

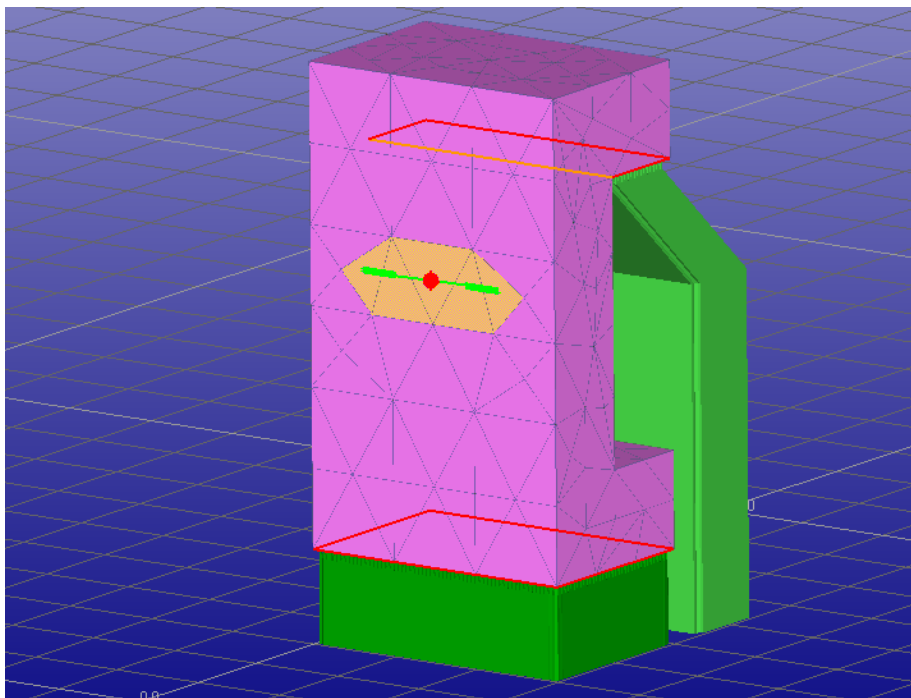

- **press Z projection button** () to take a view from up
- **show the Side support root point with the LMB** on the XY plane. The *side support preview* is displayed on the graphics area

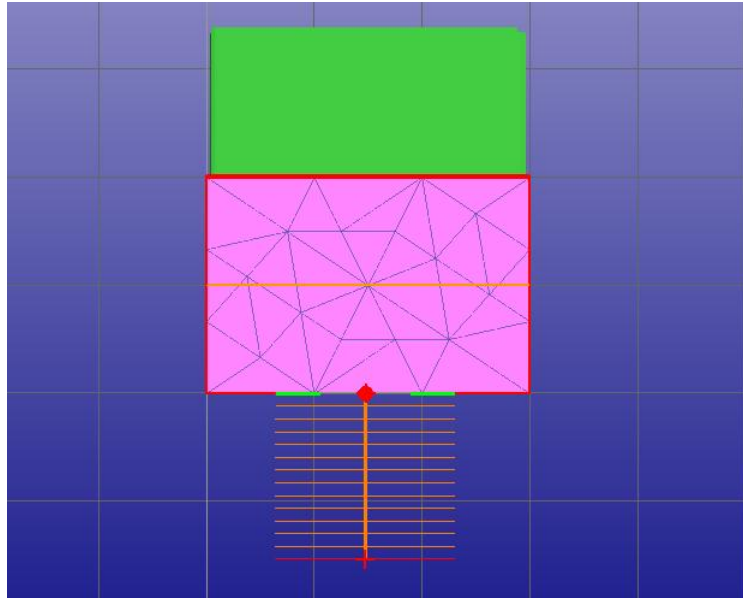

- **press RMB to accept the bottom point** (or *ESC* to undo and reset)
- **press X projection button** () to take a view from front

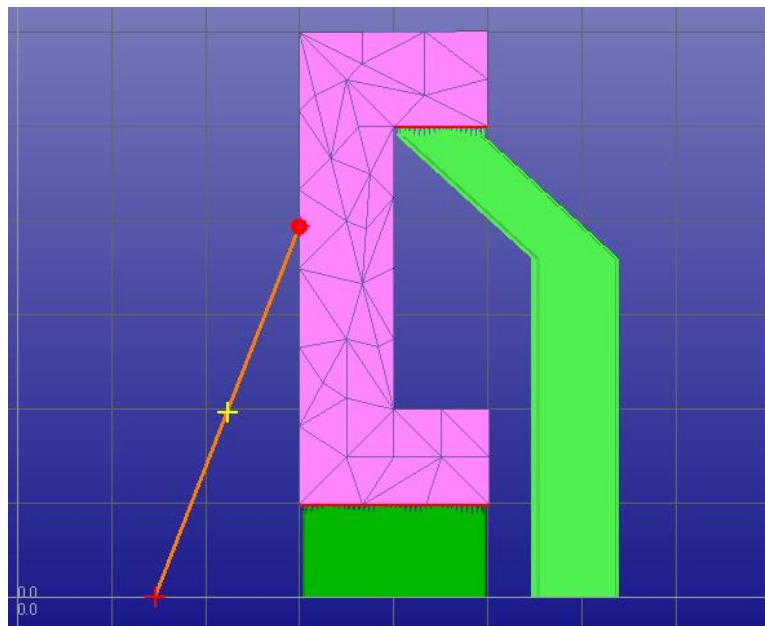

- **press with *LMB* on the orange preview middle line** to indicate the bend point for Side support
- **and move to correct location with *LMB+dragging***

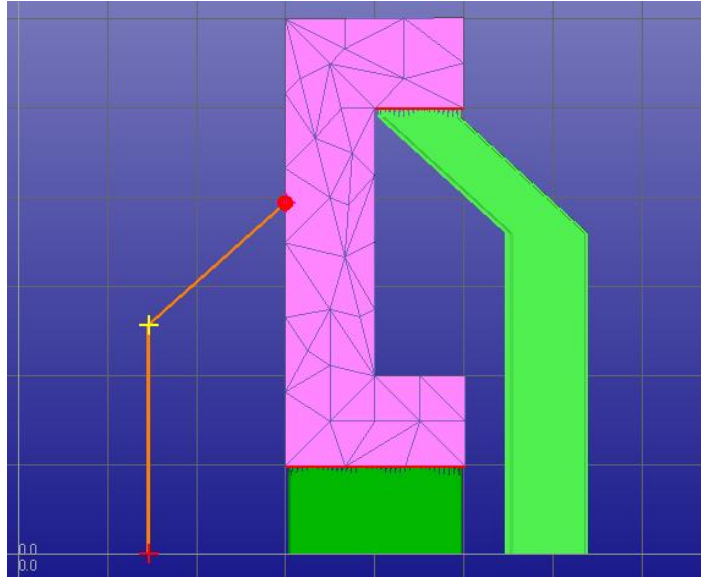

- press **RMB** when ready to generate the Side support

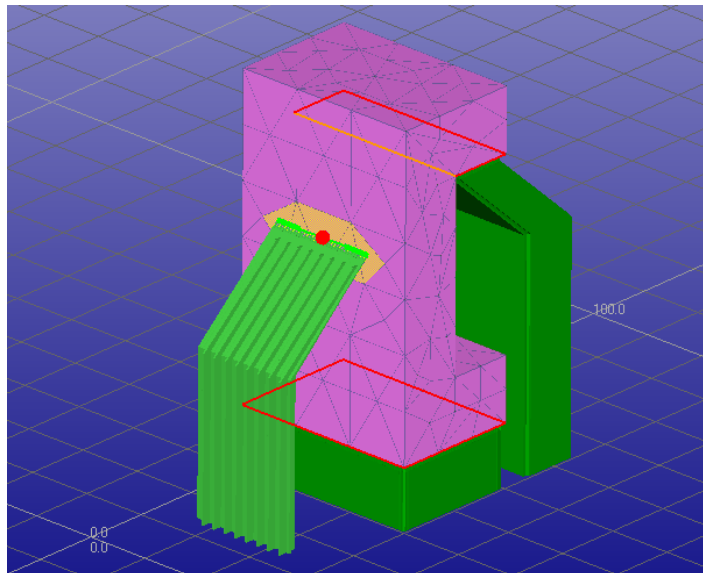

The added Side support geometry will increase the robustness of the build significantly.

During the Side support drawing we were using Z and X projections. The drawing and dragging can also be done in 3D view but many times it is more accurate to take projection views for support drawing operations.

You can now

- **save the supports into Model Tree by pressing OK** in the Create supports dialog

Note: When the supports are stored into the Model Tree they are checked for errors when solid supports are used. This may take some time due to the Arch supports which cause more triangle-triangle intersection checks than normal supports.

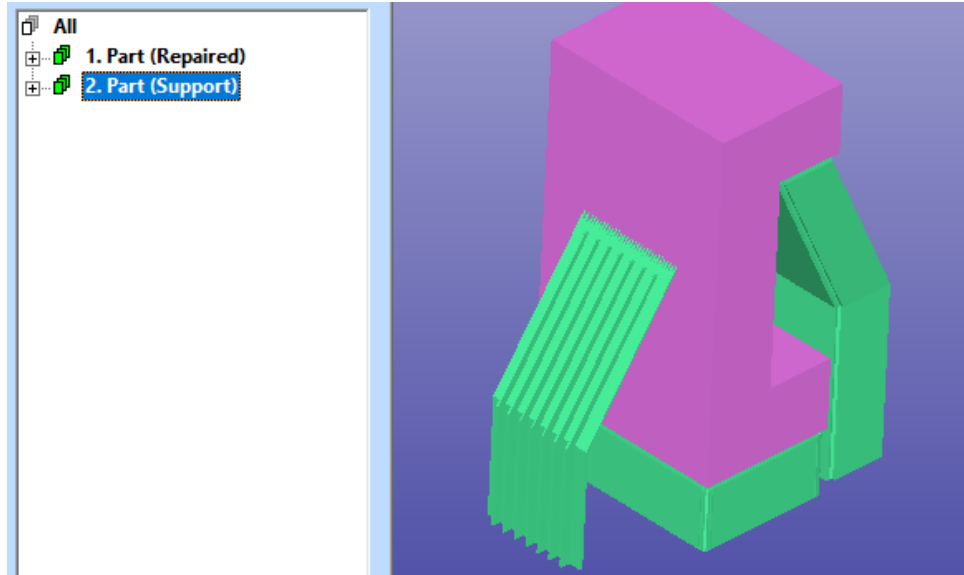

In the above example, the Side supports were based on Chain support type. Chain supports are normally created to down-facing sharp areas and lay relatively horizontal. Thus, it is a good practice to draw the Side support when using Chain type horizontally, otherwise the supports may have some artifacts in the result (not a proper solid).

Adding Tree support

Let's now have a look at the last support type, *Tree supports*. Tree supports are created by drawing a tree like net with tree root and branches.

The tree support is generated in phases: First we will select the top of the tree on the part surface. Then the tree root is shown on the XY plane. After that we can add branches, move points and tune the tree thickness in different levels.

The Tree parameters are set through Tree supports parameter dialog accessible via Support parameters dialog:

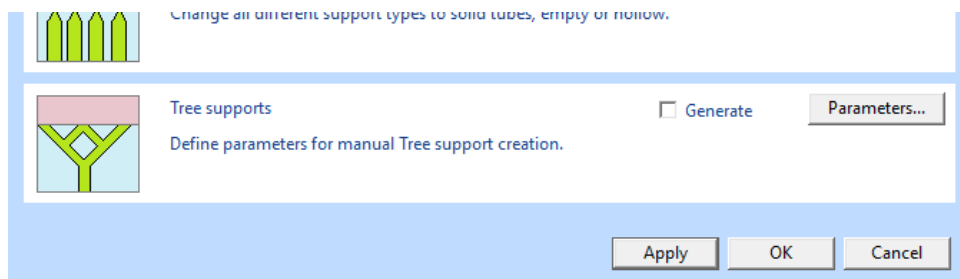

As an example we will use a simple ring-like geometry. The supports for this model could also be done using the Arch support, as seen in the image below but this is left as an exercise to the reader.

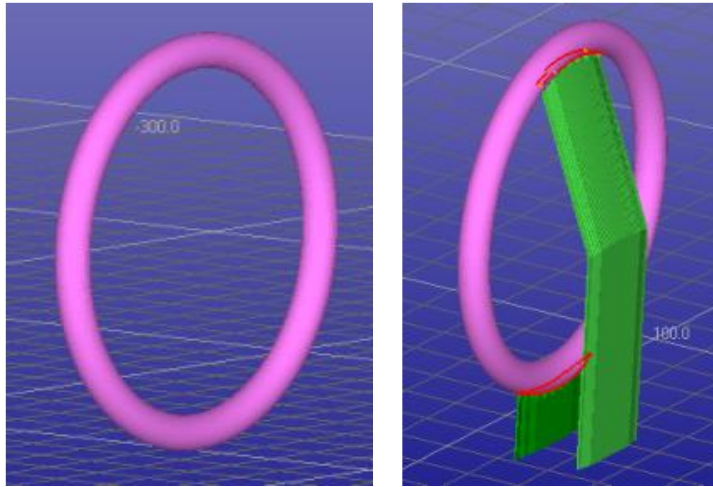

We start the Tree support generation by inputting the ring model.

- **input the test model `supp_demo4.3de`**
- **start **Generic Support** command**
- **press **Create supports to generate automatic supports****

This time we will delete the *2. support area* from the part and generate a less invasive Tree support instead. The *2. support area* hits the surface below and we want to avoid that. Also, a Tree support will potentially use less material. Sometimes it can be sufficient to use an Arch support to bend the support away from the surface below.

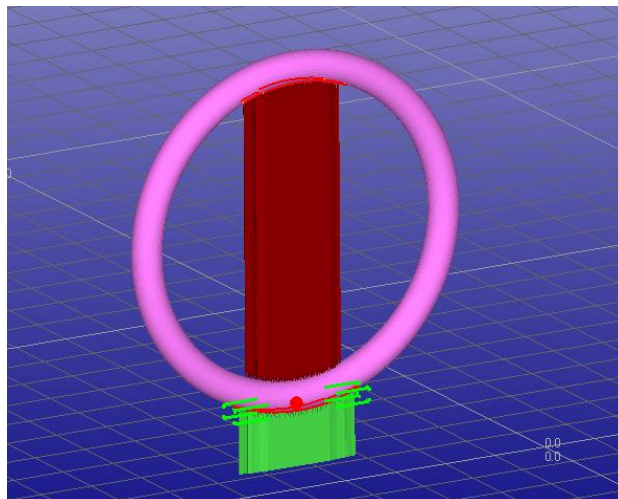

- **select *2. support area* and delete it using *Delete whole area* command in Edit supports dialog**

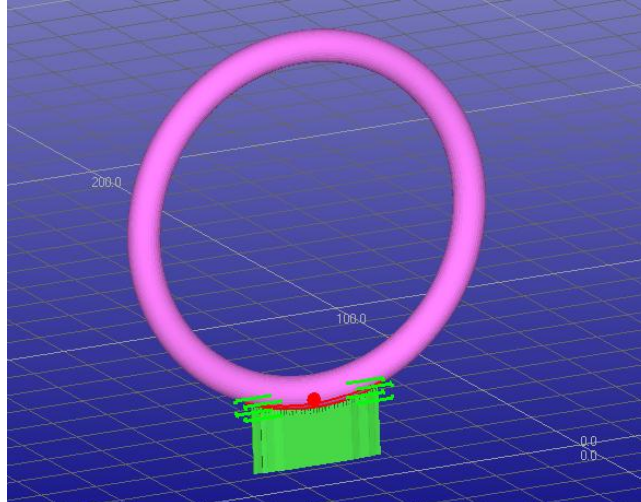

- select **Tree** type in **New area** group

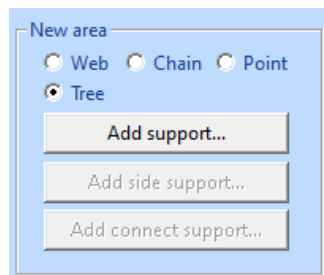

- and **press Add support** button and **Create tree supports** dialog appears:

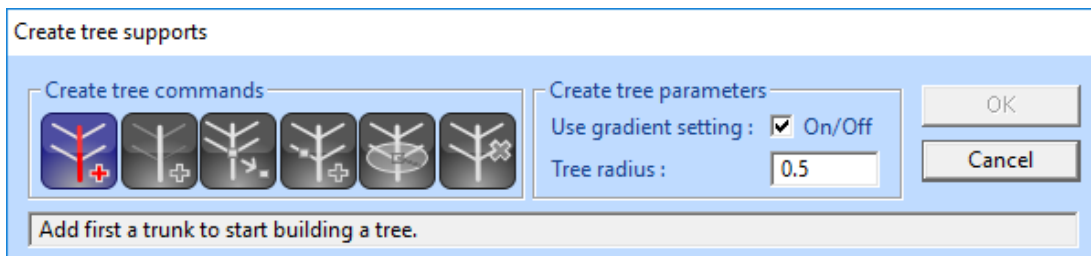

This dialog has all necessary commands to draw a Tree support. Also, the help text window gives context sensitive help to take through the tree generation easily.

It is a good idea to first take a "slanted" view to the model. This will help to position the tree tip to the correct position.

- **rotate the view** so that it is visible from the bottom (almost, see below)
- **press Add trunk icon** to define the tree trunk



- **show the location of the tree tip on the model with LMB** (red cross in the image below)

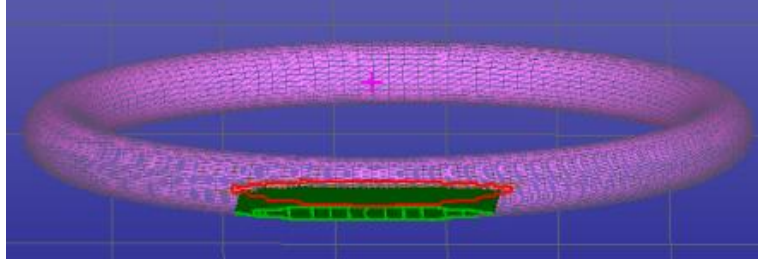

- take a view from the Y axis direction with **Y**
- show the location of the trunk root with **LMB**, preferably below the XY plane, as seen in the picture below

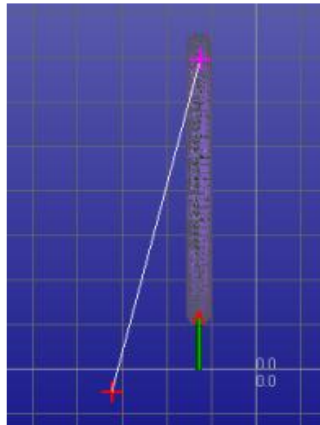

- press **RMB** to accept the root location (or ESC to reposition)

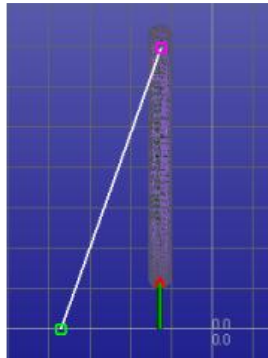

Now all tools in the Create tree supports toolbar become active and we can start adding branches to the tree.

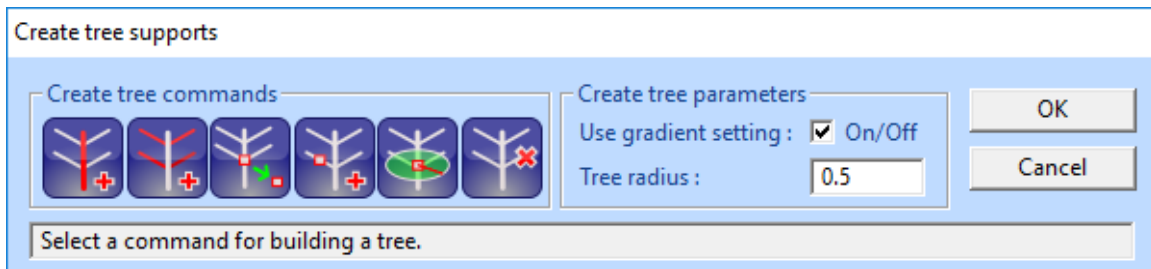

We will generate two new branches to the tree. Once again, we take a view almost from the bottom to be able to position the trunk tips correctly.

- first press **Add branches** icon 
- then click on the model surface with **LMB** (red cross in the image below)
- then click on the tree trunk with **LMB** to add the branch point (blue point in the image below)

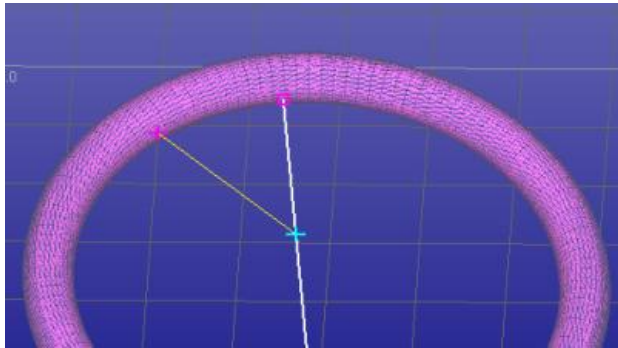

Now we have added one branch on the tree. The second branch is added similarly, first click on the model surface then on the same location on the tree as the previous branch point on the trunk. You should have something similar to the image below. You can always *Undo* by pressing *ESC*.

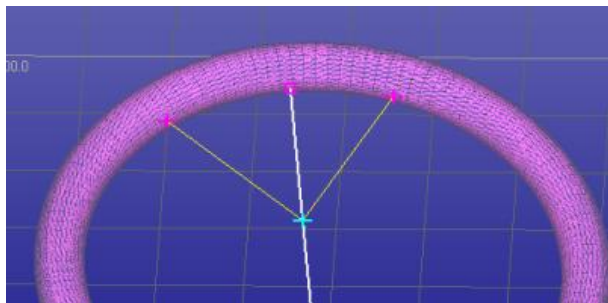

- when all branches are added press **RMB** to accept the new branches

You should have a tree similar to the image below. Now you can either move the points with the



icon or you can add wanted thickness to selected nodes in the tree with the



icon.

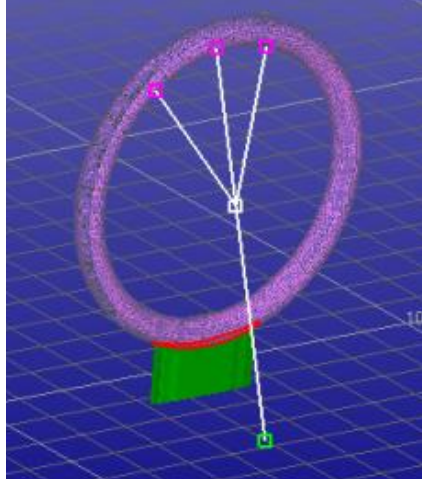

The Tree thickness in the loaded parameter set is very small, 0.5 mm. We want to adjust the tree thickness in different nodes for more robust build.

First set the Tree radius to 4 mm

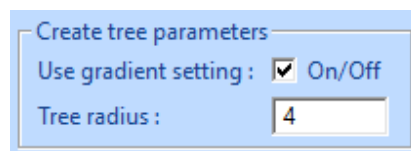

Then



- **press icon**  **to change the tree radius at a point**
- **and select the tree root node.** The new radius for the tree root will be displayed on the tree preview

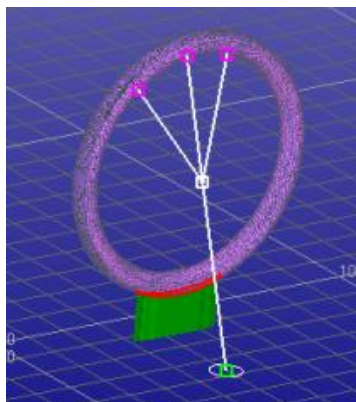

- **change the Tree radius to 2.0 mm**
- **and click the middle branch with *LMB*.** The middle branch will have a new diameter 2.0 mm

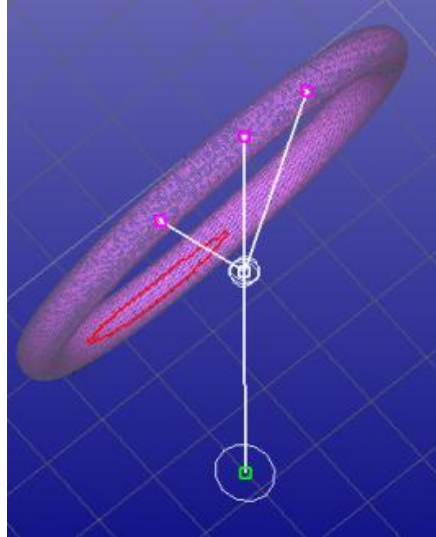

The new radius values will be used for the tree generation instead of the original 0.5 mm value set in the Tree support parameter dialog.

- **press *RMB* to quit changing tree radius**
- **press *OK* in the *Create tree supports* dialog (or *RMB*) to store the new tree in the support area list and to generate the supports geometry**

And the Tree support is ready.

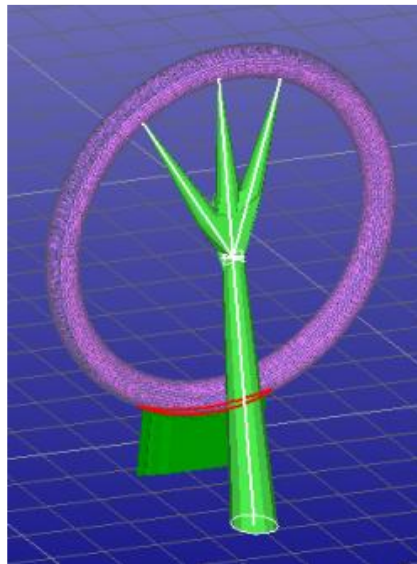

- **press *OK* to store the supports in the Model Tree**

The ring and the supports are now ready to be manufactured with suitable AM system.

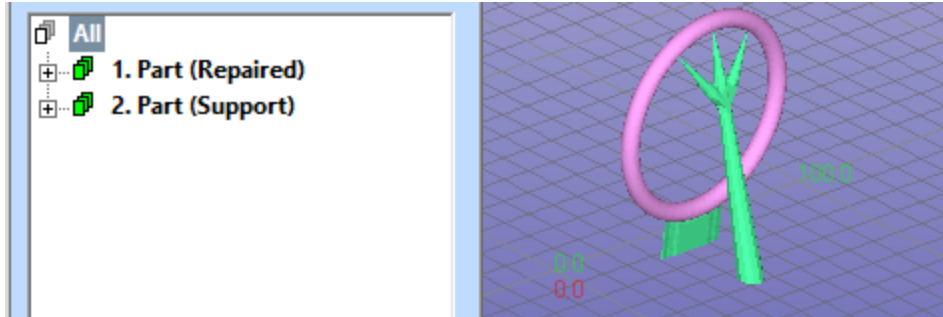

The above examples were all done using solid support structures. This mostly for a better viewing experience: zero-volume open support plates do not perform visually well. These examples can be done using the corresponding “open” parameter files available in the installation package.

Lesson 3 - Learning Support Parameters

The Generic Support command with 3Data Expert can automatically generate supports to most models. For the automatic process to succeed with different processes, like metal or DLP, a suitable set of parameters needs to be given to the program. The software installation comes with several Print Configuration parameter files tuned towards different processes. Anyhow, the user must check that the given parameters and generated support geometries are suitable for the receiving AM system.

Opening and saving support parameter files

The support parameters are part of a Print Configuration which contains the parameters required to prepare the model for a specific AM system. When you start 3Data Expert, the Print Configuration set defined as your default is loaded. The Print tab shows you the most common parameters and contains the button  to open the configuration editor (if you cannot see the Print tab, type Shift-F8):

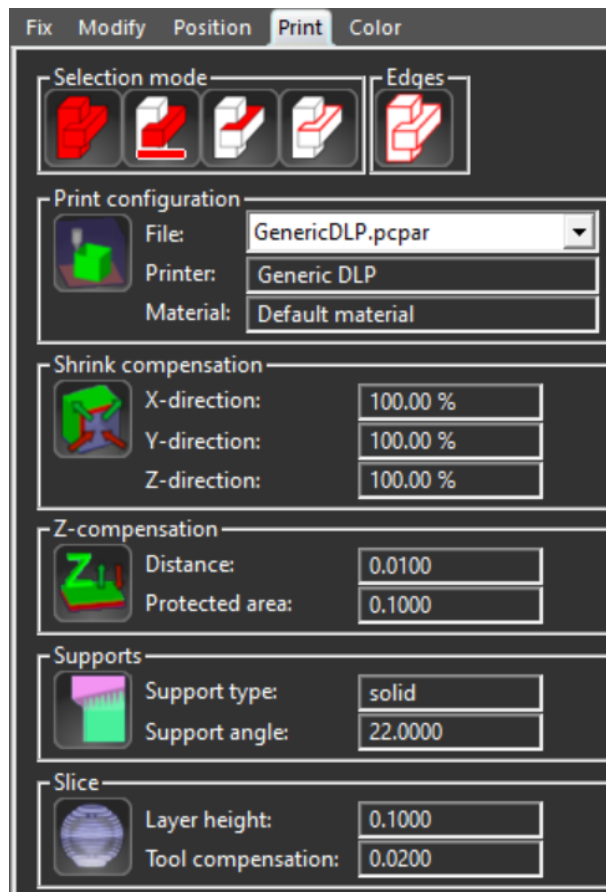

- Click  to open the Print configuration editor:

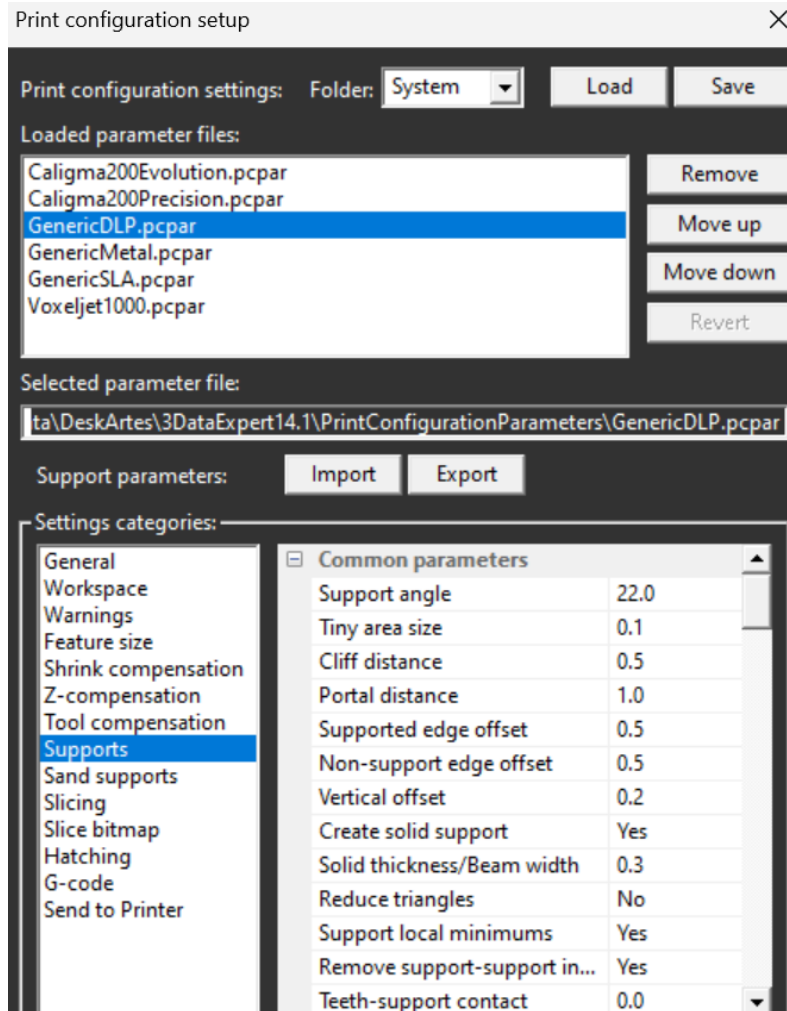

Because we are now interested in support parameters, we will not go into details of this dialog here. It suffices to point out that with the *Load* and *Save* buttons you can manage your own copies or backups of the Print configuration settings. Also, even if support parameters are built inside the Print configuration, it is possible to separately *Export* support parameters of the current Print configuration, as well as *Import* a previously (or elsewhere) saved support parameter set. This functionality allows you to test the parameters without losing original settings.

- **Close the Print configuration setup window** with the **Cancel** button

Now let's start with the same example as before. Once again,

- **open the *supp-demo1* model**
- *Print Preparation* > *Move to Platform* > ***Move Positive* with 10, 10, 10**
- **Start the *Generic Support* command**

The first *Parameters group* in the Create supports toolbar includes file *Load* and *Save* options. These buttons do the same as the similar buttons in the Print configuration setup window: they allow you to switch between Print configuration sets and make backup copies of your current parameters.

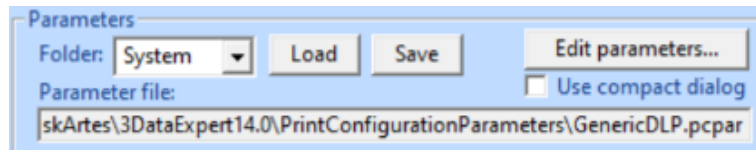

The predefined parameter files which come with the installation are installed in the System folder. These files cannot be overwritten without administrator rights.

Editing Common support parameters

The support parameter editing is done via a set of parameter dialogs. There are currently 6 different dialogs for different support types. The first, *Common parameters*, affect all support types. Three support specific parameter dialogs, *Web*, *Chain* and *Point support parameters*, affect the different support types respectively. If set, the *Tube supports* and *Tube support parameters*, allows to convert all above support types to tubes. The Tubes supports are useful for medical applications, like titanium teeth implants. Tree support parameters currently define the parameters for manual Tree support addition (later an automatic conversion of all supports to Tree is implemented).

All support parameter dialogs include both image and textual explanation on each parameter. This makes it very easy to understand and modify the parameters for an optimal support result. In the sequel we will mostly rely on the parameter explanations given in the dialogs and concentrate to describe the effect of each parameter change.

The effect of a parameter change is best observed by pressing the *Apply* button on the bottom of each parameter dialog. Pressing the *Apply* button all parameter changes are updated immediately to the support preview in the graphics area. You can use different viewing commands (pan, zoom, rotate) when the parameter windows are open to take a better view to the part and supports.

With low-resolution screens it might be better to press OK on each parameter window and execute the *Create* command when the graphics window is fully visible. Some of the parameter dialogs are quite large and may hide the part and supports. Alternatively, you can use the *compact dialog* mode.

Continuing with the *supp-demo1* model in the Generic Supports state,

- **press *Create* button in *Create supports* window**
- **set *Create supports* setting to *Create all areas and supports*, if not already set**
- **press *Edit Parameters* button in the *Create supports* toolbar**
- **press *Common parameters* in the *Support parameters* dialog**
- **zoom in/pan** to have unobstructed view to the part and supports, as seen in the image below

3Data Expert 16.0: Tutorial 4 - Generating Supports for AM

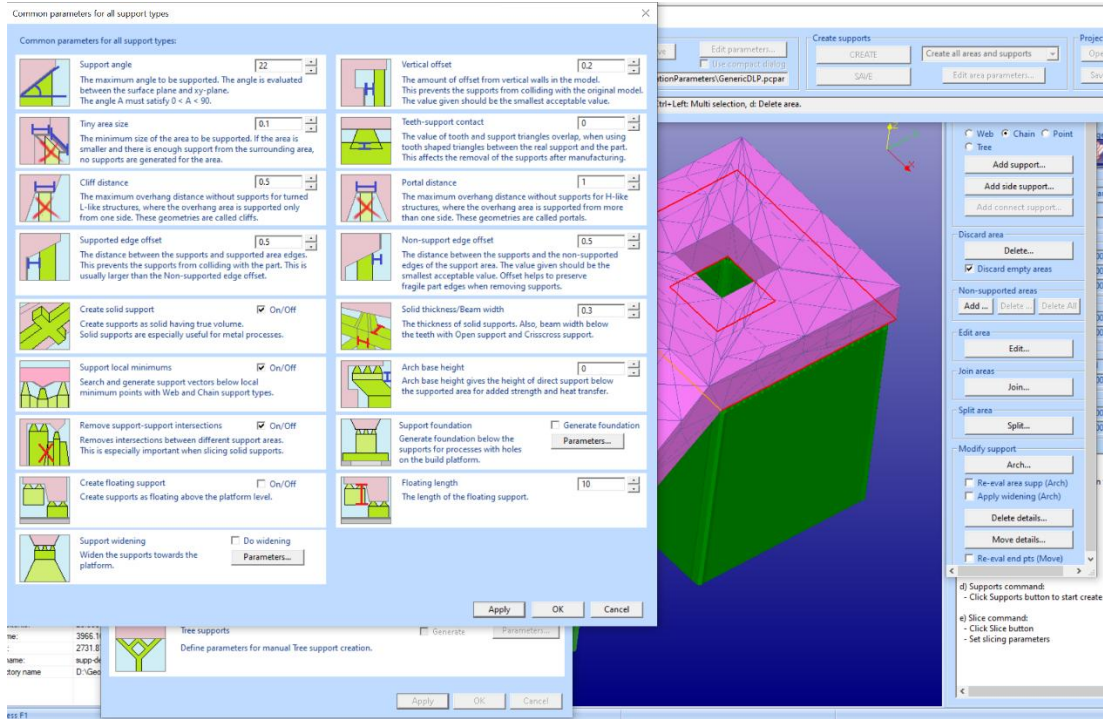

Your screen should now look more or less as seen above, the model and supports on the right-hand side of the screen and support parameter dialogs on the left-hand side of the screen.

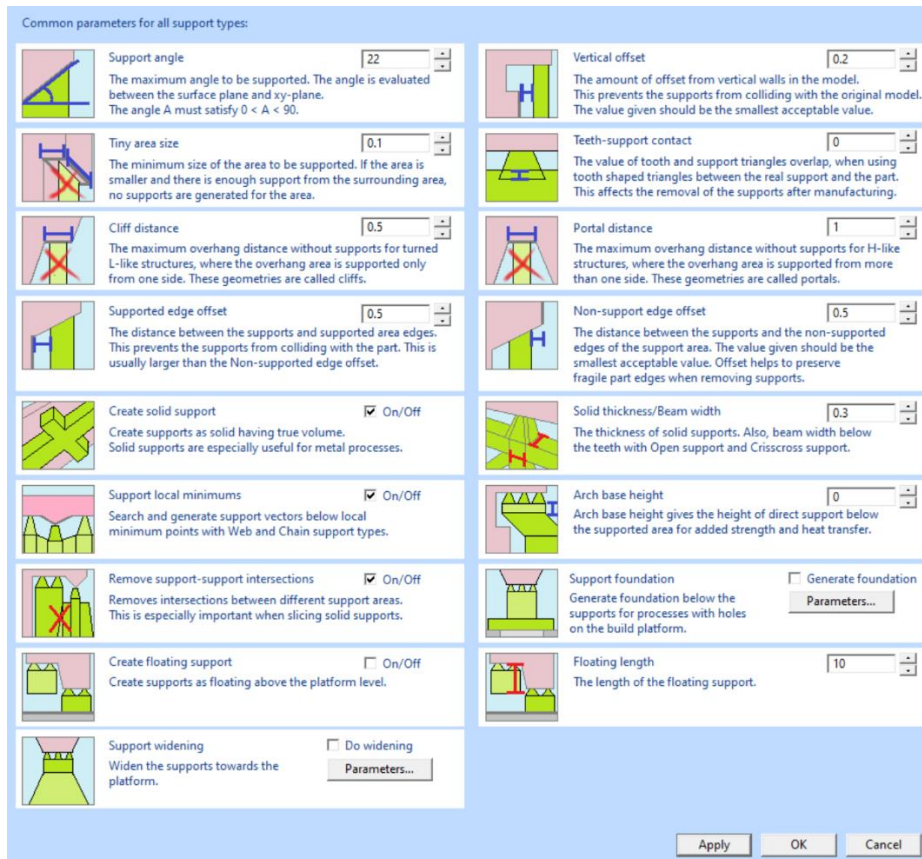

3Data Expert 16.0: Tutorial 4 - Generating Supports for AM

We will first demonstrate the effect of the most important *Common support* parameters. *Support angle* parameter defines which areas will be supported or not. If the angle between the surface and horizontal plane is bigger than the given angle, the part is considered self-supporting and no support is generated under the surface.

- **set the *Support angle* parameter to 45 degrees**

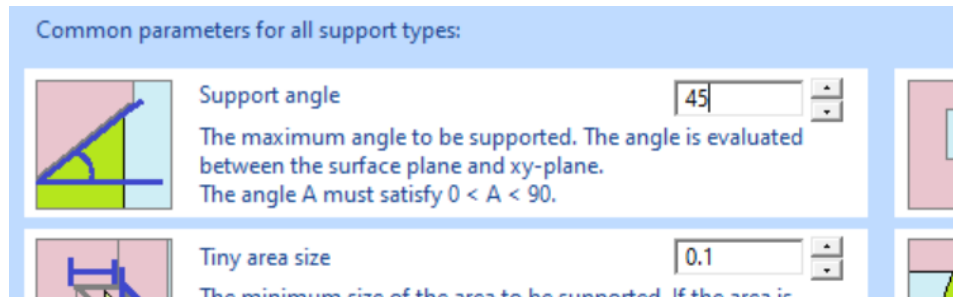

- **press the *Apply* button in the *Common parameters* dialog**
- **press *Yes* to the recreate request (if it appears):**

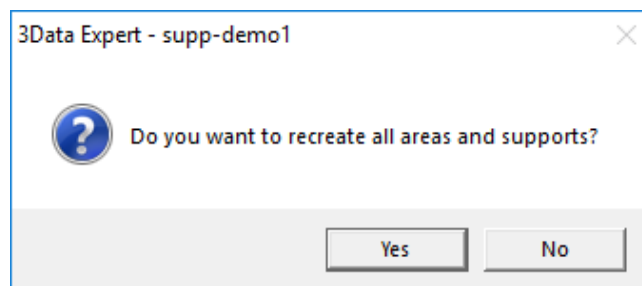

The result on the graphics changes immediately, as seen in the image below. The slanted area in the between the two horizontal areas is no longer considered self-supporting and it is added to support areas. Now there is just one large support area below the part. At least 45 degrees is a recommended support angle for most metal based AM processes.

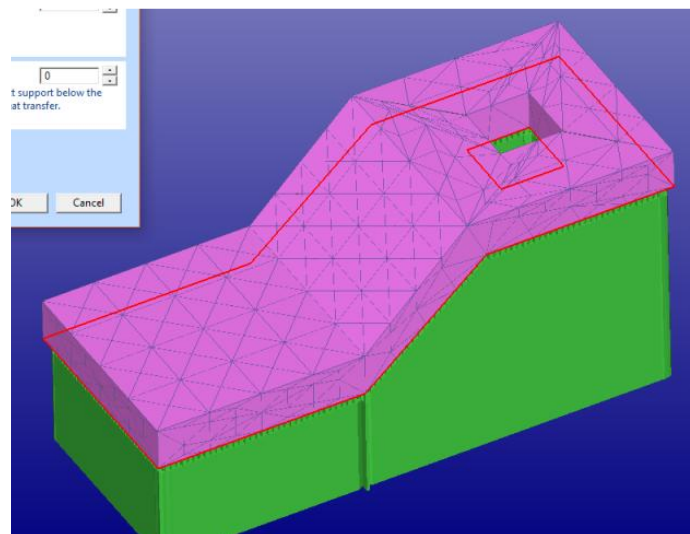

Now let's try the *Non-supported edge offset* parameter. This value defines how far the support following the area edge can be located from the outer edge of the support area. The default value is 0.5 mm,

- **change the *Non-supported edge offset* value to 1.0 mm**

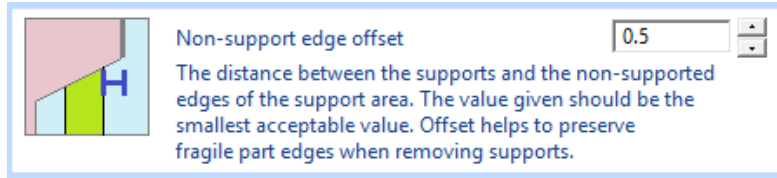

- **press *Apply* and *Yes* to the recreate request**

The support structure outer profile is now moved further away from the support area edge. In the left-hand image below we can see the 0.5 mm *Non-supported edge offset* result and on the right hand side the 1.0 mm offset. The edge offset value depends heavily on the receiving AM system, varying between 0.1 to 1.0 mm. Metal processes tend to require smaller values than other AM processes due to strong forces induced to the part during the cooling. If the support profile is too far from the edge, delamination or cracking may occur in the final part.

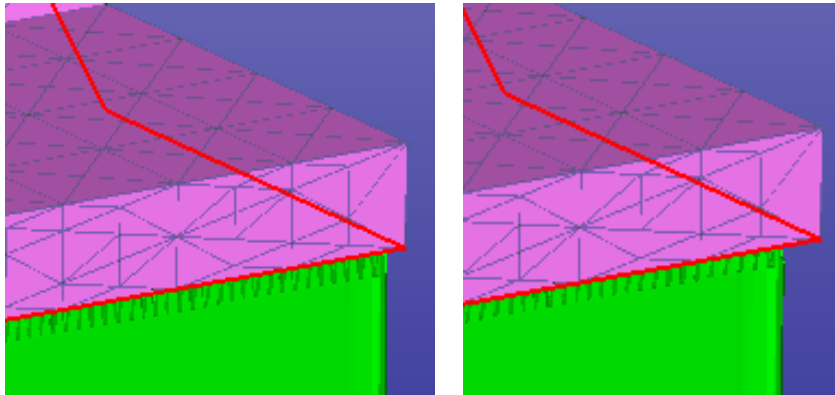

Finally, let's change all supports to open supports. By default, the supports generated with the default parameter set are solid, i.e., they form a watertight body. Some processes may not require solid supports and suffice with open support structure.

- **tick *Off* the *Create solid support* setting:**



- **press the *Apply* button**
- **press *Cancel* to the *Common parameters dialog* (do not risk modifying the Print configuration)**

- **press *Cancel*** to the *Support parameters dialog*
- **rotate the result** to see the open support structure as seen in the image below

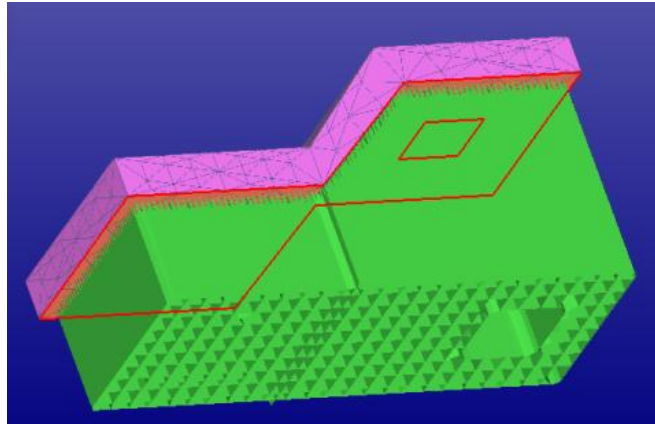

- **press *OK*** to *Create supports toolbar* to exit and store the supports to the Model Tree
- **if this warning dialog appears, choose *Yes***: we do not want to save the parameters this time

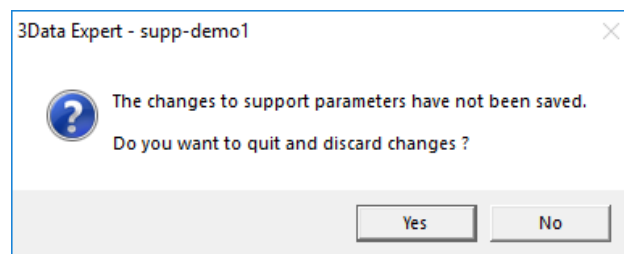

You will soon see the open support structure stored in the Model Tree.

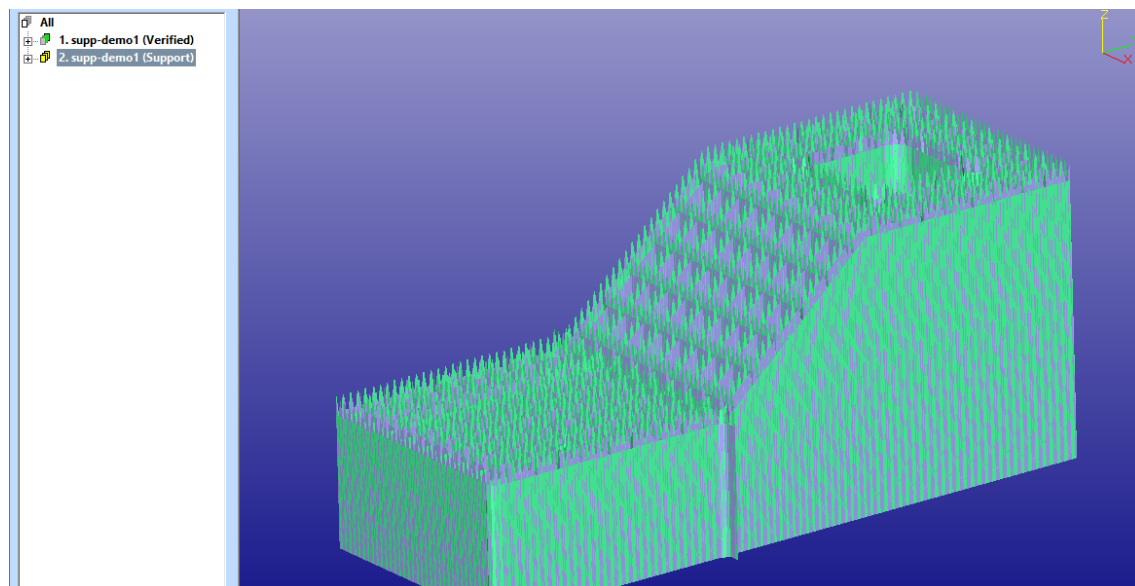

Editing Web support parameters

Web supports create a regular grid shaped support structure below the supported area. The grid size, thickness and teeth size can be tuned with the support parameter dialogs. Also, a profile which follows the support area edges at a given distance can be generated around the grid support structure. The latest version allows to convert Web and Chain supports into crisscross structure.

Now start again with the familiar supp-demo1.3de file. Once again,

- open the **supp-demo1** model and
- start **Generic Support** command
- press **Create** button in **Create supports** group
- **zoom into** the higher end of the support structures, make sure you have unobstructed view to the model higher support area (with a hole)
- **select the 2. support area** from the area list with **LMB**
- set **Create supports** setting to **Create supports for current area**, if not already set

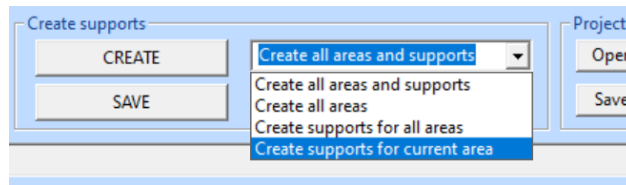

- press **Edit area parameters** button in the **Create supports** group
- press **Parameters** button in the **Web supports** group in the **Support parameters** dialog

Your screen should now look more or less as seen below, the model and supports on the right-hand side of the screen and support parameter dialogs on the left hand side of the screen. You can pan, zoom and rotate the view as necessary.



We will first modify the density of the Web support grid.

- **change the *X spacing* to 1 mm** (applies currently to Y spacing, too)

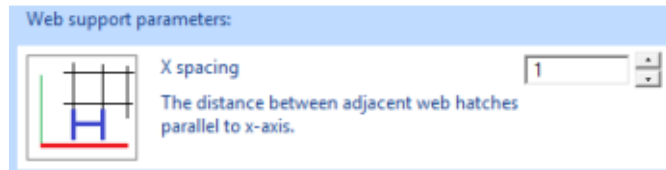

- **press the *Apply* button** in the bottom of the Web support parameter dialog

The support grid immediately becomes denser. The grid will now provide a stronger support, which may be necessary to avoid bending of the part or to dissipate heat from the part during the AM process.

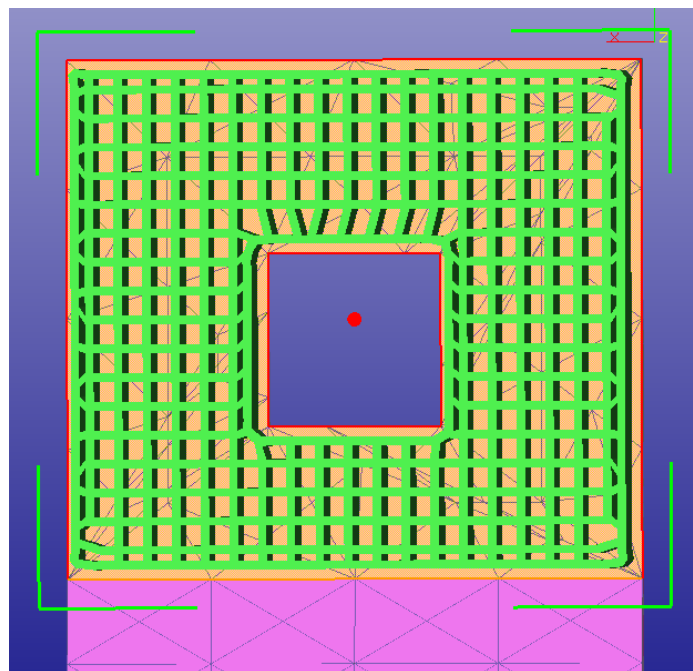

Let's next change the how the teeth intersect the part.

- **set *Up overlap* and *Down overlap* to 0.0 mm**

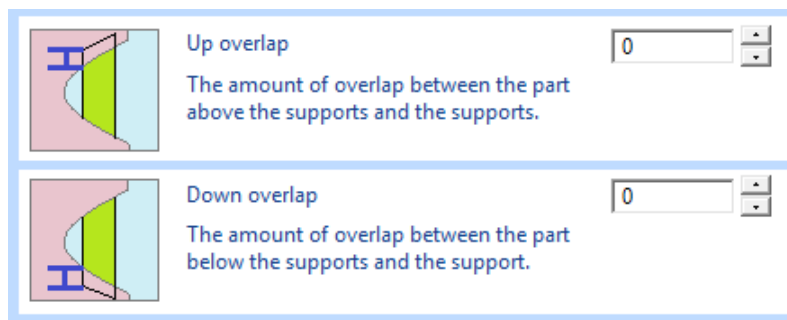

- **press the *Apply* button**

The support teeth do not anymore intersect the part surface. With some processes it may be necessary for the supports to intersect the part to get strong enough contact between the part and the supports. On the other hand, some processes may produce better result if the support just touch the surface, or even with small distance if overlap value is set to < 0.0 mm (i.e., a negative value).

In the left picture the overlap parameter has the default value, in the right one the overlap values are 0.0 (view from above, top of the model clipped off):

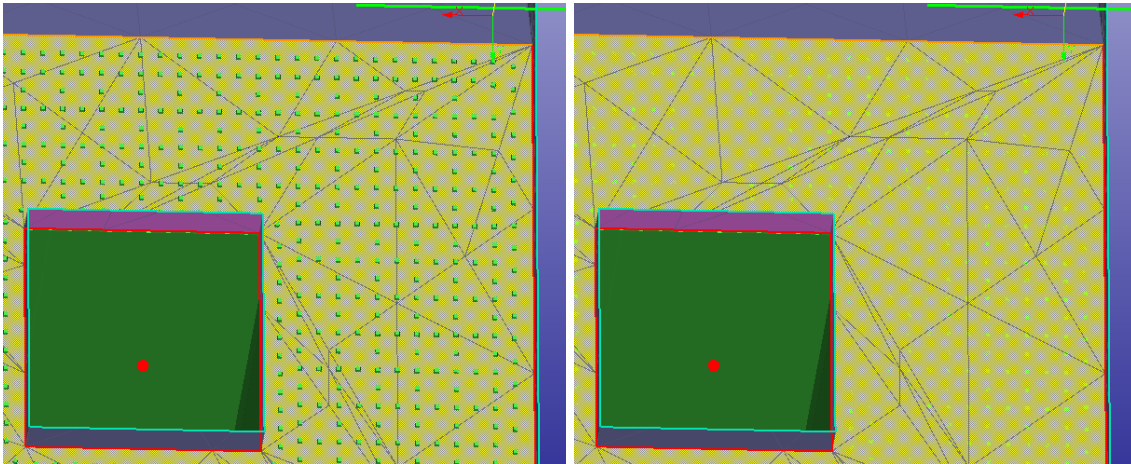

Let's now make a sparser grid with bigger teeth.

- first set the **X spacing** to **3 mm**
- then press **Apply** button in the **Web support parameters** dialog to update the grid
- then press the **Parameters** button in the **Tooth parameters** group

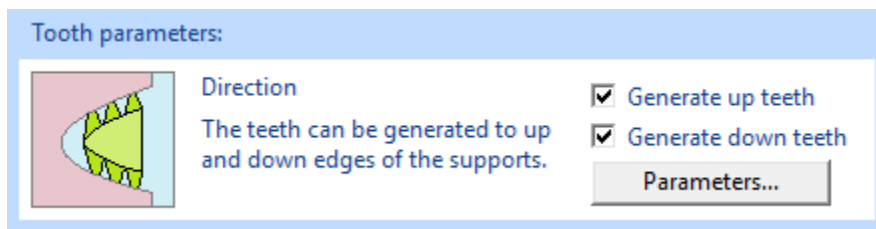

You should have the screen as shown below. The Tooth parameter dialog is visible and the sparser grid is shown on the graphics area.

Now fill in new values to teeth parameters.

- set **Teeth distance** to **0.5 mm**, as seen in the image below
- set **Teeth base length** to **0.5 mm**
- set **Teeth tip length** to **0.3 mm**
- set **Teeth height** to **2.0 mm**
- press **Apply** in the **Teeth support parameters** dialog

You should see updated teeth structure on the sparse grid structure. The software automatically calculates and modifies the most suitable teeth distance against the grid size and generates as dense teeth as possible. Zooming into the contact region, on the left before tooth parameter modifications, on the right with tooth parameter changes applied:

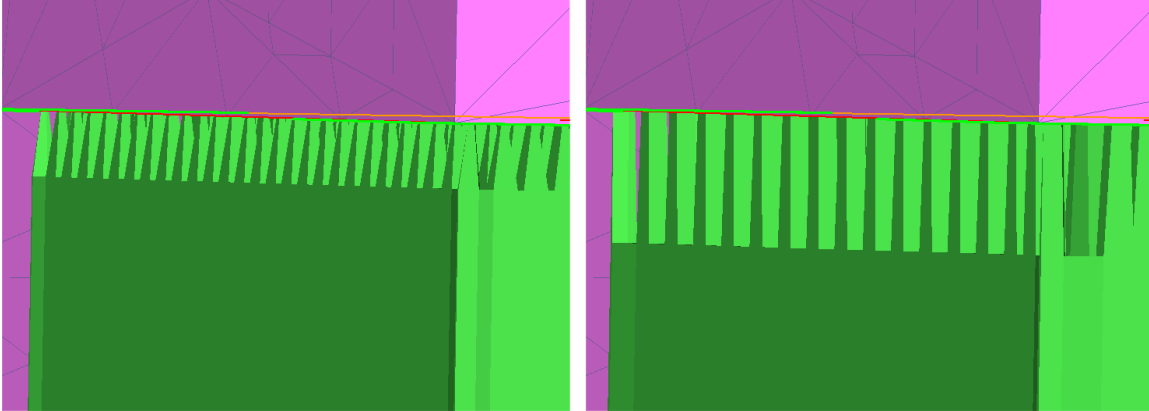

You can now exit all support parameter dialogs by pressing **Cancel**. This will prevent touching the Print configuration settings, but still store the modified parameters for the area 2. support area we selected when starting the parameter editing.

- **press *Cancel*** to Tooth support parameters dialog
- **press *Cancel*** to Web support parameters dialog
- **press *Cancel*** to Support parameters dialog
- **zoom and rotate** to see both support areas for the part

The two support areas now have different support structure parameters applied. In the start we selected the 2. *support area* and pressed the *Edit area parameters* button. All changes are now done only to the area 2. and the area 1. has remained in the original state.

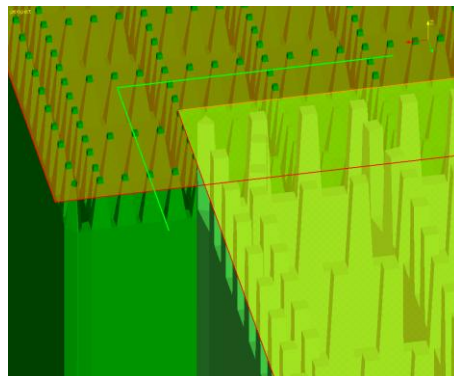

- **press *OK*** to save the supports into Model Tree. The result (clipped from positive X direction is shown in the picture below).

With 3Data Expert it is easy to define different support properties for different areas in the part.

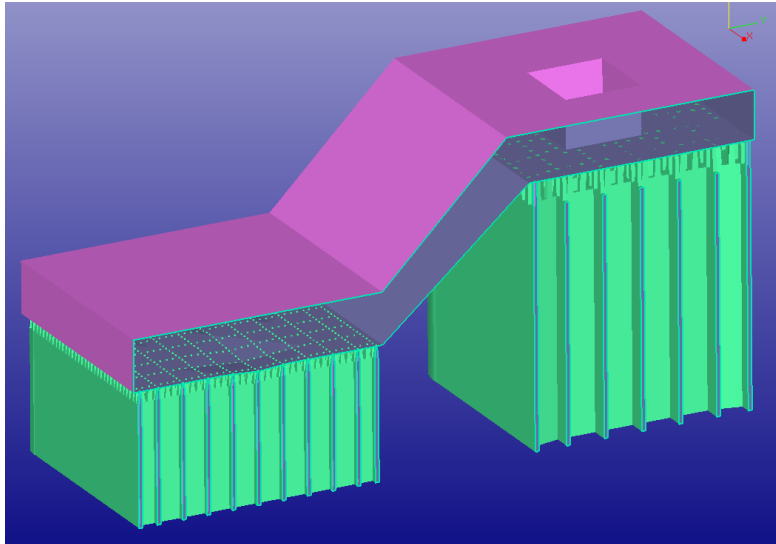

Note: You can also save the current support version to the Model Tree by pressing **Save** button in the Create supports dialog. This will not exit the support generation: it only stores the current supports in the Model Tree for subsequent comparisons. The saved result is named with “Sn:” prefix and made passive not to become visible. After exiting the support generation, you can make the saved support object visible with *RMB Make active* command.

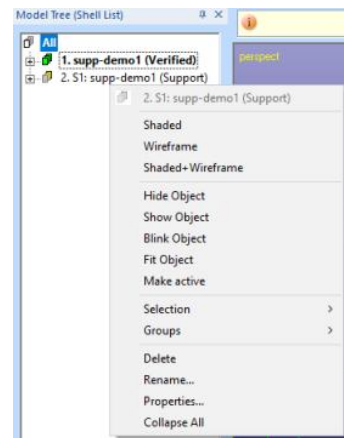

Editing Chain support parameters

Chain supports are used for supporting thin or sharp downfacing edges in the part. With the support parameters we can tune the tooth size and cross plate distance and cross plate distance from the support top.

To investigate the Chain support parameters, we will first generate a simple cube and rotate it for Chain support generation at the sharp downfacing edges. Also, we will Refine the box for some manual Chain support additions.

- empty the *Model Tree* with File > New command

- **create a box geometry with *Create Geometry > Box* command with the parameters below (20x20x20mm box):**

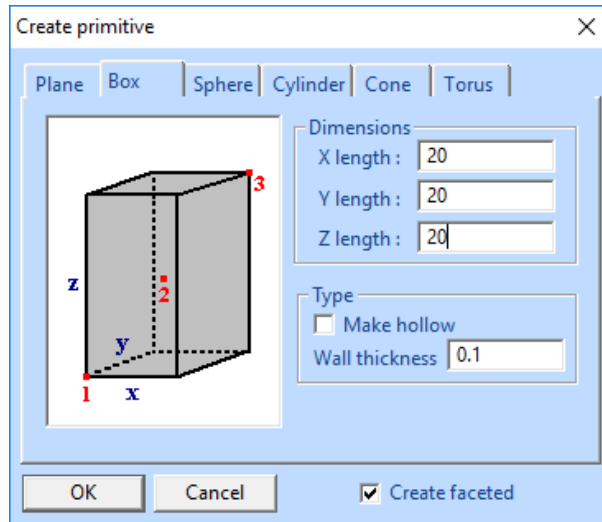

- **press *OK*** to create the box into the Model Tree
- **select the *Box Shell*** in the Model Tree
- **give command *Transform > Rotate > Numeric* to rotate 20 degrees around X axis, press *OK***

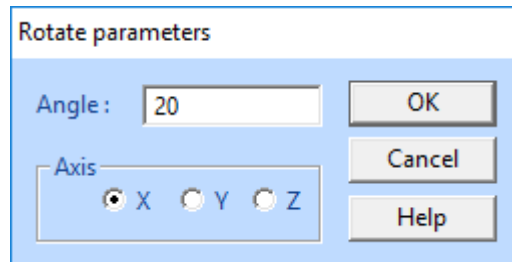

- **give command *Transform > Rotate > Numeric* to rotate 20 degrees around Y axis, press *OK***

You should have the following box in the Model Tree (viewed from Y axis direction):

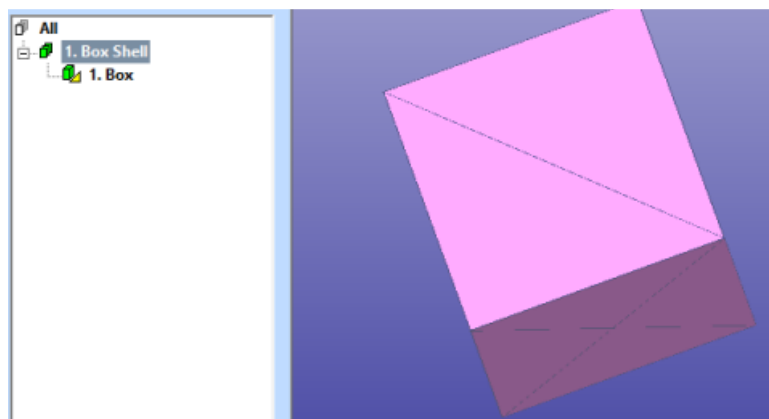

- move the part to the positive space with **Print Preparation > Move to Platform > Move positive** command using the parameters below

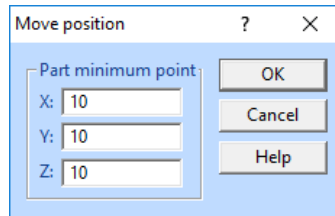

You should now have the box in the right place for support generation.

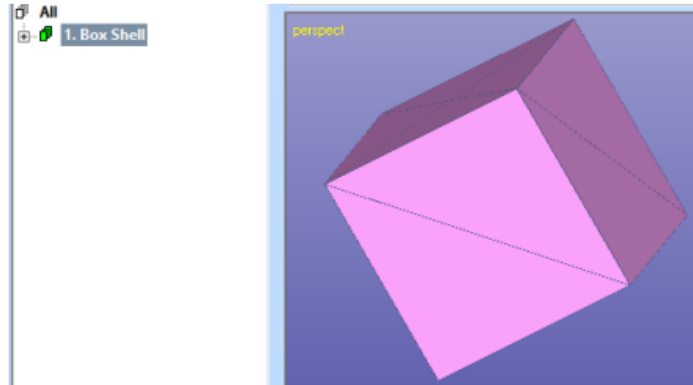

Let's now generate the *Chain supports* below the sharp edges of the box.

- select the **Box Shell** model in the Model Tree
- give command **Print Preparation > Supports > Generic Supports**
- press **Create** button in the *Create supports* group

You will see the support result in the support area list (one Chain support area) and in the graphics area:

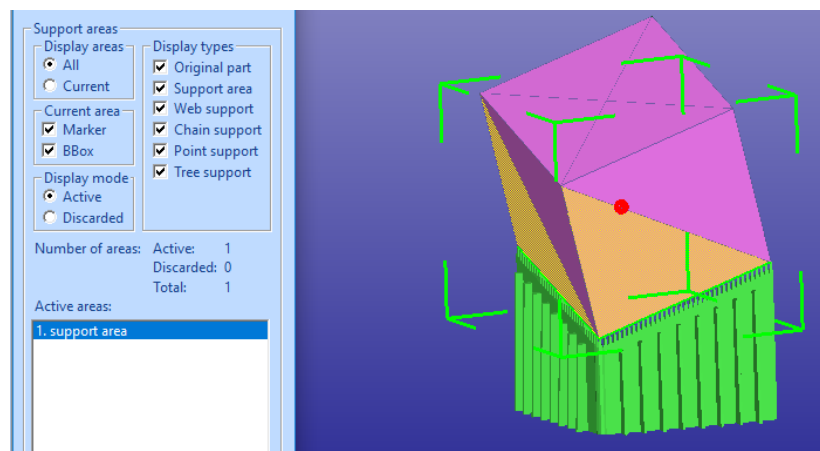

Before going to edit the *Chain support* parameters, let's add some stability to the build by adding manual support to the third slanted edge.

- now select the **Chain** type in the **New area group**,
- then press **Add support... button** to select two points from the box edge as seen below. Makes sure you select the points as close to the edge as possible. If you make a mistake, you can **Cancel** each step with the **ESC** key.

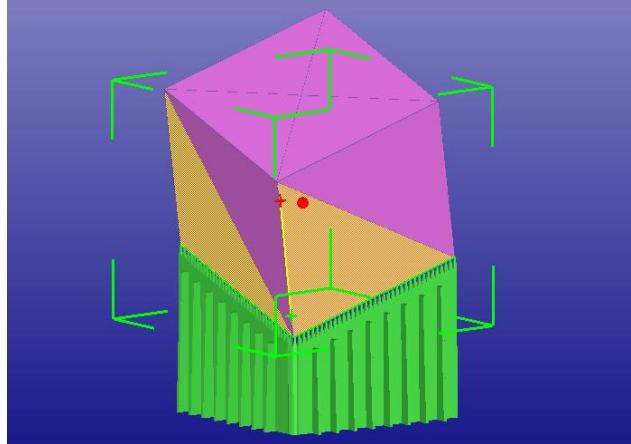

- when ready press **RMB** to save the new Chain area to the support area list and to generate the support geometry

Both areas are now regenerated, and the result is displayed on the screen.

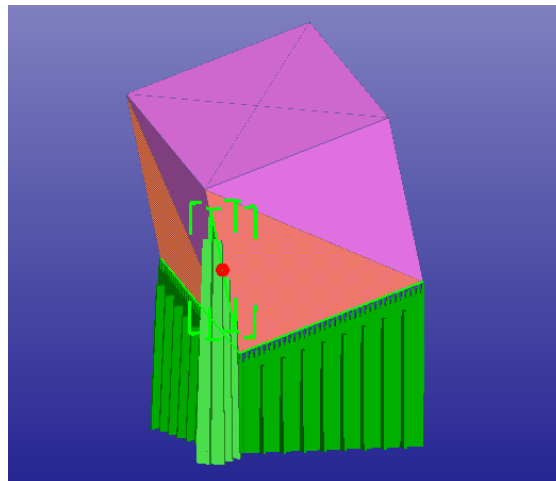

With this example we show how you can add more support to increase the stability of the part build.

Now rotate and zoom the model on the graphics area so that you will have an unobstructed view to at least one of the support areas. Then

- press the **Edit Parameters button** in the **Parameters** group to start editing parameters for all support areas at once
- press the **Parameters button** in the **Chain supports** group



- **change the value of the *Spacing* to 3 mm** in the *Chain support parameters* dialog

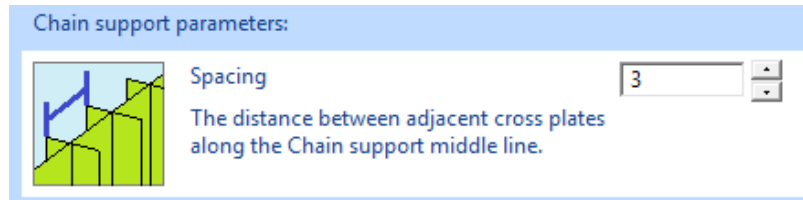

- **press *Apply*** in the bottom of the parameter dialog

The distance of the cross plates at the Chain support has increased. This parameter allows to create stronger (denser) or weaker (sparser) Chain supports, depending on the receiving AM process. Especially metal processes should have dense enough spacing to avoid support bending while creating them. Similarly, increasing the *Cross-length* parameter in the parameter dialog will add more stiffness to the supports.

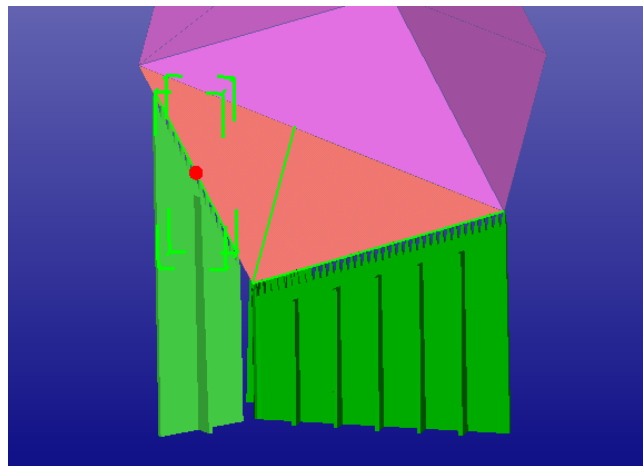

- **next change the *Distance from support top* value to 2 mm**

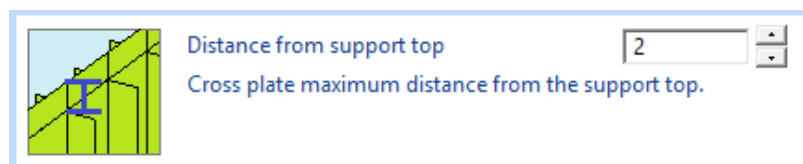

- **press *Apply***

The distance of the *Cross-plate top* is now increased.

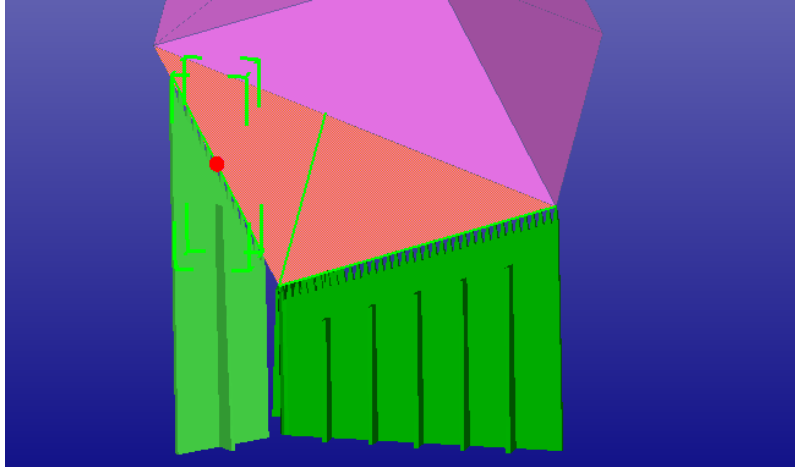

The value depends once again on the receiving AM process. Some processes can build higher (DLP, stereolithography) thin wall supports than some other processes (metal) without bending them. The smaller the distance from the top the stronger the support will be.

Up overlap, *Down overlap* and *Tooth* parameters work the same way as the corresponding support parameters with *Web support* type, described in the previous chapter.

Note: When you are adding the points for Chain support, make sure you always pick them from downfacing surfaces. Otherwise, the results may be unpredictable.

Close the support parameter windows with the **Cancel buttons**.

Editing Point support parameters

We could continue Point support parameter editing with the model created in the previous example for Chain supports. However, to have a refined triangulation of the cube

- **restart with supp-demo2.3de file**

You should have only the box in the Model Tree:

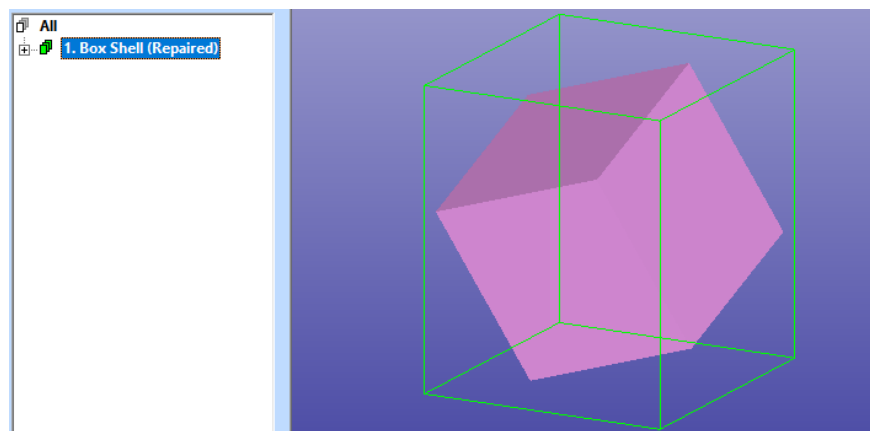

Start the support generation with the Generic Support command

- give command **Print Preparation > Supports > Generic supports**
- open the **Support parameters** dialog via **Edit parameters** button in the **Create supports toolbar**
- press **Common parameters** button in the **Support parameters** dialog
- edit **Support angle** parameter to value **10 degrees**

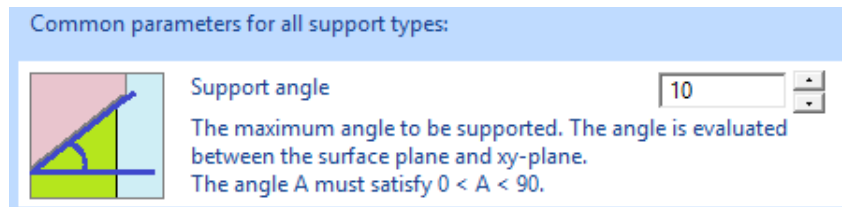

- press **Apply** button in the bottom of the **Common parameters dialog**

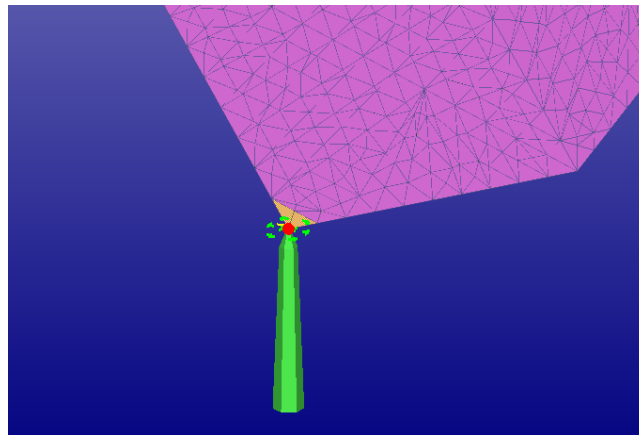

You will now see a single *Point support* below the Box Shell. Due to the *10-degree Support angle*, no other area below the Box Shell is considered to need supports this time.

We will now go through some basic *Point support* parameters.

- press **Cancel** to close the **Common support parameters** dialog
- in the **Create supports** window, choose **Create supports for current area**
- press the **Edit area parameters** button (to modify current area only)
- press the **Parameters** button in the **Point supports** group

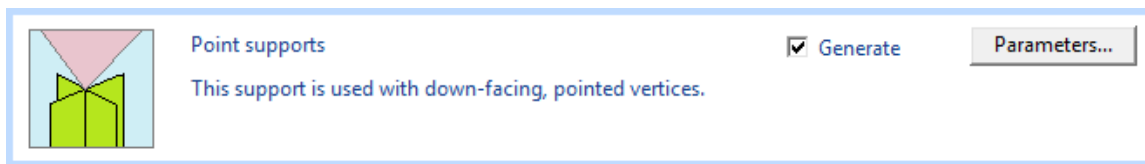

- first change the number of **Plates** parameter to **6**

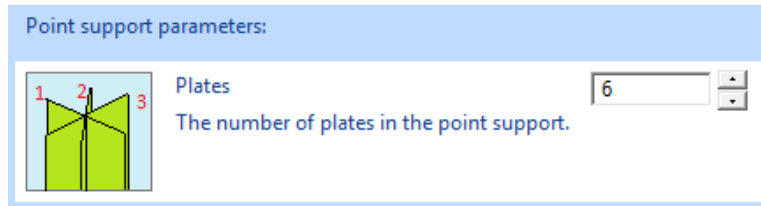

- press the **Apply** button

You will see the Point support shape to change in the graphics area. In the right-hand image we you can see the original Point support with 3 plates. Because the *Solid supports* in *On* in the *Common support parameters* the support is a solid tube instead of three open plates crossing each other. When we increase the number of Plates, the point support tube becomes smoother due to more plates, i.e, the subdivision of the tube outer surface becomes more accurate.

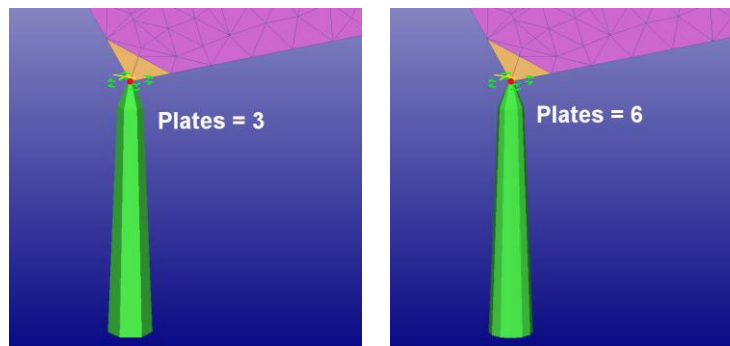

- now change the **Plate length** to **3mm**
- press the **Apply** button

The Point support is now 3 mm in diameter:

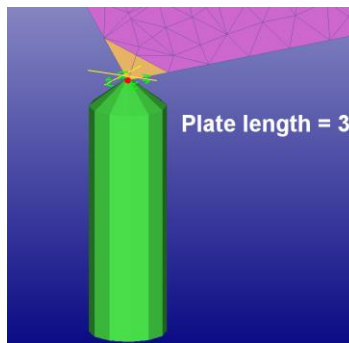

- next turn **Off** *Generate up teeth* and *Generate down teeth*

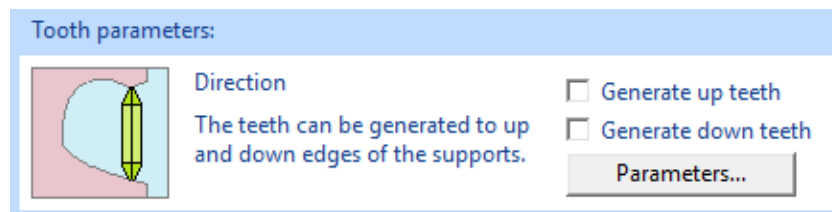

- **press the *Apply* button**

You will see the tooth on top of the Point support disappear, as seen in the image below.

Tooth parameters, Up overlap and Down overlap parameters work in the same fashion as was described in the *Web support* parameter editing chapter previously.

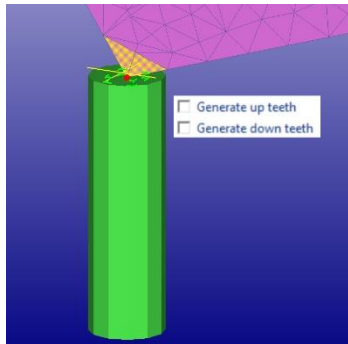

- **Close the parameter windows with the *Cancel* button.**
- **Exit support generation with *Cancel***
- **Close the model: *File > Close***

Generating Tube supports

Tube supports allow you to convert the Web, Chain and Point supports to small tubes. This kind of supports have several uses, like supporting teeth implants for medical applications.

Start again with the original *supp-demo1.3de* file. Once again,

- **open the *supp-demo1* model and**
- **give the *Generic Support* command**
- **press the *Create* button in *Create supports* group**

You will soon see the familiar support structure on the graphics area:

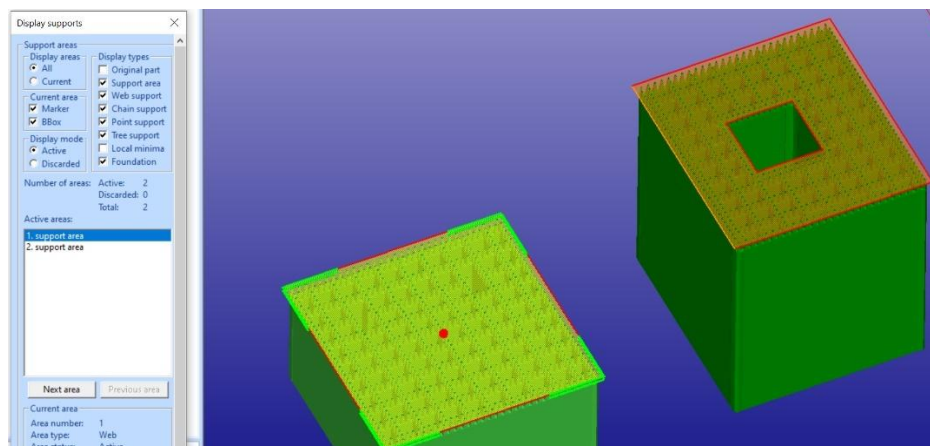

- Press the **Edit Parameters** button
- Tick **On the Generate** selection in the **Tube supports** group at the bottom of the dialog

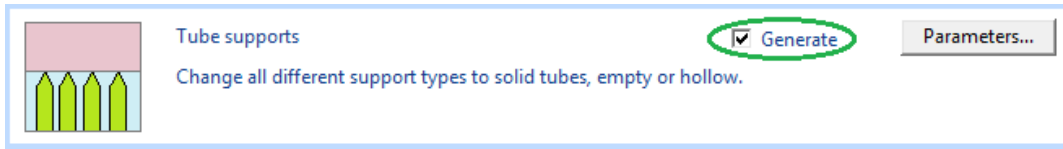

- Press **Apply** in the **Support parameters** dialog

Soon you will see the Web, Chain and Point supports changed to tube like structures, as seen in the image below. The Tubes are generated more or less to the same locations where the teeth to the first support were located. The Tubes are disconnected from each other and also stretched to the vat bottom. On the right we see the tube supports (with web supports on the left, for comparison):

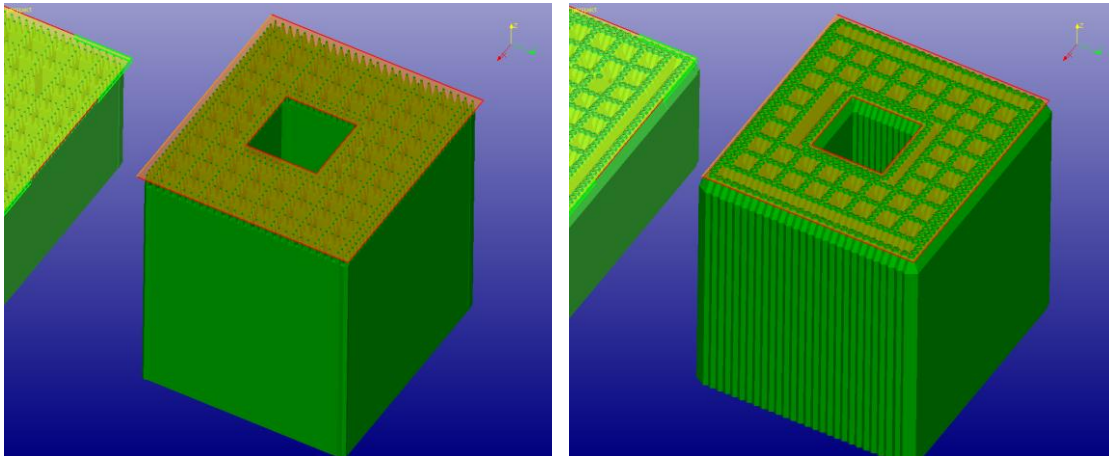

The tube parameters are set though the *Parameters* button in the *Tube supports* group. The parameters allow you to change the *Tube wall thickness*, *Tube smoothness*, and *Tube top and bottom size parameters*, as seen in the image below. If the *Tube thickness* is set to 0, a solid tube is generated (closed at both ends).

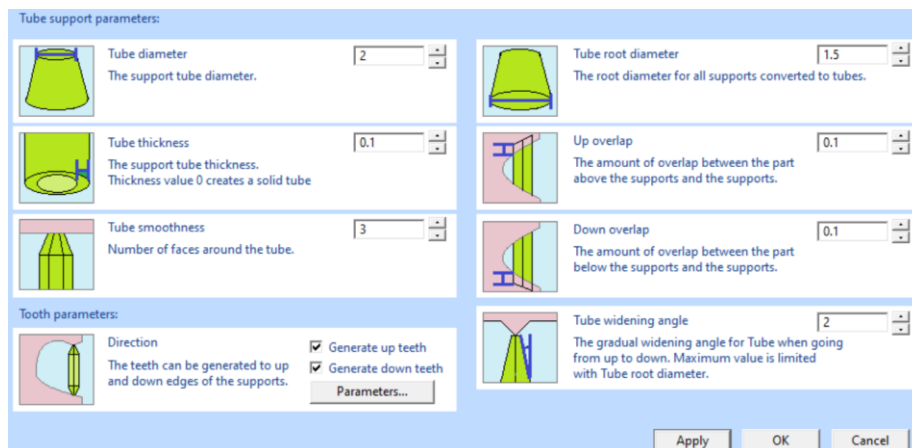

3Data Expert 16.0: Tutorial 4 - Generating Supports for AM

The Tube diameter and distance is set according to the teeth size defined for the Web supports. Teeth base length will define the diameter of the tube and Web supports Teeth distance will define the average distance between tubes (the distance value is modified to fit the optimal number of teeth between the Web grid points and the Profile edge points). You must be careful not to use too big a *Tube thickness* when compared to the *Diameter = Teeth base length* or *Top/Bottom diameter*, otherwise you might generate self-intersecting support structures.

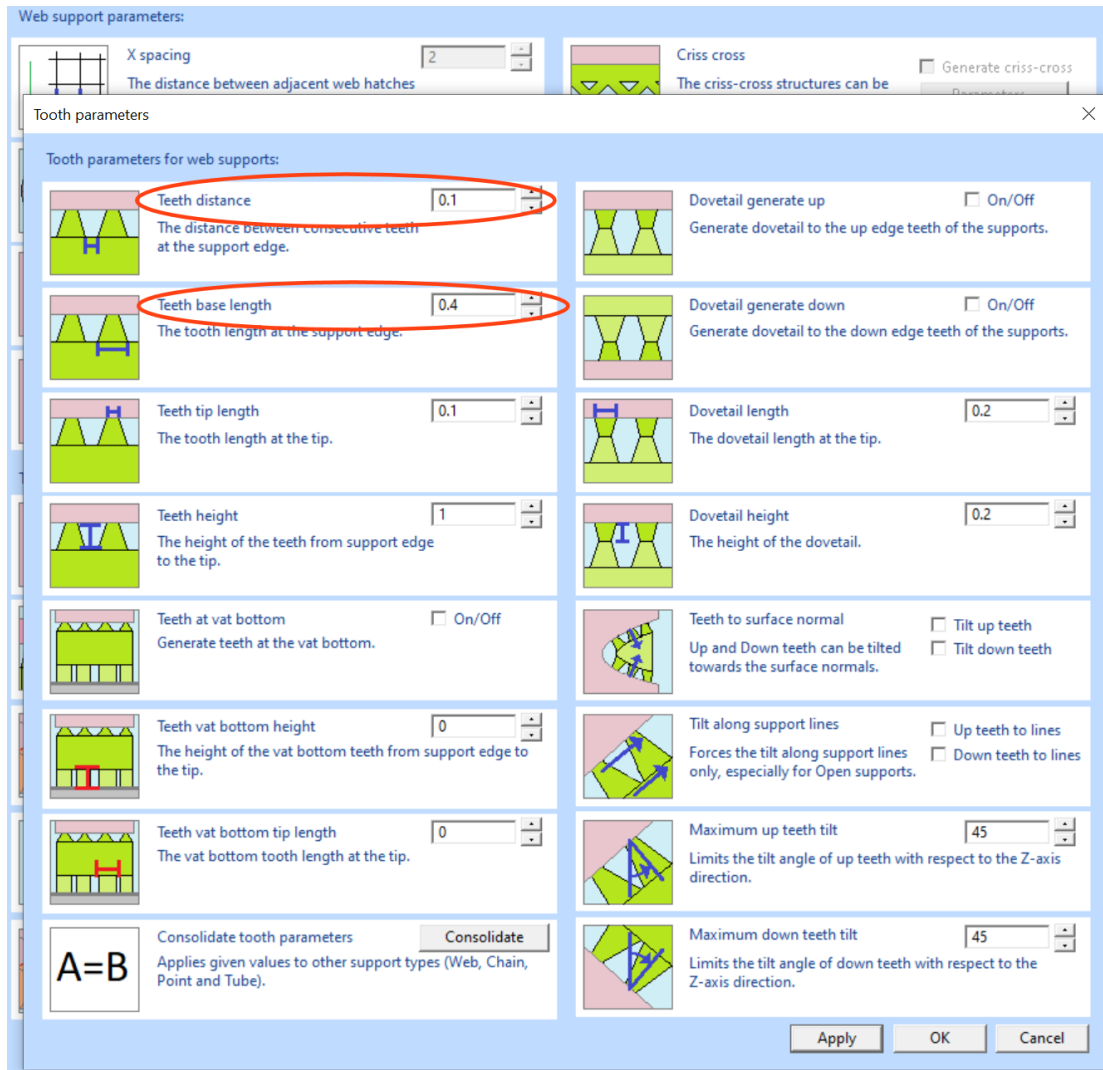

You may now start again the Tube support generation and change the different values to see how it affects the generated Tube supports.

- Finally, **Close the parameter windows** with the **Cancel** button, to keep the Print configuration setup intact. If you use the **Ok** button to close the windows, you can still bypass the Print configuration modification, when asked.

- **When ready, press *OK*** to the *Create supports toolbar* to save the tube supports into the Model Tree

Compact parameters dialog

You can use the *compact Support parameters* dialog when you get more familiar with the system and its parameters, or if you have a low-resolution display. With the compact Support parameter dialog less graphics area is covered, and 3D models can be more easily viewed.

The Compact Support parameters dialog is used when **Use compact dial** is *On*.

Create supports

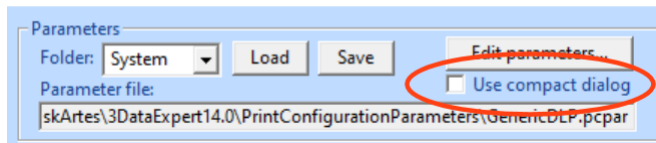

In the image right the X spacing is selected for editing. When a parameter is selected in the dialog, the lower window shows the explanation text as well as the parameter image.

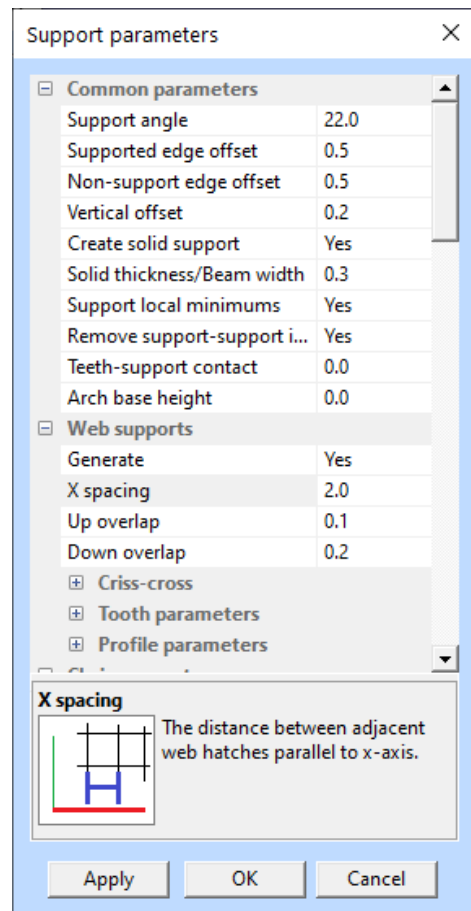

Generic Support improvements with version 14.0

Generally, there have been several improvements in the Generic Support command internal functionality: better area filtering, vertical wall separation, smoother profile edges etc. Additionally, some new functionality has been added:

Helical area supports

Helical parts and areas can now be supported normally without splitting the area in two.

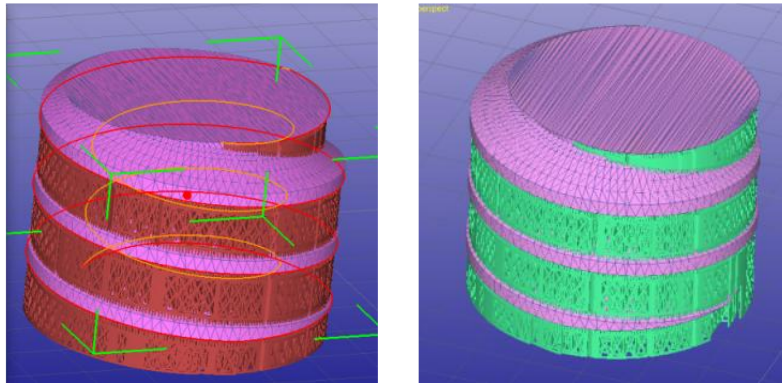

Move details end point re-evaluation

The Move details command in Edit Supports dialog has been improved. The support point selection is now less crowded and an option to re-evaluate the end points of the moved support point has been added. In the left-hand image below the available selection points area show with green crosses. In the right-hand image the new *Re-eval end pts* parameter is shown.

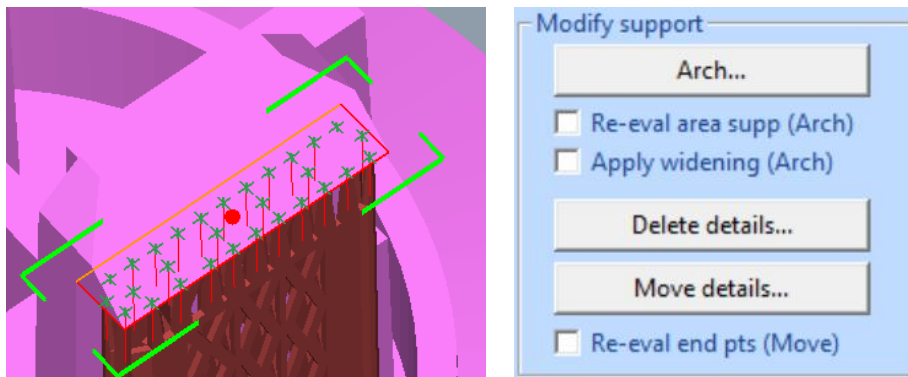

The effect of re-evaluating the end points is shown below. The automatic support generation produces the result in the leftmost image below. The support goes along the vertical support at the bottom of the image. To create better surface quality the support point at the area border can be moved manually. The middle image shows the movement without re-evaluating the moved support vector end points. Some overlapping of the supports and the part remain in the lower areas.

When the *Re-eval end pts* is used (in the right-hand side picture) the support does not affect the vertical surface in the bottom anymore.

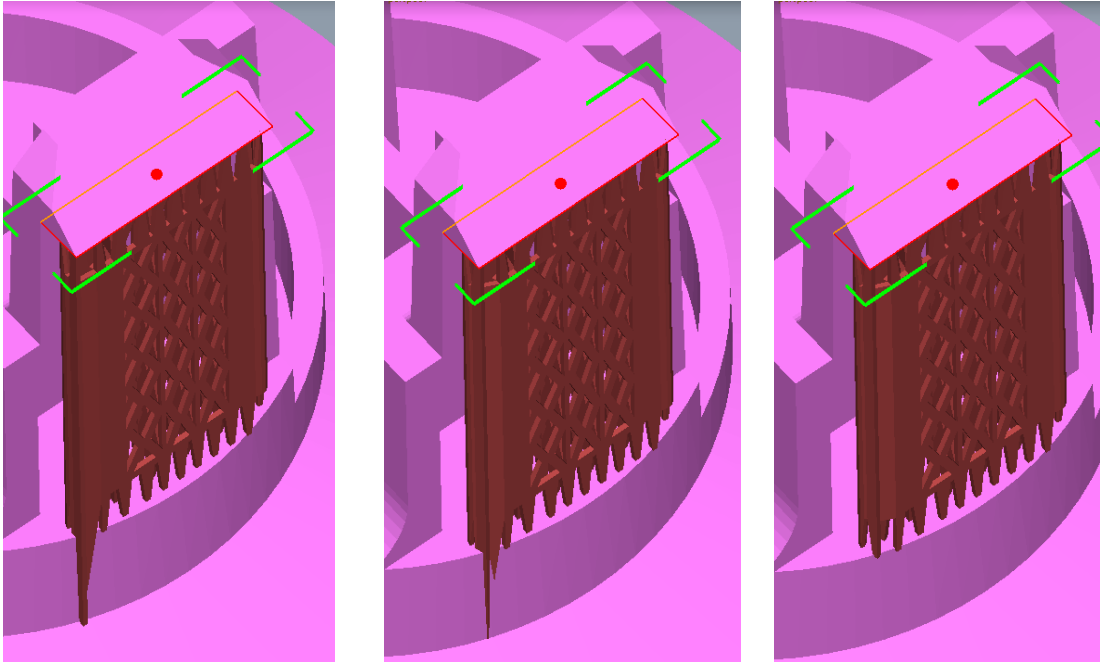

Similarly, with the *Arch support* modification, the original support geometry is used by default. This enables you to delete some details from the support and then perform the Arch operation and keep the modified support geometry. If *Re-eval area supp (Arch)* is set, all support vectors are re-evaluated during the Arch generation and previous edits are lost.

More consistent support geometry

There are less “stray” single point supports and the supports are generally smoother and better connected than with previous versions. This will help to keep the used material clean and allow better reuse of the material.

In the image below we have version 12.0 solid supports on the left and new 14.0 solid supports on the right-hand image:

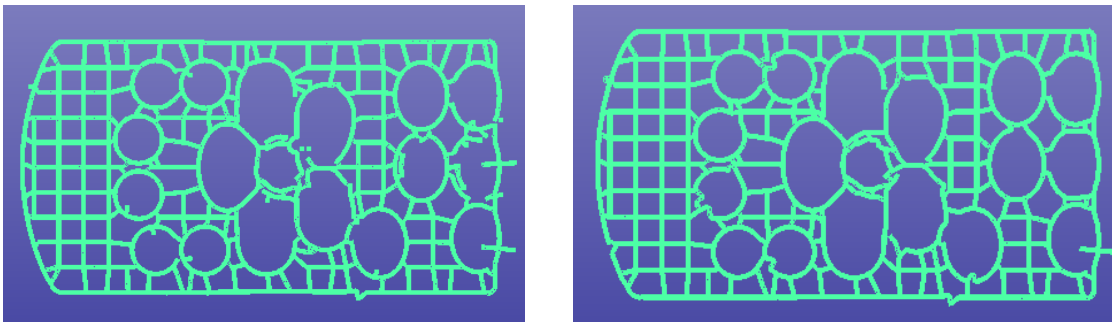

The same applies to open support structures, less stray components in the supports. Version 12.0 on the left and 14.0 on the right-hand side image:

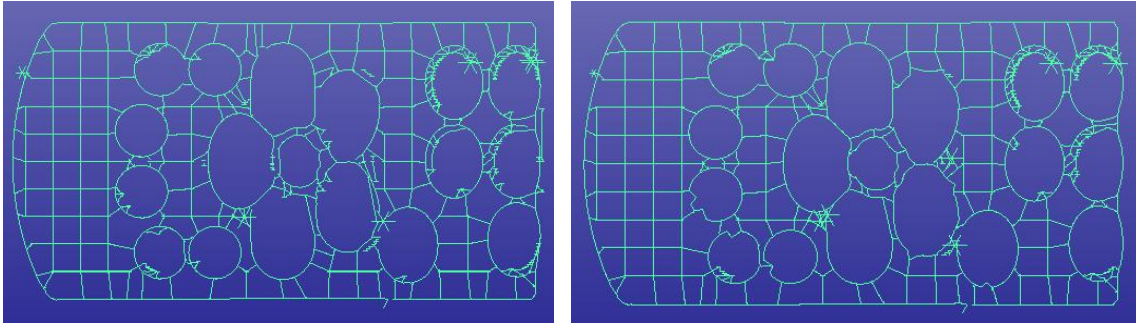

Lesson 4 - Outputting and slicing supports for AM

There are two ways to output the generated supports for AM. Either both the part and the supports can be stored as STL files on the hard disk, or they can be sliced and outputted as slice files for AM. Current slice file output formats include .cli and .sli (EOS format). Slices can also be saved as bitmap files, as explained later.

Saving supports STL file

The STL file output is simply done with *Edit > File Save As* command. You can either save the part and the supports separately, one at a time, or they can be saved at once. The two methods need slightly different settings.

Saving STL files separately

- In *File > File Options*, set the Common and STL save options according to the picture on the right.
- Select the part in the Model Tree:

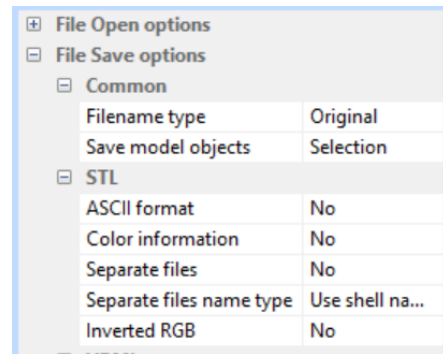
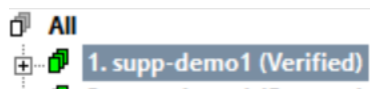

- Start *File > Save As*. Set STL as the output file type. Note that the default file name only contains the *supp-demo1* part of the shell name. Feel free to use a different file name.

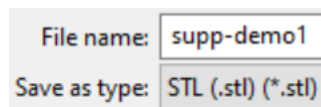

- Select the supports shell:

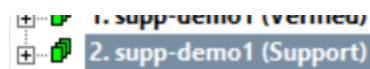

- Start *File > Save As*. Note that the file name now contains the *s_* prefix (as specified in *Edit > Preferences > Supports*), to distinguish it from the part file:

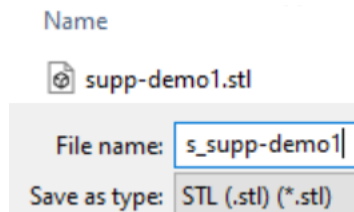

Saving STL files together

- In *File > File Options*, set *Separate files* to **Yes** and *Separate files name type* to **Add index** (as shown in the picture to the right).

- Select the root level *All* in the Model Tree:

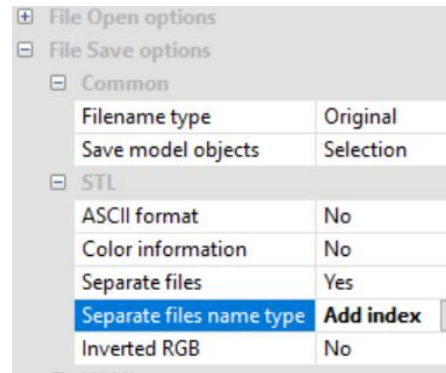
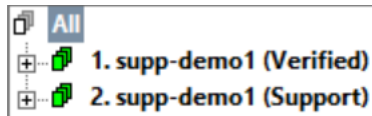

- Start *File > Save As*. During file save, answer **Yes** to the question:

The output selection contains both model and support data.

Continue File Save?

- We will get the following output files:

Name	Size
supp-demo1-0.stl	40 KB
supp-demo1-1.stl	11 528 KB

The STL files can later be given to AM system software for slice generation.

Saving support and part slices

Both the part and the supports can be sliced in 3Data Expert and then sent to the receiving AM system software. This involves the use of two different commands, *Print Preparation > Slices* and *Print Preparation > Fix Slices* commands.

If you do not have a supported model available, please generate the supports to the automatically as shown in the Chapter 2. After the supports are generated, slicing is started by selecting the part to be sliced in the Model Tree:

- **Multi-select 1. *Supp-demo1 (Verified)* and *supp-demo1 (Support)*** in the Model Tree

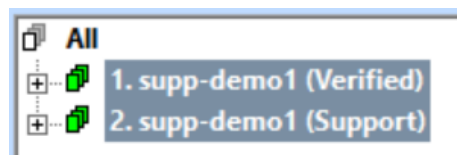

- **give command *Print Preparation > Slices*** and a parameter dialog appears. Use the default values (retrieved from the Print configuration), but in *Advanced* section, set *Output to disk* off:

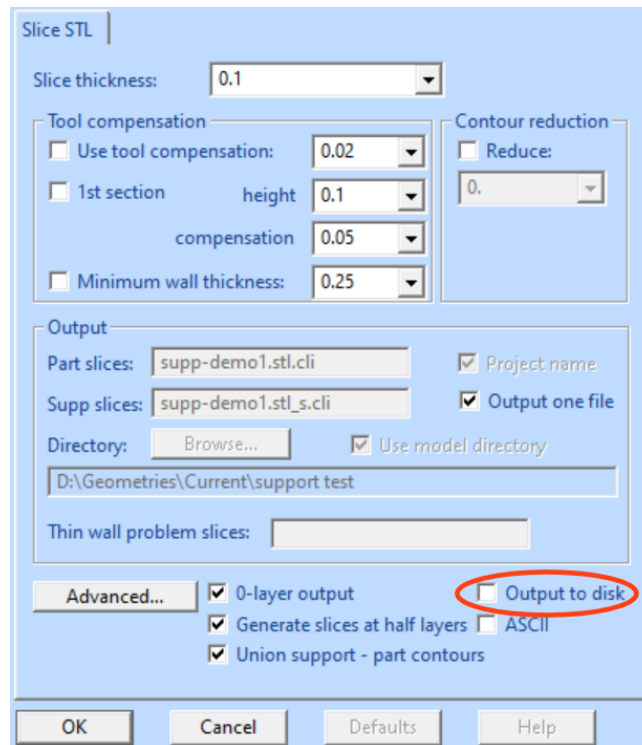

- **press OK** to start the slicing

After a while the slices are displayed with the graphics area using the Slice Preview toolbar; the lowest-level slice is drawn in the preview. Both part and support slices are now in the last shell in the Model Tree.

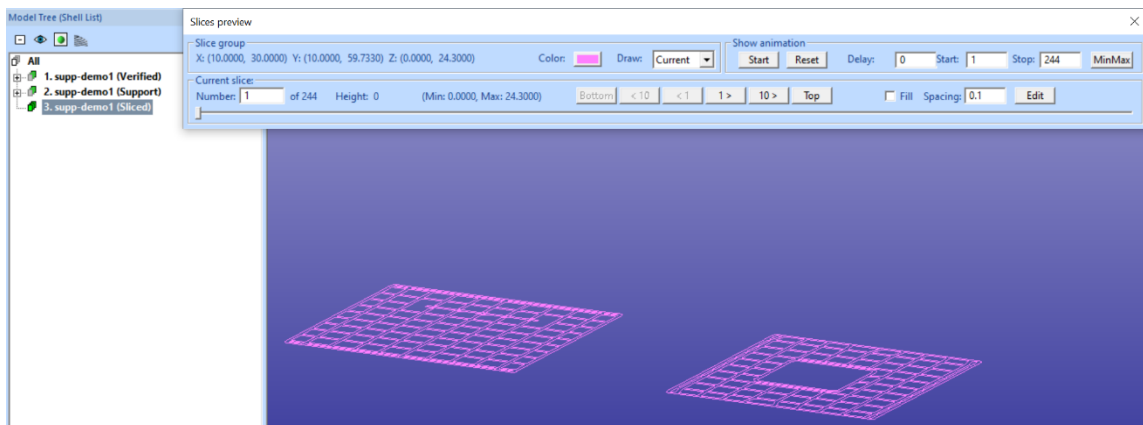

We have generated slices for both the part and the support with slice thickness 0.1 mm. You can preview the slices using the Slice preview toolbar commands: Change the color of the slices, use the horizontal slider to manually go through the slices, *Show animation* to see all slices automatically and go to a specific slice level with *Current slice* group settings.

3Data Expert 16.0: Tutorial 4 - Generating Supports for AM

Visual checking shows that the slices are ok and should be ready for output to AM processes, as seen in the picture below. We have selected both slices for display at once, and 0.1 mm filling to ensure that the contours are closed.

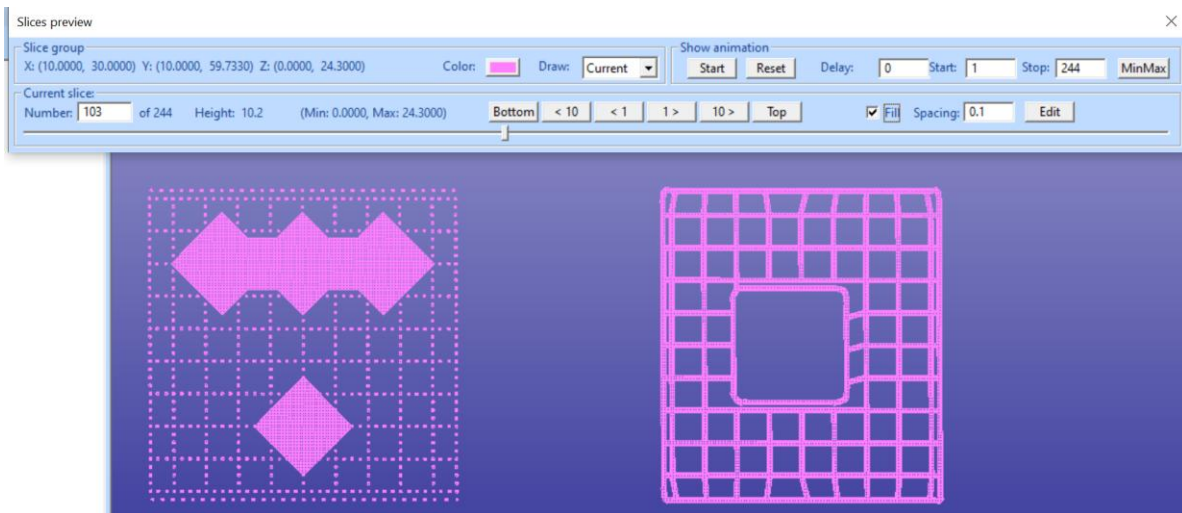

You can now close the Slice preview toolbar with the upper right hand corner Close icon.

Originally, we have generated solid supports with the default Print configuration settings, which produces solid support data. For this reason, we may want to make sure that all slices form closed polygons too. This is checked and fixed with Print Preparation > Fix Slices command. This will fix both the part slices and the support slices.

- **select the slice shell** in the Model Tree
- **give command *Print Preparation* > *Fix slices*** and parameter dialog appears

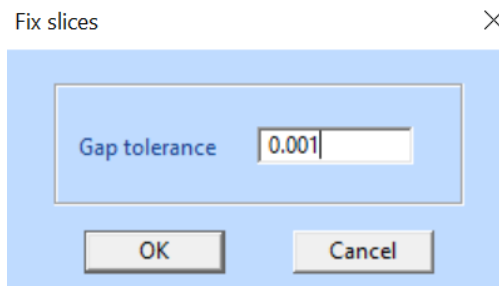

- **accept the default tolerance and press OK**

You are now ready to output the slice data for AM. There are two ways to store the data, either as **contour data** (.cli, .sli) or as **bitmap data** (as BMP, JPEG or PNG files).

The **contour data** is saved simply by using the *Edit > File Save As* command. Select each slice shell separately and output them in the suitable slice format, CLI or SLI (EOS format). Remember to name the part and support slice files so that they can be separated from each other, like part.sli and part_s.sli, where “_s” suffix depicts the support slice data.

For **bitmap output** you need to generate separate bitmap file. This is done with *Print Preparation > Export slice bitmaps* command. When the command is given, the *Slice Image Export* dialog appears:

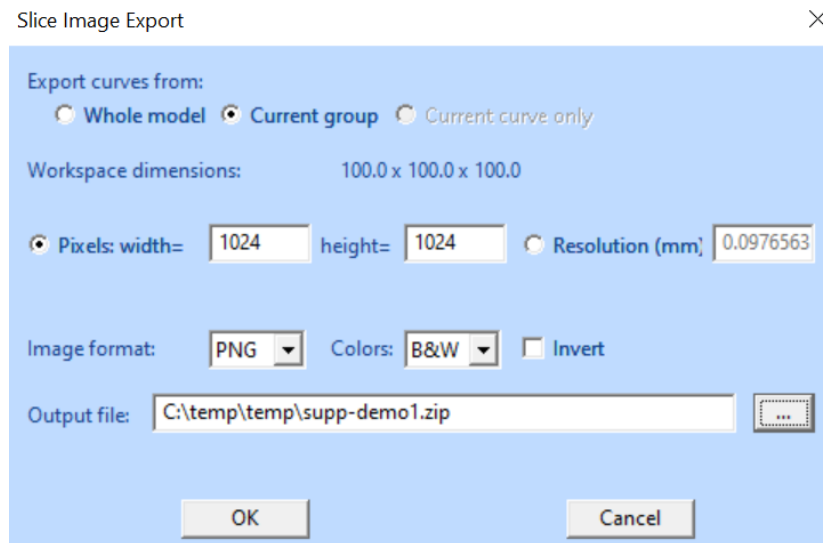

With the dialog you can set several properties of the output data. You should normally use the default parameter values (taken from the Print configuration), but the output can be tuned, for example if the files will be prepared for a different AM system:

- **Output *Whole model* vs. *Current Group*.** Normally you will select *Whole model* to output both part and support slices into the same ZIP file
- By default, output image size is set either directly or via resolution (as defined in the Print configuration), but you can change the method
- Select image type PNG, JPEG or BMP (note that JPEG option can cause compression artifacts in the output images)
- Select black and white (one bit per pixel), RGB (24 bits per pixel) or grayscale (8 bits per pixel) images
- Invert inside vs. outside color (dark inside/white outside or the opposite)

Select the output directory and output ZIP file name. Then press OK, and the slices will be stored into the given directory and file:

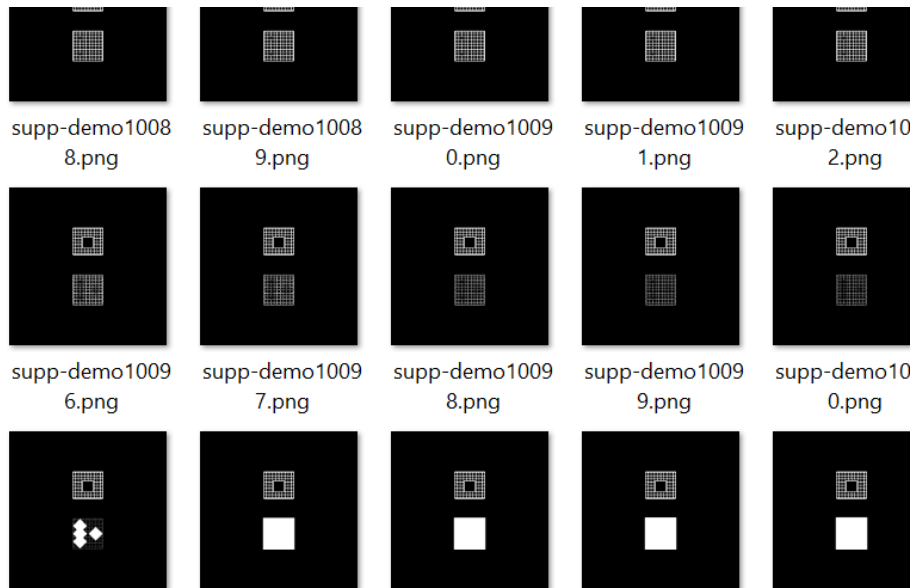

The preview images of the slices above show the support as a web like structure and the part as solid white area, as seen in these details of two non-consecutive slice bitmap files:

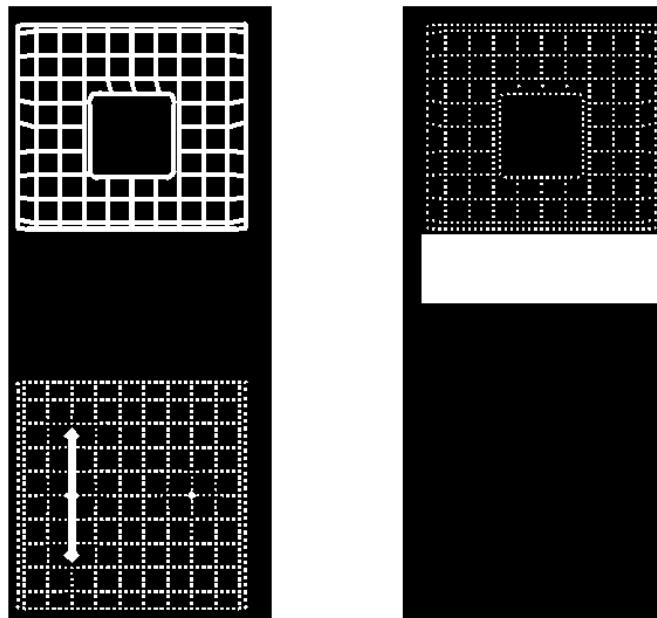

Slicing supports and parts into one file

With earlier 3Data Expert versions it was necessary to merge all part and support shells into one shell before the *Print Preparation > Slices* command if both part and support slices had to be stored in a single file. 3Data Expert 16.0 allows slicing of several part and support shells at once into the same slice file. Actually, it is

3Data Expert 16.0: Tutorial 4 - Generating Supports for AM

recommended not to merge the components as that would remove the Label text string attached to the separate shells for Production Screenshot, for example.

First load the Print Configuration file *GenericDLP-modified.pcp* (saved in Tutorial 1) to get a workspace suitable for our example model.

We will start with the *12-cellphones.3de* file (no need to move the model this time):

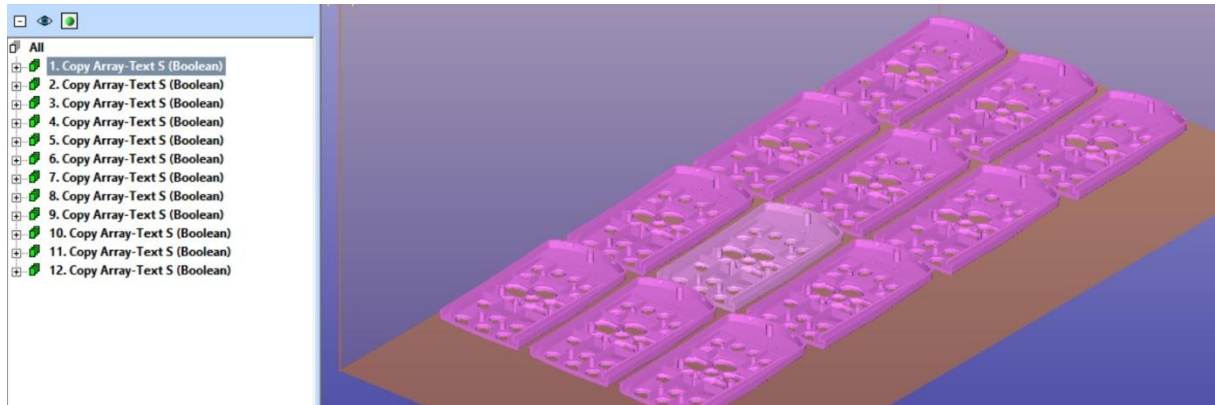

If you wish, you can turn on/off the platform display with the  icon.

We will first create supports to the cellphone models.

- Select Model Tree root All
- **Create supports with Generic Support** command (if in doubt of parameter state, you can reload the Print configuration):
- **Press OK** to save the supports into the Model Tree
- After a couple of minutes you will have all the supports checked and verified in one shell of the Model Tree:

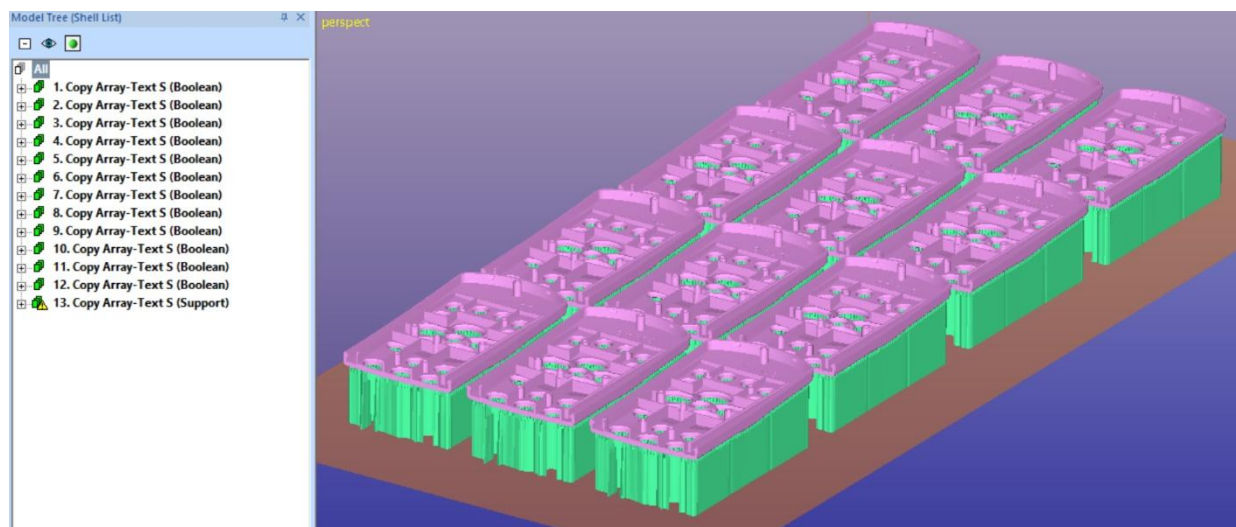

Now you can

- **first select root All** and Slice all components at once.

- give command **Print Preparation > Slices**.

You probably get two consecutive warning messages (shown below). The software first tells that the supports shell is in warning state, then that the numbers of part and support shells selected differ. This is correct because we have generated all supports at once to all separate parts earlier.

- press **Yes to both questions**:

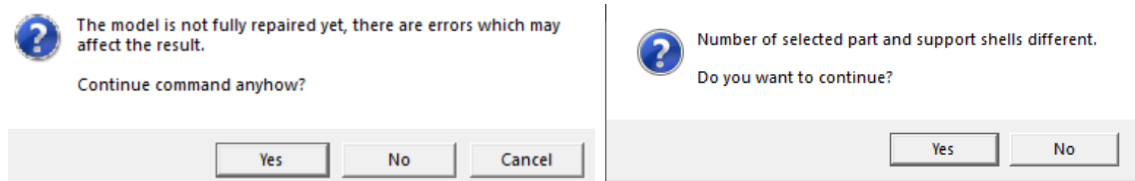

Finally we will see the Slice STL dialog. This time we choose a slightly different set of parameters:

- Turn on *Output one file*
- Turn off *Use model directory*
- Choose a different output *Directory* (use the *Browse...* button), unless you want to save the slices into the tutorials folder
- In the *Advanced* section, turn on *Output to disk*

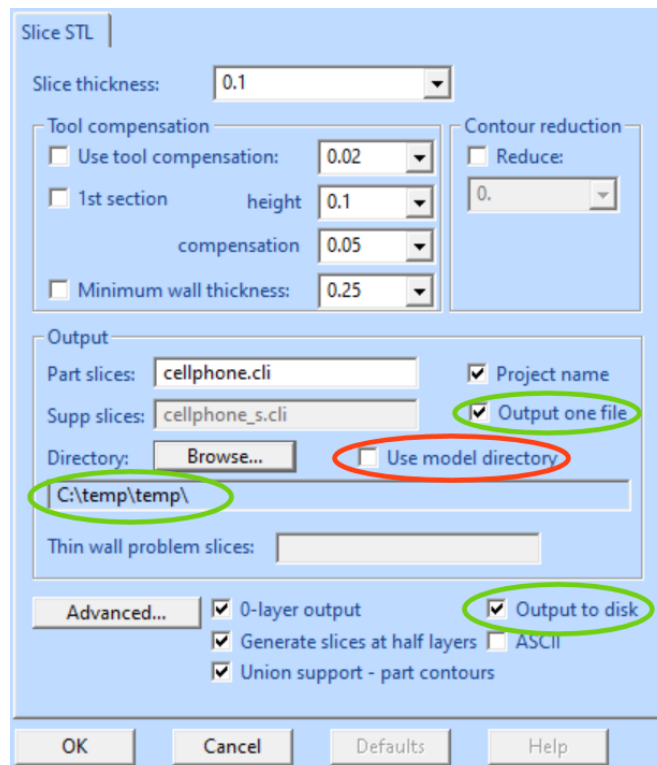

3Data Expert 16.0: Tutorial 4 - Generating Supports for AM



The *Output to one file* parameter will cause both the part and support slices to be stored in the same output file *cellphone.cli* (the *Supp slices* field is then greyed out). This also allows to use **Union support – part contours** option.

Press **OK** to start the slicing into the CLI contour file.

Previewing Slice data

We can now input the slice file into the 3Data Expert for inspection.

We will use the *File > Insert* command to input the slices into the Model Tree and keep the original 3D model.

Name	Size
 12-cellphones-3D-text.3de	27 755 KB
 cellphone.cli	40 206 KB

Press Open to insert the slice data in the Model Tree. After a while we can see the Slice preview tool open with the first slice level visible in the graphics area (hide the other shells to see the slice preview only):

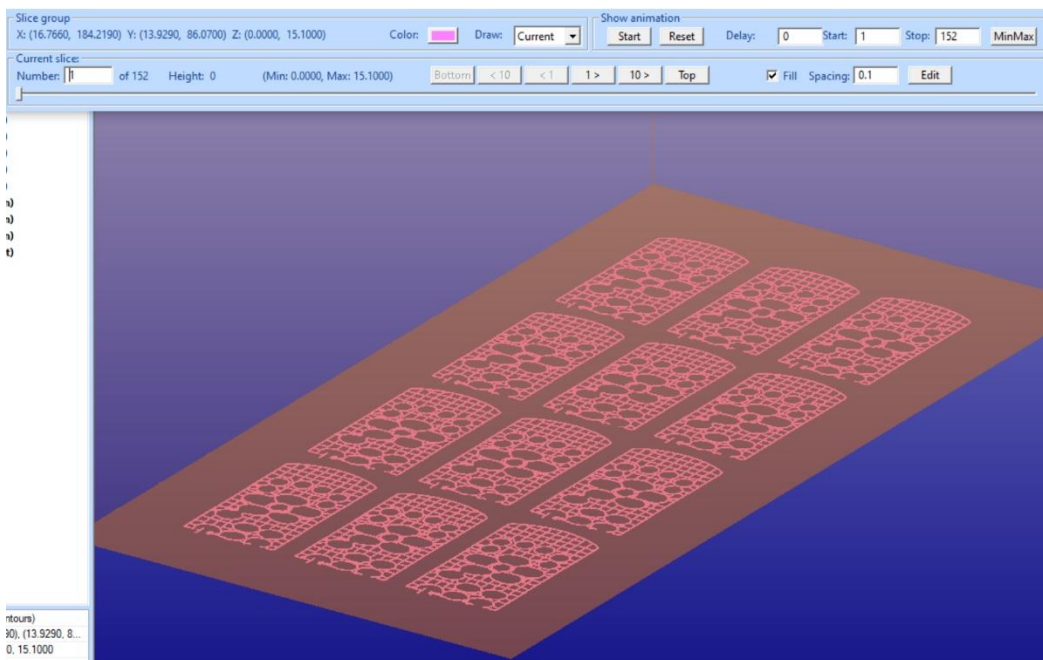

Normally it is best to look at the slices from positive Z axis direction: press the  icon to change the viewpoint (you may need to fit the slices by double clicking on the slice shell in the Model Tree):

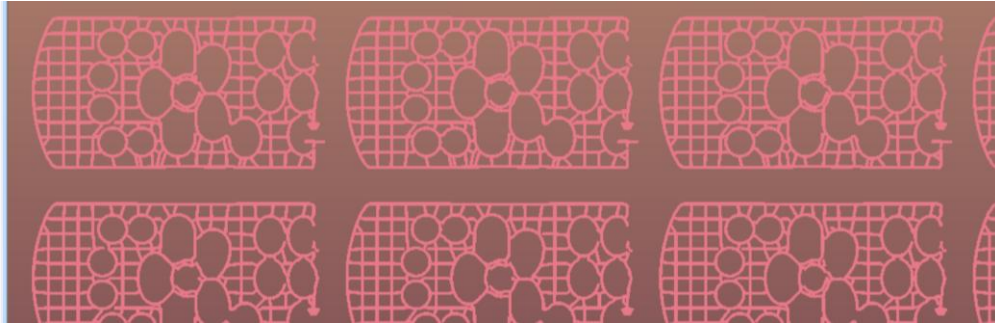

We can also turn off the platform display off with  icon.

Now you can start looking at the slices either individually with the slider in the *Current slice* group or start animation in the *Show animation* group to browse through all slices automatically.

To check the quality of the slicing it is possible to use *Fill* and *Spacing* parameters to simulate the hatching process with AM system software. You can set the density of the hatchign freely but remember that the smaller the spacing between the hatches the longer it takes to generate them.

Below is an example of a level 116 with Fill and 0.1 mm Spacing:

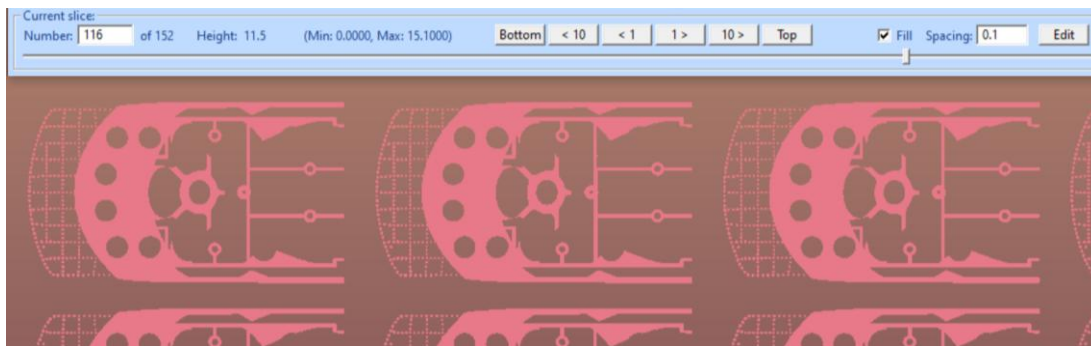

You can use all viewing commands like Zoom to look closer to any region on the slices. Even 3D viewing with the original model is possible. First select Model Tree root *All* to show the 3D model and then re-select the slice group. Slice colors can be changed to differ them from the part colors.

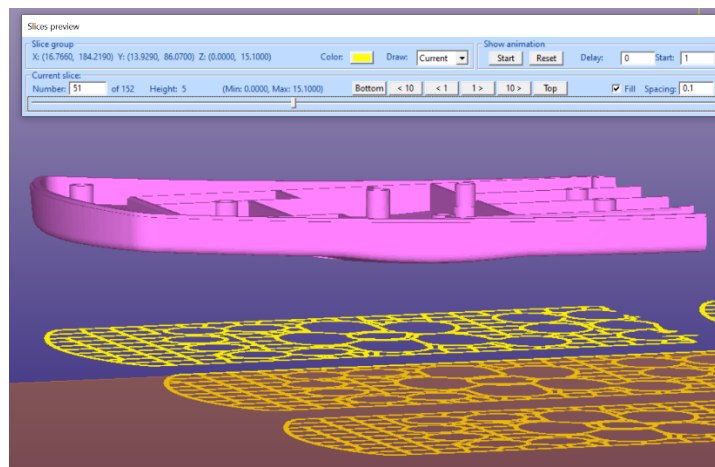

The Slice preview tool is turned on automatically when you select slices (cellphone (Contours)) shell from the Model Tree and turned off when something else is selected in the Model Tree. You can also press the  icon, select *View > Slice Preview* from the menu, or close the Slice Preview tools window on the right hand-corner Close icon. After that you can Copy/Paste/Delete etc. the slice shell.

Lesson 5 – Additional tools for support generation

There is a set of additional tools to aid the generation of optimal support for a part. These tools include Transformation commands, like Rotate and Move, as well as Center of Gravity calculation tools. For example, a part can be rotated so that the selected surface is facing exactly upwards for best surface finish or the Center of Gravity is set to the lowest point to minimize the bending forces to the part during the build.

Center of Gravity calculation

The *Dimensions > Center of Gravity* command is used to calculate the corresponding point in 3D. For the calculation the bounding box of the part is divided into 100x100x100 cells and the calculation is based on this subdivision.

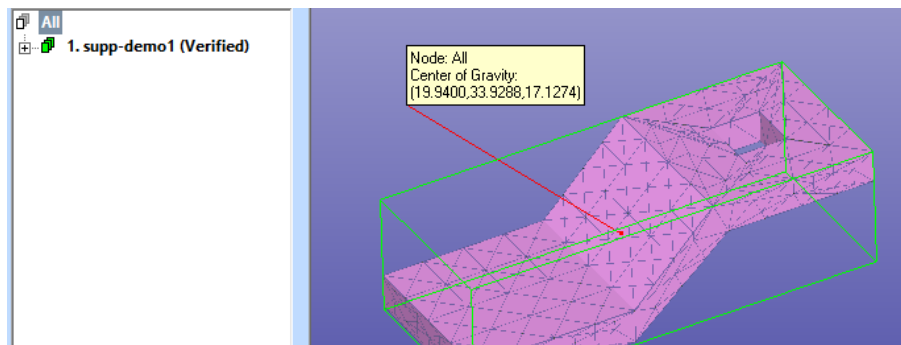

The *Center of Gravity* command can be run either on a single shell or root All to calculate common center of gravity for multiple shells. If multi-selection is used, the point is calculated to the first selection.

Lesson 6 – Connect Tool

The Connect Tool is used to add support struts between component details for added strength. Struts will prevent the model from warping during the AM or post-processing. This lesson is for the *Base* module only.

Connect Tool command

Connect Tool in the Modify Faceted menu will allow to add connecting struts and tree-like structures between component surfaces. The connecting struts will help to keep the shape of the part during support removal and post-processing. For this example we use file *1-cellphone.3de* file.

- **Input 1-cellphone.3de** from Tutorial/GeomFiles directory
- **Bypass Operation Mode etc.**

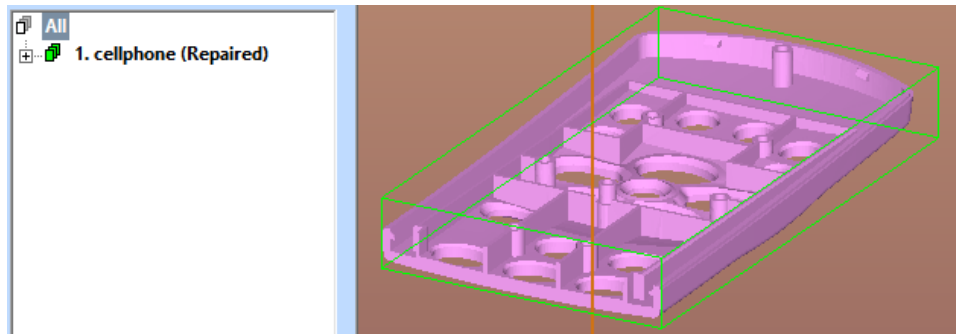

- **Select the cellphone (Repaired) shell** from the Model Tree and
- **start the *Modify Faceted > Connect Tool* command.**

The Connect Tool command toolbar appears:

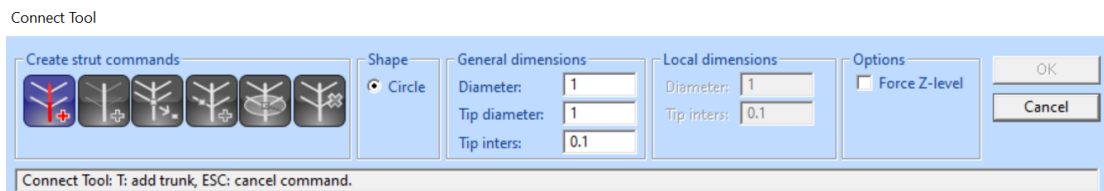

You must first set the *General Dimensions* of the connectors, overall *Diameter* 1.0 and *Tip diameter* 0.5. These will be stored to the connector tip and bend points during the connector creation.

When ready

- **push the active *Add strut trunk* button** .

You will go into strut point addition mode.

- Show the *strut start point* (red cross) and *end point* (blue cross) on the component walls with **LMB**. Then press **RMB**.

You can rotate the view during the point addition with the MMB (middle mouse button).

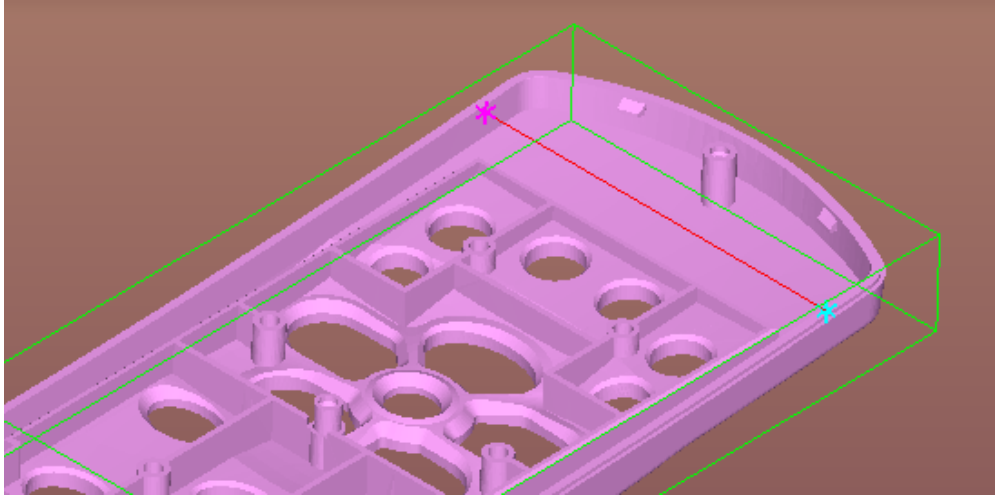

- After the **RMB** is pressed, the connection strut main trunk is ready:

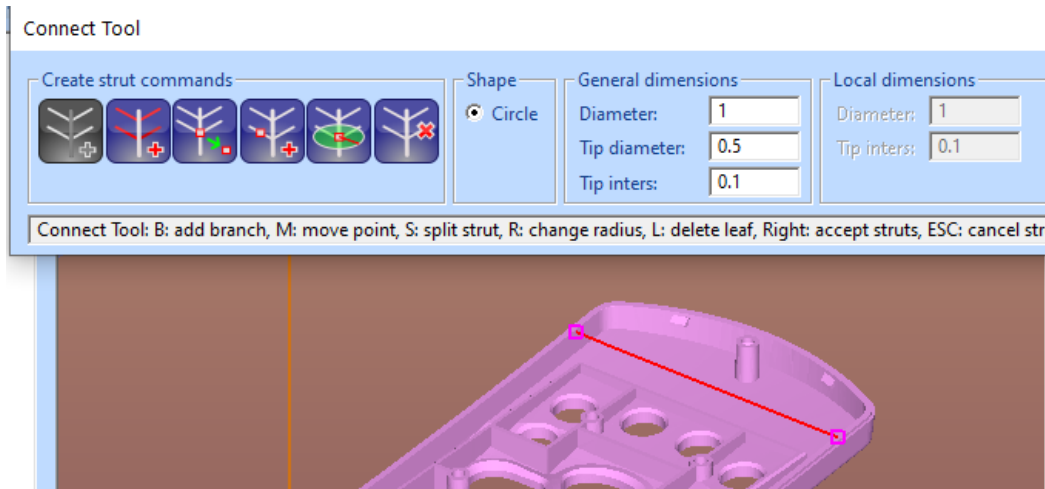

Now you can accept and generate the single strut by pressing RMB or OK button in the Toolbar. Or you can continue to add branches to the strut tree. We will do that.

- Now press the active **Add branches to strut**  button.
- Then show **first** point on the component feature with **LMB** (red cross) and the **second** point on the strut main trunk with **LMB**, as seen in the image below:

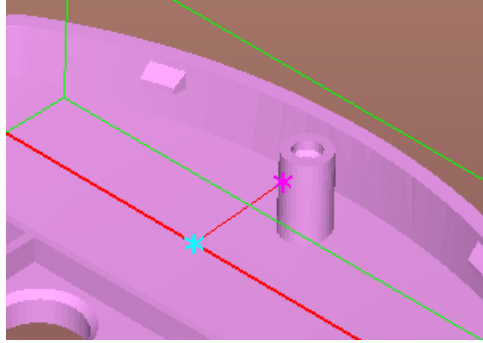

When ready

- **press *RMB*** to accept the branch. Note, you can *always cancel the last operation by pressing **ESC** button*.

You will see the branch added to the trunk structure.

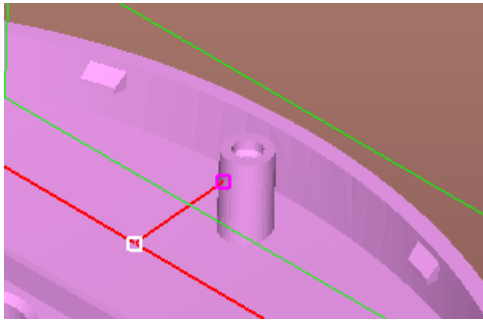

We will finally add two additional split points to separate the trunk end points from the trunk body. This is needed to have the tip diameter separated from the main trunk diameter more clearly (otherwise there would be continuous radius change from the back point in the middle towards the end points).

- **Press**  button to **Add point to split strut**. Show two points with the **LMB** as seen in the image below (blue crosses). When ready adding points **press *RMB***:

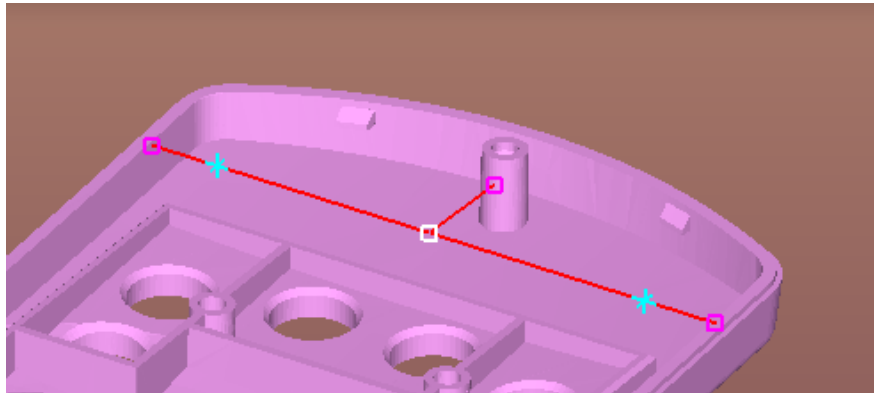

3Data Expert 16.0: Tutorial 4 - Generating Supports for AM

We are now ready creating the connect strut structure and will **press RMB** again or **OK** button in the toolbar to actually generate the triangle model for the struts.

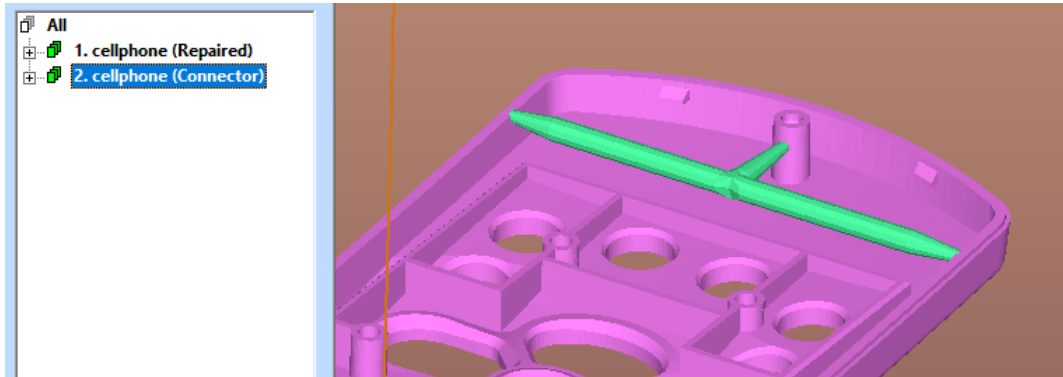

The connector strut is now stored in the Model Tree. It is a separate shell from the part component and there are different ways to use it with the cellphone part.

One normal way is to use Boolean commands, like *Modify Faceted > Multiple Join*, to combine the cellphone and the strut into one component. This way the connector will be produced with the part building parameters on the AM machine and would possibly have supports generated along the part support generation.

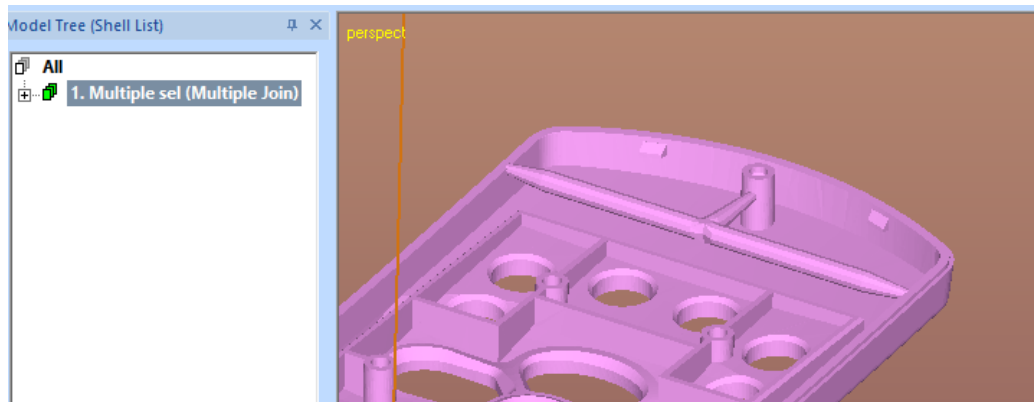

Another way is to mark the connector as being part of support structures (with *Print Preparation > Supports > Mark Supports* command, please see dialog below). This way the connector will be sliced and processed as part of the support structures.

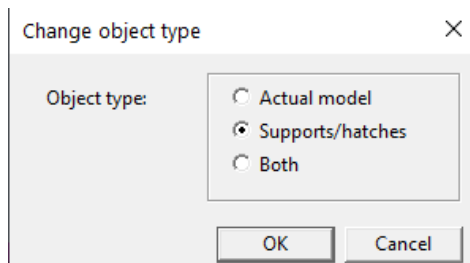

Lesson 7 – Sand Supports

The *Print Preparation > Supports > Sand Supports* command is used for generating sand support structures for sand-based AM systems. Sand supports form a supporting plate below the part to avoid breaking the part during clean-up and transportation to customer site. This lesson only applies to the 3Data Expert Base module.

Sand Support generation

In the sequel we will explain how to make a supporting plate to a thin cooling pipe geometry. We will use *cooling_pipe.stl* file as an example.

We must first open a suitable Print configuration for the sand supports.

Shift f8 --- pic --- import --- save

- **First, start with a fresh environment: *File > Close* (or *File > New*)**
- **If the *Tools Window* is not visible, press Shift+F8 to open it, then choose the *Print* tab**
- **Open the *Print configuration setup***
- For this example, changing the workspace size is sufficient: **choose the *Workspace* category, modify the maximum values to:**
 - Box X max = 1000**
 - Box Y max = 600**
 - Box Z max = 500**
- **Press *OK*** to accept the new workspace size. (It is not necessary to save the workspace, because it will only be used for this example.)

We can then proceed to model handling:

- **input the *cooling_pipe.stl* model from *Tutorials / GeomFiles* directory.**
- **run through the *Fix Model* and *Auto Repair* process.**
- **Go directly to the *Print* mode.**

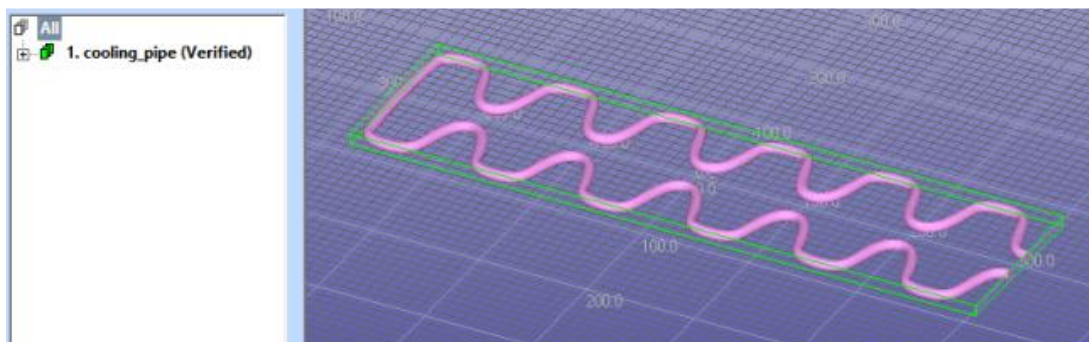

- **Move the cooling_pipe into a correct position** (positive space) with **Print Preparation > Move to Platform > Move Positive** command with the parameters below:

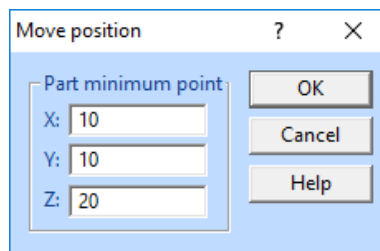

The part where the supports are to be generated must be selected before the command.

- **Select shell *cooling_pipe* from the Model Tree.**
- **Start support generation with the command *Print Preparation > Supports > Sand Support*.**

The dialog box for *Sand Support* parameters now opens. Each parameter includes a comprehensive text and image explanation.

First you will have to set the values for the support generation before executing the command. In the image below you can see the proper values to run the command for *cooling_pipe.stl* file. Especially, set the

- ***Sand support top level to 25 mm***, in the middle of the pipe part in Z direction,
- ***Support box offset to 10 mm and***
- ***Sand support base plate top level to 0 mm (this is no longer needed)***

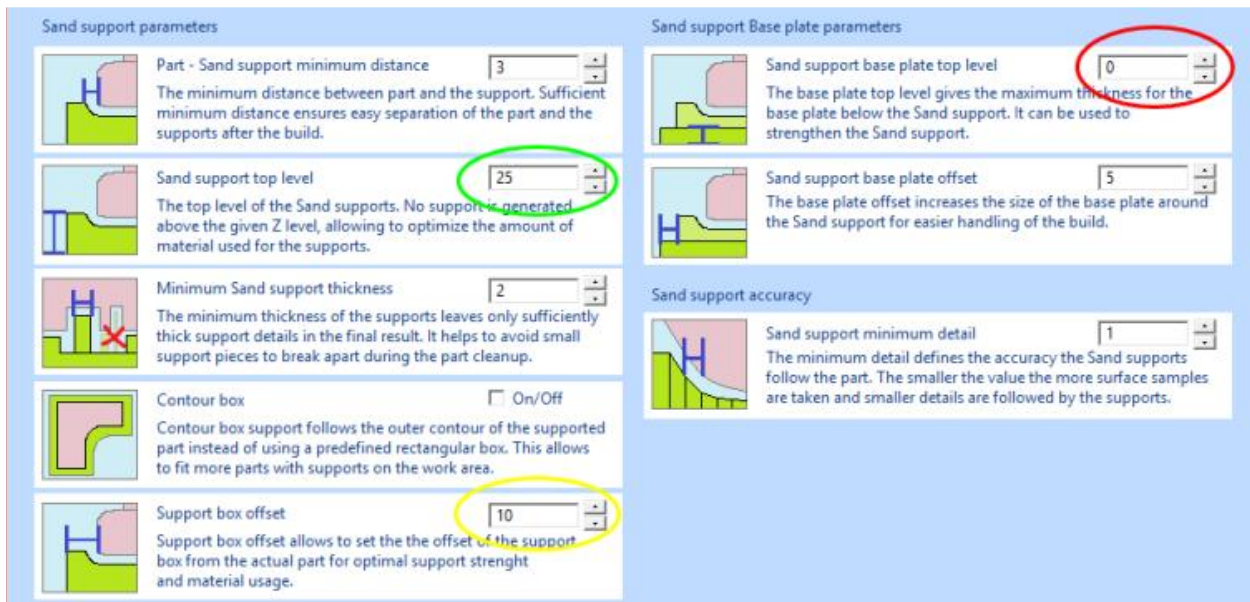

This set of parameters should get you started with the support generation. Anyhow, the exact values depend on the machine and the used resins. Testing, your own expertise and machine documentation will tell the correct values for each machine/material type.

- **Start the support generation by pressing *OK*.**

A percentage bar appears, and soon you will see the supports displayed on the screen.

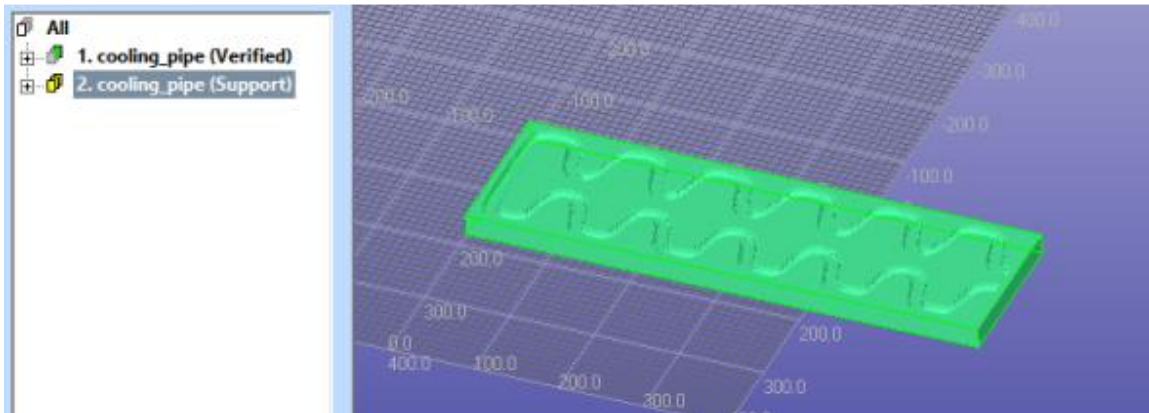

The part and the supports can now be selected with *multi-selection* and outputted into a single file for slicing with the machine vendor's software.

